

MELSEC-ST
Thermocouple Input Module
User's Manual

mitsubishi

MELSEC-ST
MELSEC-ST

MELSEC-**ST**

ST1TD2

● SAFETY PRECAUTIONS ●

(Read these precautions before using.)

When using this product, thoroughly read this manual and the associated manuals introduced in this manual. Also pay careful attention to safety and handle the product properly.

The precautions given in this manual are concerned with this product only. Refer to the user's manual of the network system for safety precautions of the network system.

In this manual, safety precautions are classified into two categories: "DANGER" and "CAUTION".



DANGER

Indicates that incorrect handling may cause hazardous conditions, resulting in death or severe injury.



CAUTION

Indicates that incorrect handling may cause hazardous conditions, resulting in minor or moderate injury or property damage.

Depending on circumstances, failure to observe  CAUTION level precautions may also lead to serious results.

Be sure to observe the instructions of both levels to ensure the safety.

Store this manual in a safe place for future reference and also pass it on to the end user.

[DESIGN PRECAUTIONS]

DANGER

- If a communication error occurs in the network, the error station (MELSEC-ST system) shows the following behavior:
All outputs turn OFF. (In the MELSEC-ST system, the output status at the time of error can be set to clear/hold/preset by user parameters of each slice module. As "clear" is set by default, the outputs turn OFF when an error occurs. In the case where the system operates safely with the output set to "hold" or "preset", change the parameter settings.)
Create an interlock circuit on the program so that the system operates safely based on the communication status information. Failure to do so may cause an accident due to faulty output or malfunction.
- Create an external fail safe circuit that will ensure the MELSEC-ST system operates safely, even when the external power supply or the system fails.
Accident may occur due to output error or malfunction.
 - (1) The status of output changes depending on the setting of various functions that control the output. Take sufficient caution when setting for those functions.
 - (2) Normal output may not be obtained due to malfunctions of output elements or the internal circuits. Configure a circuit to monitor signals whose operations may lead to a serious accident.

[DESIGN PRECAUTIONS]

CAUTION

- Make sure to initialize the network system after changing parameters of the MELSEC-ST system or the network system. If unchanged data remain in the network system, this may cause malfunctions.
- Do not install the control wires or communication cables together with the main circuit or power wires. Keep a distance of 100 mm (3.94 inch) or more between them. Not doing so could result in malfunctions due to noise.

[INSTALLATION PRECAUTIONS]

CAUTION

- Use the MELSEC-ST system in the general environment specified in the MELSEC-ST system users manual. Using this MELSEC-ST system in an environment outside the range of the general specifications could result in electric shock, fire, erroneous operation, and damage to or deterioration of the product.
- Mount the head module and base module(s) on the DIN rail securely (one by one) referring to the MELSEC-ST system users manual and then fix them with stoppers. Incorrect mounting may result in a fall of the module, short circuits or malfunctions.
- Secure the module with several stoppers when using it in an environment of frequent vibration. Tighten the screws of the stoppers within the specified torque range. Undertightening can cause a drop, short circuit or malfunction. Overtightening can cause a drop, short circuit or malfunction due to damage to the screw or module.
- Make sure to externally shut off all phases of the power supply for the whole system before mounting or removing a module. Failure to do so may damage the module.
 - (1) Online replacement of the power distribution module and/or the base module is not available. When replacing either of the modules, shut off all phases of the external power supply.
Failure to do so may result in damage to all devices of the MELSEC-ST system.
 - (2) The I/O modules and the intelligent function modules can be replaced online.
Since online replacement procedures differ depending on the module type, be sure to make replacement as instructed.
For details, refer to the chapter of online module change in this manual.
- Do not directly touch the module's conductive parts or electronic components. Doing so may cause malfunctions or failure of the module.
- Make sure to securely connect each cable connector. Failure to do so may cause malfunctions due to poor contact.

[INSTALLATION PRECAUTIONS]

CAUTION

- DIN rail must be conductive; make sure to ground it prior to use. Failure to do so may cause electric shocks or malfunctions. Undertightening can cause a short circuit or malfunction. Overtightening can cause a short circuit due to damage to the screw.

[WIRING PRECAUTIONS]

DANGER

- Completely turn off the external power supply when installing or placing wiring. Not completely turning off all power could result in electric shock or damage to the product.
- Always place the thermocouple or micro voltage signal cable at least 100mm(3.94inch) away from the main circuit cables and AC control lines.
Fully keep it away from high-voltage cables and circuits which include harmonics, such as an inverter's load circuit.
Not doing so will make the module more susceptible to noises, surges and inductions.

CAUTION

- Make sure to ground the control panel where the MELSEC-ST system is installed in the manner specified for the MELSEC-ST system. Failure to do so may cause electric shocks or malfunctions.
- Check the rated voltage and the terminal layout and wire the system correctly. Connecting an inappropriate power supply or incorrect wiring could result in fire or damage.
- Tighten the terminal screws within the specified torque range. If the terminal screws are loose, it could result in short circuits or erroneous operation. Overtightening may cause damages to the screws and/or the module, resulting in short circuits or malfunction.
- Prevent foreign matter such as chips or wiring debris from entering the module. Failure to do so may cause fires, damage, or erroneous operation.
- When connecting the communication and power supply cables to the module, always run them in conduits or clamp them. Not doing so can damage the module and cables by pulling a dangling cable accidentally or can cause a malfunction due to a cable connection fault.
- When disconnecting the communication and power supply cables from the module, do not hold and pull the cable part. Disconnect the cables after loosening the screws in the portions connected to the module. Pulling the cables connected to the module can damage the module and cables or can cause a malfunction due to a cable connection fault.

[STARTUP AND MAINTENANCE PRECAUTIONS]

DANGER

- Do not touch the terminals while power is on.
Doing so could cause shock or erroneous operation.
- Make sure to shut off all phases of the external power supply for the system before cleaning the module or tightening screws.
Not doing so can cause the module to fail or malfunction.

CAUTION

- Do not disassemble or modify the modules.
Doing so could cause failure, erroneous operation, injury, or fire.
- Do not drop or give a strong impact to the module since its case is made of resin. Doing so can damage the module.
- Make sure to shut off all phases of the external power supply for the system before mounting/removing the module onto/from the control panel. Not doing so can cause the module to fail or malfunction.
- Before handling the module, make sure to touch a grounded metal object to discharge the static electricity from the human body.
Failure to do so may cause a failure or malfunctions of the module.
- When using any radio communication device such as a cellular phone, keep a distance of at least 25cm (9.85 inch) away from the MELSEC-ST system.
Not doing so can cause a malfunction.

[DISPOSAL PRECAUTIONS]

CAUTION

- When disposing of this product, treat it as industrial waste.

REVISIONS

* The manual number is given on the bottom left of the back cover.

Print Date	* Manual Number	Revision
Mar., 2005	SH(NA)-080539ENG-A	First edition
Jun., 2006	SH(NA)-080539ENG-B	<div style="border: 1px solid black; display: inline-block; padding: 2px;">Correction</div> Appendix 5

Japanese Manual Version SH-080538-B

This manual confers no industrial property rights or any rights of any other kind, nor does it confer any patent licenses. Mitsubishi Electric Corporation cannot be held responsible for any problems involving industrial property rights which may occur as a result of using the contents noted in this manual.

© 2005 MITSUBISHI ELECTRIC CORPORATION

INTRODUCTION

Thank you for choosing the ST1TD2 type MELSEC-ST thermocouple input module.
Before using the module, please read this manual carefully to fully understand the functions and performance of the ST1TD2 type MELSEC-ST thermocouple input module and use it correctly.

CONTENTS

SAFETY PRECAUTIONS.....	A- 1
REVISIONS.....	A- 5
INTRODUCTION.....	A- 6
About Manuals	A- 9
Compliance with the EMC Directive and the Low Voltage Directive	A- 9
How to Read Manual.....	A-10
About the Generic Terms and Abbreviations	A-12
Term definition.....	A-13
1 OVERVIEW	1- 1 to 1- 2
1.1 Features	1- 1
2 SYSTEM CONFIGURATION	2- 1 to 2- 2
2.1 Overall Configuration	2- 1
2.2 Applicable System.....	2- 2
2.2.1 Applicable head module.....	2- 2
2.2.2 Applicable base module.....	2- 2
2.2.3 Applicable coding element.....	2- 2
2.2.4 Applicable software package	2- 2
2.2.5 Applicable GSD file	2- 2
2.3 Precautions for System Configuration.....	2- 2
3 SPECIFICATIONS	3- 1 to 3-25
3.1 Performance Specifications.....	3- 1
3.1.1 Micro voltage I/O conversion characteristic.....	3- 4
3.1.2 Conversion speed	3- 5
3.1.3 Intelligent function module processing time	3- 5
3.2 Function.....	3- 6
3.2.1 Function list.....	3- 6
3.2.2 Temperature conversion function	3- 9
3.2.3 Micro voltage conversion function	3-10
3.2.4 Temperature/micro voltage conversion system	3-11
3.2.5 Disconnection detection function.....	3-13
3.2.6 Alarm output function	3-14
3.2.7 Cold junction temperature compensation setting.....	3-16
3.2.8 Sensor compensation function	3-17
3.3 I/O Data	3-18
3.3.1 Bit input area	3-19
3.3.2 Error information area	3-21
3.3.3 Module status area.....	3-21
3.3.4 Word input area.....	3-21
3.3.5 Bit output area	3-22

3.3.6 Error clear area.....	3-23
3.3.7 Word output area.....	3-23
3.4 Memory and Parameters	3-24
3.4.1 Memory.....	3-24
3.4.2 Parameters.....	3-25

4 SETUP AND PROCEDURES BEFORE OPERATION	4- 1 to 4-25
------------------------------------------------	---------------------

4.1 Handling Precautions.....	4- 1
4.2 Setup and Procedure before Operation	4- 2
4.3 Part Names	4- 3
4.3.1 Status confirmation by LED	4- 4
4.4 Wiring.....	4- 5
4.4.1 Wiring precautions.....	4- 5
4.4.2 External wiring.....	4- 6
4.5 Offset/gain Setting.....	4- 8
4.5.1 Offset/gain settings procedure.....	4-10

5 GX Configurator-ST	5- 1 to 5-12
-----------------------------	---------------------

5.1 GX Configurator-ST Functions	5- 1
5.2 Project Creation	5- 2
5.3 Parameter Setting	5- 3
5.4 Input/Output Monitor	5- 7
5.5 Forced Output Test.....	5- 8
5.6 Offset/Gain Setting.....	5-10

6 PROGRAMMING	6- 1 to 6-27
----------------------	---------------------

6.1 Programming Procedure.....	6- 2
6.2 When QJ71PB92D is Used as Master Station	6- 4
6.2.1 Program example available when using auto refresh in QJ71PB92D	6-12
6.3 When Using AJ71PB92D/A1SJ71PB92D as Master Station.....	6-18

7 ONLINE MODULE CHANGE	7- 1 to 7-11
-------------------------------	---------------------

7.1 Precautions for Online Module Change	7- 1
7.2 Preparations for Online Module Change.....	7- 3
7.3 Disconnecting/Connecting the External Device for Online Module Change	7- 3
7.4 Online Module Change Procedure.....	7- 4
7.4.1 When parameter setting or offset/gain setting is performed using GX Configurator-ST during online module change.....	7- 4

8 COMMAND	8- 1 to 8-47
------------------	---------------------

8.1 Command List.....	8- 1
8.2 Common Command.....	8- 3
8.2.1 Operating status read request (Command No.: 0100H).....	8- 3
8.2.2 Error code read request (Command No.: 0101H)	8- 5
8.3 ST1TD2 Parameter Setting Read Command	8- 7
8.3.1 Conversion enable/disable setting read (Command No.: 1300H).....	8- 7
8.3.2 Conversion completion channel read (Command No.: 1301H)	8- 9
8.3.3 Operation condition set value read (Command No.: 1302H)	8-11

8.3.4 CH□ average time/average number of times set value read (Command No.: 1304H).....	8-13
8.3.5 CH□ upper upper/upper lower limit set value read (Command No.: 1308H, 130AH).....	8-15
8.3.6 CH□ lower upper/lower lower limit set value read (Command No.: 1309H, 130BH).....	8-17
8.3.7 User parameter set value read (Command No.: 1318H).....	8-19
8.3.8 Sensor compensation value read (Command No.: 131AH).....	8-22
8.4 ST1TD2 Parameter Setting Write Command	8-24
8.4.1 Conversion enable/disable setting write (Command No.: 2300H)	8-24
8.4.2 Operation condition set value write (Command No.: 2302H).....	8-26
8.4.3 CH□ average time/average number of times set value write (Command No.: 2304H)	8-28
8.4.4 CH□ upper upper/upper lower limit set value write (Command No.: 2308H, 230AH)	8-30
8.4.5 CH□ lower upper/ lower lower limit set value write (Command No.: 2309H, 230BH)	8-32
8.4.6 Sensor compensation value write (Command No.: 231AH).....	8-34
8.5 ST1TD2 Control Command	8-36
8.5.1 Parameter setting ROM read (Command No.: 3300H)	8-36
8.5.2 Parameter setting ROM write (Command No.: 3301H).....	8-37
8.5.3 Operation mode setting (Command No.: 3302H).....	8-39
8.5.4 Offset channel specification (Command No.: 3303H)	8-41
8.5.5 Gain channel specification (Command No.: 3304H)	8-43
8.5.6 User range write (Command No.: 3305H)	8-45
8.6 Values Stored into Command Execution Result.....	8-46

9 TROUBLESHOOTING	9- 1 to 9- 6
--------------------------	---------------------

9.1 Error Code List	9- 1
9.2 Troubleshooting	9- 4
9.2.1 When the RUN LED is flashing or turned off.....	9- 4
9.2.2 When the RUN LED and the ERR. LED turned on.....	9- 4
9.2.3 When line break down has been detected	9- 5
9.2.4 Measured temperature value/micro voltage conversion cannot be read	9- 5
9.2.5 Measured temperature value is abnormal.....	9- 6
9.2.6 Micro voltage conversion value is abnormal	9- 6

APPENDIX	App- 1 to App-35
-----------------	-------------------------

Appendix 1 Accessories.....	App- 1
Appendix 2 Usual Operation Limit and Superheated Operation Limits	App- 2
Appendix 3 Allowable Temperature Differences.....	App- 3
Appendix 4 Thermal Electromotive Force Chart.....	App- 4
Appendix 4.1 Standard Thermal Electromotive Force of K	App- 5
Appendix 4.2 Standard Thermal Electromotive Force of E	App- 9
Appendix 4.3 Standard Thermal Electromotive Force of J	App-12
Appendix 4.4 Standard Thermal Electromotive Force of T.....	App-16
Appendix 4.5 Standard Thermal Electromotive Force of B	App-18
Appendix 4.6 Standard Thermal Electromotive Force of R	App-22
Appendix 4.7 Standard Thermal Electromotive Force of S	App-26
Appendix 4.8 Standard Thermal Electromotive Force of N	App-30
Appendix 5 External Dimensions.....	App-34

INDEX	Index- 1 to Index- 2
--------------	-----------------------------

About Manuals

The following manuals are related to this product.
Referring to this list, please request the necessary manuals.

Relevant Manuals

Manual Name	Manual Number (Model Code)
MELSEC-ST System User's Manual Explains the system configuration of the MELSEC-ST system and the performance specifications, functions, handling, wiring and troubleshooting of the power distribution modules, base modules and I/O modules. (Sold separately)	SH-080456ENG (13JR72)
MELSEC-ST PRFIBUS-DP Head Module User's Manual Explains the system configuration, specifications, functions, handling, wiring and troubleshooting of the ST1H-PB. (Sold separately)	SH-080436ENG (13JR68)
GX Configurator-ST Version 1 Operating Manual Explains how to operate GX Configurator-ST, how to set the intelligent function module parameters, and how to monitor the MELSEC-ST system. (Sold separately)	SH-080439ENG (13JU47)

Compliance with the EMC Directive and the Low Voltage Directive

When incorporating the Mitsubishi MELSEC-ST system that is compliant with the EMC directive and the low voltage directive into other machine or equipment and making it comply with the EMC directive and the low voltage directive, refer to "EMC Directive and Low Voltage Directive" of the MELSEC-ST System User's Manual. The CE logo is printed on the rating plate of the EMC Directive and the Low Voltage Directive.

By making this product conform to the EMC directive and low voltage instruction, it is not necessary to make those steps individually.

How to Read Manual

This manual explains each area for input data and output data using the following symbols.

(1) Data symbol

<Example: Cr Command result area>

Cr. 0 (7-0)

Range

In the case of 1-word (16 bit) data, this shows the corresponding range.

(0) : Shows 0 bit position

(7-0): Shows 0-7 bit range

Detail data No.

Abbreviated data symbol

For details of detail data No. and abbreviated data symbol, refer to (2) and (3)

(2) Input data

Data symbol	Area	Unit	Detail data No. notation
Br	Br.00 to Br.FF	Bit Input Area	Hexadecimal
Er	Er.00 to Er.FF	Error Information Area	Hexadecimal
Mr	Mr.0 to Mr.127	Module Status Area	Decimal
Cr	*1	Command Result Area	Decimal
Wr	Wr.00 to Wr.33	Word Input Area	Hexadecimal

*1: The following shows the data symbols and the corresponding detail areas within the command result area.

Data symbol	Area
Cr.0	Cr.0 (15-8) Command Execution Area
	Cr.0 (7-0) Start Slice No. of Execution Target
Cr.1	Executed Command No.
Cr.2	Response Data 1
Cr.3	Response Data 2

(3) Output data

Data symbol		Area	Unit	Detail data No. notation
<u>Bw</u>	<u>Bw.00</u> to <u>Bw.FF</u>	Bit Output Area	1 bit/1 symbol	Hexadecimal
<u>Ew</u>	<u>Ew.00</u> to <u>Ew.FF</u>	Error Clear Area	1 bit/1 symbol	Hexadecimal
<u>Sw</u>	<u>Sw.0</u> to <u>Sw.7</u>	System Area	1 word/1 symbol	Decimal
<u>Cw</u>	*1	Command Execution Area	1 word/1 symbol	Decimal
<u>Ww</u>	<u>Ww.00</u> to <u>Ww.33</u>	Word Output Area	1 word/1 symbol	Hexadecimal

*1: The following shows the data symbols and the corresponding detail areas within the command execution area.

Data symbol	Area
<u>Cw.0</u>	Start Slice No. of Execution Target
<u>Cw.1</u>	Command No. to be Executed
<u>Cw.2</u>	Argument 1
<u>Cw.3</u>	Argument 2

About the Generic Terms and Abbreviations

This manual uses the following generic terms and abbreviations to describe the ST1TD2, unless otherwise specified.

Generic Term/Abbreviation	Description
ST1TD2	Abbreviation for ST1TD2 type MELSEC-ST thermocouple input module.
Head module	ST1H-PB, MELSEC-ST PROFIBUS-DP compatible head module.
PROFIBUS-DP	PROFIBUS-DP network.
Bus refreshing module	Module that distributes the external SYS. power supply and external AUX. power supply among the head module and slice modules.
Power feeding module	Module that distributes external AUX. power supply among slice modules.
Power distribution module	Generic term for bus refreshing module and Power feeding module.
Base module	Module that transfers data/connects between the head module and slice modules, and between slice modules and external devices.
Input module	Module that handles input data in bit units.
Output module	Module that handles output data in bit units.
Intelligent function module	Module that handles input/output data in word units.
I/O module	Generic term for input module and output module.
Slice module	Module that can be mounted to the base module: power distribution module, I/O module and intelligent function module.
MELSEC-ST system	System that consists of head module, slice modules, end plates and end brackets.
GX Configurator-ST	SWnD5C-STPB-E type products. (n: 1 or later)
Configuration software	Software used to set slave parameters for head module and slice modules.(e.g., GX Configurator-DP)
User parameter	Generic term for setting items (Input type setting, Offset/gain value selection, Cold junction temperature compensation setting) set by the configuration software of the master station.
Command parameter	Generic term for setting items (Conversion enable/disable setting, Sampling process/averaging process specification, Time/count averaging specification, Average time/average number of times setting, Alarm output setting, Upper upper limit value/Upper lower limit value/Lower upper limit value/Lower lower limit value setting, Sensor compensation value setting) set by commands. They can also be set by GX Configurator-ST.
Parameter	Generic term for user parameters and command parameters.

Term definition

The following explains the meanings and definitions of the terms used in this manual.

Term	Definition
Master station	Class 1 master station that communicates I/O data with slave stations.
Slave station	Device that communicates I/O data with the master station.
Repeater	Device that connects PROFIBUS-DP segments.
Bus terminator	Terminator that is connected to both ends of each PROFIBUS-DP segment
FDL address	Address assigned to the master station or slave station.
GSD file	The electronic file that includes description of the slave station parameters. The file is used to set parameters at the master station.
Input data	Data sent from the head module to the master station. The data consists of the following areas. <ul style="list-style-type: none"> ▪ Br Bit Input Area ▪ Information Area <ul style="list-style-type: none"> Er Error Information Area Mr Module Status Area Cr Command Result Area ▪ Wr Word Input Area
Output data	Data that the head module receives from the master station. The data consists of the following areas. <ul style="list-style-type: none"> ▪ Bw Bit Output Area ▪ Request Area <ul style="list-style-type: none"> Ew Error Clear Area Sw System Area Cw Command Execution Area ▪ Ww Word Output Area
I/O data	Data (input data, output data) transferred between the head module and the master station.
Br.n bit input	Bit input data of each module.
Bw.n bit output	Bit output data of each module
Wr.n word input	Word (16-bit) input data of an intelligent function module. In the case of analog input module, a digital output data value is stored.
Ww.n word output	Word (16-bit) output data of an intelligent function module. In the case of analog output module, a digital setting data value is stored.
Information area	Bit/Word input data for checking each module status and command execution results.
Request area	Bit/Word output data for requesting each module to clear errors/to execute commands.
Number of occupied I/O points	The area, that is equivalent to the occupied I/O points, is occupied in Br bit input area/ Bw bit output area.
Slice No.	No. assigned to every 2 occupied I/O points of each module. This numbering starts by assigning "0" to the head module and then proceeds in ascending order. (The maximum is 127). The No. is used for specifying the execution target.
Command	Generic term for requests made by the master station in order to read each module's operating status and to set and control intelligent function module operation.

1 OVERVIEW

1

This User's Manual provides the specifications, handling instructions, programming methods, etc. for the ST1TD2 type MELSEC-ST thermocouple input module (hereinafter referred to as the ST1TD2).

This manual includes descriptions of only the ST1TD2.

For information on the MELSEC-ST system, refer to the MELSEC-ST System User's Manual.

ST1TD2 is a module converting the external thermocouple input value into measured temperature value of signed 16-bit binary data, and the micro voltage signal into signed 16-bit binary data.

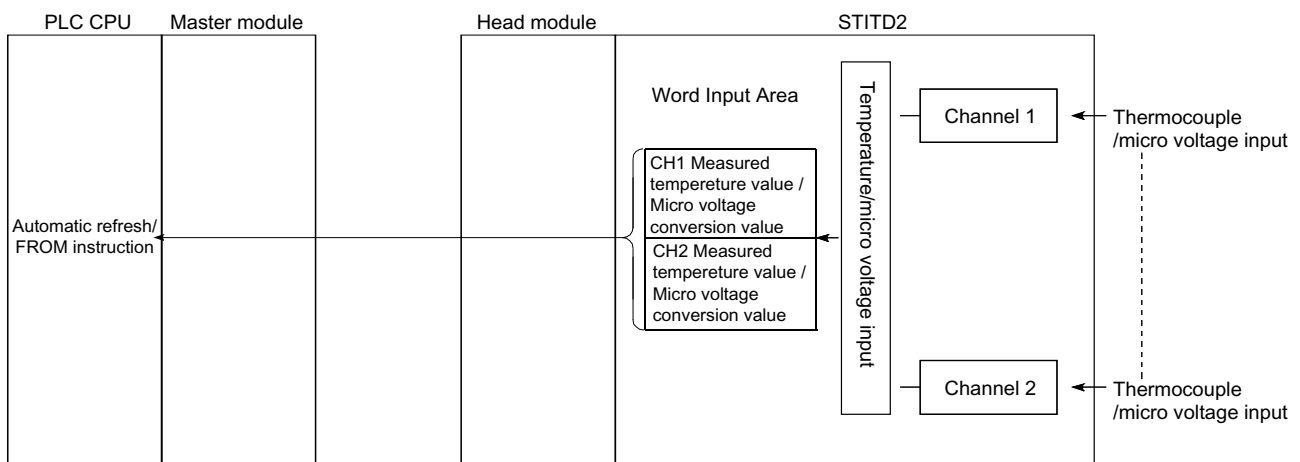

1.1 Features

- (1) One ST1TD2 enables 2-channel temperature measurement/micro voltage conversion.
By using ST1TD2, the temperature measurement or micro voltage conversion can be performed for 2 channels.
- (2) Up to 26 modules can be mounted
For one head module, up to 26 ST1TD2 modules (52 channels) can be mounted.
- (3) Using thermocouple complying with IEC/DIN/JIS
Eight kinds of thermocouples (K,E,J,T,B,R,S,N) complying with IEC/DIN/JIS can be used.
Using configuration software in the master station and/or GX Configurator-ST, you can choose a desirable thermocouple type for each channel.
- (4) Disconnection detection
The disconnection of a thermocouple, compensation lead wire or micro voltage signal cable can be detected on each channel.
- (5) Selection of sampling/time averaging/count averaging processing
As a conversion processing method, you can choose sampling processing, time averaging processing or count averaging processing on each channel.

(6) Pt1000 temperature-measuring resistor for cold junction temperature compensation

Cold junction temperature compensation will be performed automatically since a Pt1000 temperature-measuring resistor is built in the dedicated base module.

(7) Pt1000 cold junction temperature compensation enable/disable setting

Disabling cold junction temperature compensation with Pt1000 temperature-measuring resistor enables cold junction temperature compensation to be made outside the module.

If the cold junction temperature compensation accuracy of Pt1000 temperature measuring resistor is not to be ignored as an error, the accuracy can be improved by a high-precision ice bath applied externally. (Ambient air temperature $25\pm 5^{\circ}\text{C}$: $\pm 1.5^{\circ}\text{C}$, Ambient air temperature 0 to 55°C : $\pm 2.5^{\circ}\text{C}$)

(8) One-point compensation is available using the sensor compensation function

The sensor compensation function allows 1-point compensation for each channel.

When an error is identified between the "actual temperature/voltage" and the "measured temperature/voltage", it can be compensated easily by setting the sensor compensation value.

(9) Two-point compensation is available using the offset/gain setting

The offset/gain setting allows 2-point compensated for each channel.

You can choose the user range setting (setup corrected by users) or factory default (default setting) for the offset/gain setting.

(10) Alarm output

If the temperature detected is outside the preset measurement range, an alarm can be output on each channel.

(11) Online module change

The module can be changed without the system being stopped.

(12) Easy settings using GX Configurator-ST

The optional software package (GX Configurator-ST) is available.

GX Configurator-ST is not necessarily required for the system.

However, we recommend using GX Configurator-ST, as it enables on-screen parameter setting and offset/gain setting, which reduces programming steps and makes the setting/operating status check easier.

2 SYSTEM CONFIGURATION

This chapter describes the system configuration for use of the ST1TD2.

2.1 Overall Configuration

The overall configuration for use of the ST1TD2 is shown below.

<The system using QJ71PB92D>

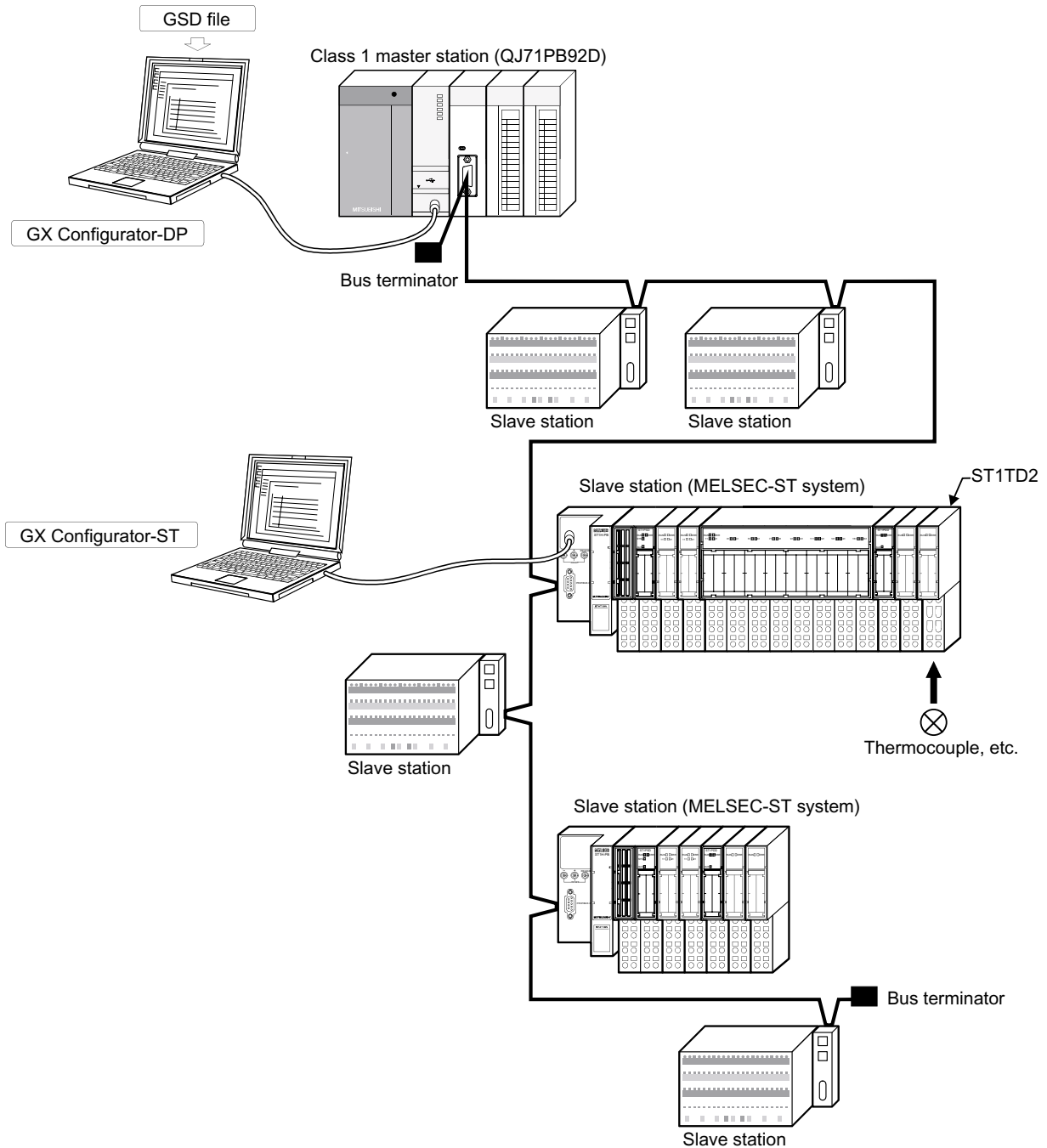

2.2 Applicable System

This section explains the applicable system.

2.2.1 Applicable head module

The head module applicable to the ST1TD2 is indicated below.

Product name	Model name
MELSECT-ST PROFIBUS-DP Head Module	ST1H-PB

2

2.2.2 Applicable base module

The base modules applicable to the ST1TD2 are indicated below.

Type	Model name
Spring Clamp Type	ST1B-S4TD2
Screw Clamp Type	ST1B-E4TD2

2.2.3 Applicable coding element

The coding elements applicable to the ST1TD2 are indicated below.

The coding element is fitted before shipment.

It is also available separately in case it is lost.

Description	Model name
ST1TD2 coding element	ST1A-CKY-16

2.2.4 Applicable software package

The software package applicable to the ST1TD2 is indicated below.

Model name	Product name	Compatible software version
SW1D5C-STPB-E	GX Configurator-ST	Version 1.02C or later

2.2.5 Applicable GSD file

The GSD file applicable to the ST1TD2 is indicated below.

Description	Compatible version*
GSD file applicable to ST1TD2	rel. 1.01

* The GSD file name and version are displayed in the GSD file registration list of the configuration software on the master station.

Check that the version is rel. 1.01 or later.

2.3 Precautions for System Configuration

For precautions for ST1TD2 system configuration, refer to Section 3.4 "Precautions for System Configuration" in MELSEC-ST system user's manual.

3 SPECIFICATIONS

This chapter provides the specifications of the ST1TD2.
 For the general specifications of the ST1TD2, refer to the MELSEC-ST System User's Manual.

3.1 Performance Specifications

This section indicates the performance specifications of the ST1TD2.

(1) Performance specifications list

Item		Specifications													
Number of analog input points		2 channels / 1 module													
Output	Temperature conversion value	16-bit signed binary (-2700 to 18200: Value to the first decimal place × 10 times)													
	Micro voltage conversion value	16-bit signed binary (-20000 to 20000)													
Standard with which thermocouple conforms		IEC584-1(1977), IEC584-2(1982), JIS C1602-1995													
Usable thermocouples and measured temperature range accuracies		Refer to Section 3.1 (2)													
Cold junction temperature compensation accuracy		Ambient air temperature 25±5°C : 1.5°C Ambient air temperature 0 to 55°C : ±2.5°C													
Thermocouple input accuracy		Based on calculation expression marked * 1													
Micro voltage input range		-80mV to 80mV (input resistance 1MΩ or more)													
Micro voltage input accuracy		Ambient air temperature 25±5°C : ±0.16mV Ambient air temperature 0 to 55°C : ±0.32mV													
Resolution	Thermocouple input	K,T:0.3°C E:0.2°C J:0.1°C B:0.7°C R,S:0.8°C N:0.4°C													
	Micro voltage input	4μV													
Conversion speed		Cold junction temperature compensation setting: Not set: 30ms/channel, Set: 60ms/channel													
Wire break detection		Yes (Channel independent) * 2													
Absolute maximum input		±4V													
ROM write count		ROM write count by user range write or parameter setting: Up to 10,000 times													
Number of occupied I/O points		4 points for each of input and output													
Number of occupied slices		2													
Information amount	Input data	[Br.n] : Number of occupancy 4, [Er.n] : Number of occupancy 4, [Mr.n] : Number of occupancy 2, [Wr.n] : Number of occupancy 2													
	Output data	[Bw.n] : Number of occupancy 4, [Ew.n] : Number of occupancy 4, [Ww.n] : Number of occupancy 2													
Isolation	<table border="1"> <thead> <tr> <th>Specific isolated area</th> <th>Isolation method</th> <th>Dielectric withstand</th> <th>Insulation resistance</th> </tr> </thead> <tbody> <tr> <td>Between thermocouple input/micro voltage input channels and internal bus</td> <td>Photo coupler insulation</td> <td>560V AC rms/3 cycles (elevation 2000m)</td> <td>500V DC 10MΩ or more</td> </tr> <tr> <td>Between thermocouple input/micro voltage input channels</td> <td>No insulation</td> <td>—</td> <td>—</td> </tr> </tbody> </table>			Specific isolated area	Isolation method	Dielectric withstand	Insulation resistance	Between thermocouple input/micro voltage input channels and internal bus	Photo coupler insulation	560V AC rms/3 cycles (elevation 2000m)	500V DC 10MΩ or more	Between thermocouple input/micro voltage input channels	No insulation	—	—
	Specific isolated area	Isolation method	Dielectric withstand	Insulation resistance											
	Between thermocouple input/micro voltage input channels and internal bus	Photo coupler insulation	560V AC rms/3 cycles (elevation 2000m)	500V DC 10MΩ or more											
Between thermocouple input/micro voltage input channels	No insulation	—	—												
Applicable base module	Spring clamp type: ST1B-S4TD2 Screw clamp type: ST1B-E4TD2														
Applicable coding element	ST1A-CKY-16(dusty gray)														
External AUX. power supply	24V DC (+20/-15%, ripple ratio within 5%)														
	24V DC current: 0.030A														
5V DC internal current consumption	0.080 A														

Item	Specifications
External dimensions	77.6 (3.06in.) (H) × 12.6 (0.50in.) (w) × 55.4 (2.18in.) (D) [mm]
Weight	0.04 kg

* 1: Calculate the accuracy in the following method.

(Accuracy) = (conversion accuracy) + (temperature characteristic) × (operating ambient temperature variation) + (cold junction temperature compensation accuracy)

An operating ambient temperature variation indicates a value of deviation from the operating ambient temperature range of 25±5°C.

Example: When the thermocouple used is B (Refer to Section 3.1 (2), the operating ambient temperature is 35°C, the measured temperature is 1000°C, and the cold junction temperature compensation setting is set, the accuracy is: (±3.5°C) + (±0.35°C) × (35°C - 30°C) + (±2.5°C) = ±7.75°C

* 2: At wire break detection, the measured temperature value/micro voltage conversion value right before wire break occurrence is held.

(2) Usable Thermocouples and Measured Temperature Range Accuracies

The usable thermocouples and measured temperature range accuracies will be explained.

Usable Thermocouple Type	Measured Temperature Range * 1	Conversion Accuracy (At operating ambient temperature 25±5°C)	Temperature Characteristic (Per operating ambient temperature variation of 1°C)	Max. Temperature Error at Ambient Temperature 55°C * 4
K	-270 to -200°C* 3		—	
	-200 to 1200°C* 2	±2.0°C	±0.2°C	±7.0°C
	1200 to 1372°C* 3		—	
E	-270 to -200°C* 3		—	
	-200 to 900°C* 2	±1.5°C	±0.16°C	±5.5°C
	900 to 1000°C* 3		—	
J	-210 to -40°C* 3		—	
	-40 to 750°C* 2	±1.0°C	±0.14°C	±4.5°C
	750 to 1200°C* 3		—	
T	-270 to -200°C* 3		—	
	-200 to 350°C* 2	±2.0°C	±0.14°C	±5.5°C
	350 to 400°C* 3		—	
B	0 to 600°C* 3		—	
	600 to 1700°C* 2	±3.5°C	±0.35°C	±12.25°C
	1700 to 1820°C* 3		—	
R	-50 to 0°C* 3		—	
	0 to 1600°C* 2	±4.0°C	±0.35°C	±12.75°C
	1600 to 1768°C* 3		—	
S	-50 to 0°C* 3		—	
	0 to 1600°C* 2	±4.0°C	±0.35°C	±12.75°C
	1600 to 1768°C* 3		—	
N	-270 to -200°C* 3		—	
	-200 to 1250°C* 2	±2.5°C	±0.2°C	±7.5°C
	1250 to 1300°C* 3		—	

* 1: If a value entered from the thermocouple is outside the measured temperature range given in the table, it is handled as the maximum/minimum value of the measured temperature range.

* 2: The accuracies in the shaded temperature ranges only are applied.

* 3: Temperature measurement can be made, but accuracy is not guaranteed.

* 4: It is the maximum temperature error in the case where the cold junction temperature compensation setting is set to "No".
If it is set to "Yes" for thermocouple K, for example, the maximum temperature error at the ambient temperature of 55°C is 9.5°C.

(3) Micro voltage input range and accuracies

The micro voltage input range and accuracies will be explained.

Input Type	Measurable Voltage Range	Conversion Accuracy	
		(At 25±5°C operating ambient temperature)	(At 0 to 55°C operating ambient temperature)
Micro voltage input	-80 to 80mV	±0.16mV	±0.32mV

3.1.1 Micro voltage I/O conversion characteristic

The factory-set micro voltage I/O conversion characteristic is shown below.

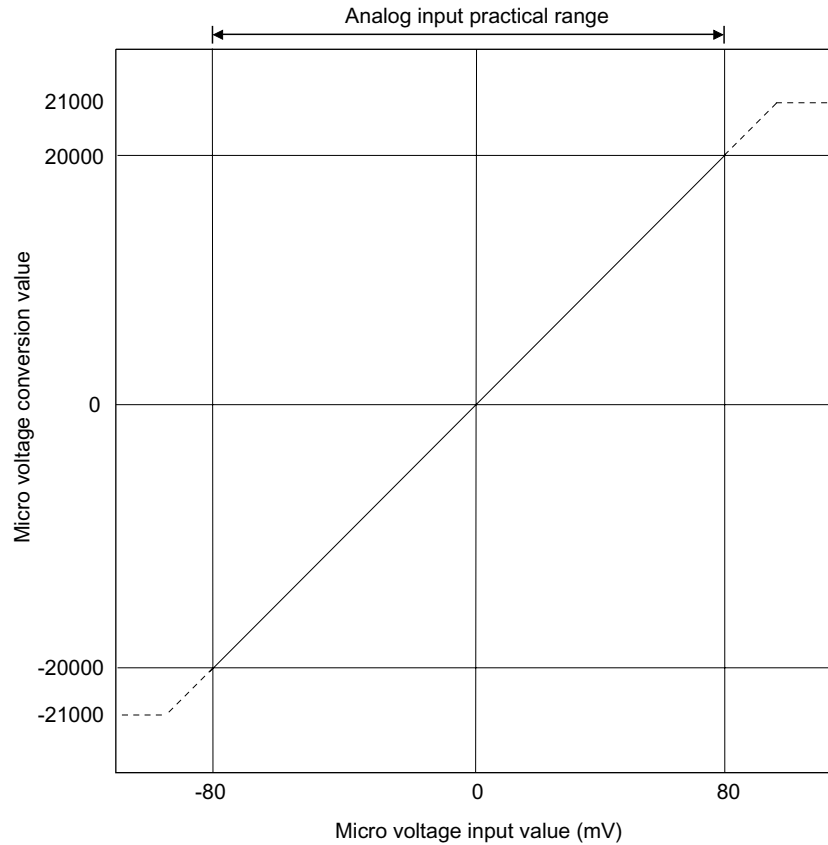
**POINT**

- (1) Use the module within the micro voltage input range and micro voltage conversion value.
Outside those ranges, the maximum resolution and accuracy may not fall within the ranges of the performance specifications. (Avoid using the dotted line areas in the chart.)
- (2) Do not input $\pm 4V$ or more. Doing so may damage the elements.
- (3) When a voltage exceeding the micro voltage conversion value range (-20000 to 20000) is input, the measured micro voltage value is fixed to the maximum (21000) or the minimum (-21000).

3.1.2 Conversion speed

The conversion speed of the ST1TD2 changes depending on the input type setting (user parameter) or the cold junction compensation setting (user parameter).

[Thermocouple input and cold junction temperature compensation set to "No", or micro voltage input]

(Conversion speed) = 30ms/1channel

[Thermocouple input and cold junction temperature compensation set to "Yes"]

(Conversion speed) = 60ms/1channel

3.1.3 Intelligent function module processing time

The ST1TD2 intelligent function module processing time is (CH1 conversion speed) + (CH2 conversion speed).

For the input transmission delay time, refer to the used head module user's manual.

3.2 Function

This section explains the functions of ST1TD2.

3.2.1 Function list

Table 3.1 lists the functions of ST1TD2.

Table 3.1 ST1TD2 Function List (1/3)

Item	Description	Reference section
Temperature conversion function	(1) The "thermal EMF value" input from the thermocouple is converted into a "temperature value" to detect a temperature. (2) Temperature data are 16-bit signed binary (-2700 to 18200) and stored into \boxed{Wr} word input area.	Section 3.2.2
Micro voltage conversion function	(1) This function converts a micro voltage within -80mV to 80mV into a 16-bit signed binary (-20000 to 20000) and stores it into the \boxed{Wr} word input area.	Section 3.2.3
Conversion enable/disable function	(1) This function specifies whether temperature/micro voltage conversion is enabled or disabled on each channel. (2) Processing time can be reduced by setting the temperature or micro voltage conversion function to be enabled or disabled. • Reduced time with cold junction temperature compensation: 60ms • Reduced time without cold junction temperature compensation: 30ms In addition, it prevents unnecessary disconnection detection of unused channels. (3) By default, the conversion for all channel is enabled. [Setting method] • Conversion enable/disable setting write (Command number: 2300H, see Section 8.4.1) • GX Configurator-ST (see Section 5.3)	—
Temperature/micro voltage conversion system	(1) Sampling process A temperature/micro voltage input value is converted one by one on each channel and a measured temperature value/micro voltage value is stored after every conversion. (2) Averaging process A temperature input value/micro voltage conversion value is averaged in terms of count or time on each channel and a digital average value is stored. (3) Setting for averaging process specification, time/count averaging specification, average time/average number of times can be done on each channel. (4) Sampling process/averaging process specification defaults to sampling process performed on all channels. (5) Time averaging defaults to 480ms, and number of times averaging defaults to 480 times. [Sampling process/averaging process specification, time/count averaging specification method] • Operation condition specification value write (Command number: 2302H, see Section 8.4.2) • GX Configurator-ST (see Section 5.3) [Average time/average number of times setting method] • CH \square average time/average number of times setting write (Command number: 2304H, see Section 8.4.3) • GX Configurator-ST (see Section 5.3)	Section 3.2.4
Disconnection detection function	(1) This function detects the disconnection of the connected thermocouple/micro voltage signal cable on each channel. (2) Disconnection detection is made on only the channels set for conversion enabled.	Section 3.2.5

Table 3.1 ST1TD2 Function List (2/3)

Item	Description	Reference section																				
Input type selection function	<p>(1) This function sets the input type per channel. (2) The input type is selectable from the following.</p> <table border="1" data-bbox="456 421 975 712"> <thead> <tr> <th>Input type</th> <th>Measured range</th> </tr> </thead> <tbody> <tr> <td>Thermocouple K (default)</td> <td>-270 to 1372°C</td> </tr> <tr> <td>Thermocouple E</td> <td>-270 to 1000°C</td> </tr> <tr> <td>Thermocouple J</td> <td>-210 to 1200°C</td> </tr> <tr> <td>Thermocouple T</td> <td>-270 to 400°C</td> </tr> <tr> <td>Thermocouple B</td> <td>0 to 1820°C</td> </tr> <tr> <td>Thermocouple R</td> <td>-50 to 1768°C</td> </tr> <tr> <td>Thermocouple S</td> <td>-50 to 1768°C</td> </tr> <tr> <td>Thermocouple N</td> <td>-270 to 1300°C</td> </tr> <tr> <td>Micro voltage input</td> <td>-80 to 80mV</td> </tr> </tbody> </table> <p>[Setting method] • Master station configuration software • GX Configurator-ST (see Section 5.3)</p>	Input type	Measured range	Thermocouple K (default)	-270 to 1372°C	Thermocouple E	-270 to 1000°C	Thermocouple J	-210 to 1200°C	Thermocouple T	-270 to 400°C	Thermocouple B	0 to 1820°C	Thermocouple R	-50 to 1768°C	Thermocouple S	-50 to 1768°C	Thermocouple N	-270 to 1300°C	Micro voltage input	-80 to 80mV	—
Input type	Measured range																					
Thermocouple K (default)	-270 to 1372°C																					
Thermocouple E	-270 to 1000°C																					
Thermocouple J	-210 to 1200°C																					
Thermocouple T	-270 to 400°C																					
Thermocouple B	0 to 1820°C																					
Thermocouple R	-50 to 1768°C																					
Thermocouple S	-50 to 1768°C																					
Thermocouple N	-270 to 1300°C																					
Micro voltage input	-80 to 80mV																					
Alarm output function	<p>(1) This function outputs an alarm when the temperature/micro voltage exceeds the range specified by the user. Setting can be done on each channel. (2) Alarm output setting default is set to No alarm output processing for all channels. (3) Set the 4 alarm output values: upper upper limit value, upper lower limit value, lower upper limit value and lower lower limit value. The upper upper limit value, upper lower limit value, lower upper limit value and lower lower limit value is set to 0 as defaults.</p> <p>[Alarm output setting method] • Operation condition specification value write (Command number: 2302H, see Section 8.4.2) • GX Configurator-ST (see Section 5.3)</p> <p>[Upper upper limit value, upper lower limit value, lower upper limit value and lower lower limit value setting method] • CH□ upper upper limit value/upper lower limit value setting write (Command number: 2308H, 230AH, see Section 8.4.4) • CH□ lower upper limit value/lower lower limit value setting write (Command number: 2309H, 230BH, see Section 8.4.5) • GX Configurator- ST (see Section 5.3)</p>	Section 3.2.6																				
Pt1000 cold junction temperature compensation setting function	<p>(1) This is a function to set yes/no cold junction temperature compensation by Pt1000 built in the base module for ST1TD2. Setting can be done on each channel. This function is effective for high-precision temperature measurement, such as the case where an error in Pt1000 cold junction temperature compensation accuracy (Ambient air temperature 25±5°C : ±1.5°C, Ambient air temperature 0 to 55°C: ±2.5°C) can not be ignored. The cold junction temperature compensation accuracy can be improved by disabling the cold junction temperature compensation of the Pt1000 and providing a precision ice bath externally.</p> <p>(2) Default is set to cold junction temperature compensation - yes. (3) Cold junction temperature compensation setting will be invalid in the mode of micro voltage input.</p> <p>[Setting method] • Master station configuration software • GX Configurator-ST (see Section 5.3)</p>	Section 3.2.7																				

Table 3.1 ST1TD2 Function List (3/3)

Item	Description	Reference section
Command	(1) By using commands, command parameters can be set, and the parameter settings can be written from RAM to ROM and read from ROM to RAM.	Chapter 8
Compensation of measured temperature/micro voltage value	<p>(1) The ST1TD2 can compensate the error between the "actual temperature/voltage" and the "measured temperature/voltage", which occurs due to various thermocouple accuracies, compensating lead length, installation condition, etc. To compensate the error, the 1-point compensation using the sensor compensation function and the 2-point compensation using the offset/gain setting can be used.</p> <p>1) Sensor compensation function When the measurement range is less than 100°C or 100 digits, use the sensor compensation function. The compensation value can be easily obtained in 1-point temperature/voltage measurement only.</p> <p>2) Offset/gain setting function When the measurement range is not less than 100°C or 100 digits, use the offset/gain setting function. A wide-range compensation is available.</p> <p>(2) For the sensor compensation or the offset/gain setting, prepare a thermometer to measure the temperature of the object. Compensation is performed based on the difference between the temperature measured by the thermometer and the one measured by the ST1TD2.</p>	—
Sensor compensation function	<p>(1) The measured temperature value or micro voltage conversion value is compensated based on the set sensor compensation value. The compensation is available for each channel.</p> <p>[Sensor compensation method]</p> <ul style="list-style-type: none"> • Sensor compensation value write (Command number : 231Ah, see Section 8.4.6) • GX Configurator-ST 	Section 3.2.8
Offset/gain setting function	<p>(1) Linear compensation is available by individually compensating any given 2 points (offset/gain value) within the effective range. The offset/gain setting can be made for each channel.</p> <p>(2) To use the user range setting, it needs to be set in the offset/gain value selection (user parameter) in advance. The offset/gain value selection can be made for each channel. Default is set to "factory default".</p> <p>[Offset/gain setting method]</p> <ul style="list-style-type: none"> • Master station program • GX Configurator-ST <p>[Offset/gain value selection method]</p> <ul style="list-style-type: none"> • Master station configuration software • GX Configurator-ST (see Section 5.3) 	Section 4.5
Online module change	<p>(1) A module change is made without the system being stopped.</p> <p>[Execution procedure]</p> <ul style="list-style-type: none"> • Button operation on the head module • GX Configurator-ST 	Chapter 7

3.2.2 Temperature conversion function

- (1) The "thermal EMF value" input from the thermocouple is converted into a "temperature value" to detect a temperature.
- (2) The value of the measured temperature to the first decimal place is multiplied by 10 and the result is stored into $[Wr.n], [Wr.n+1] CH$ measured temperature value/micro voltage value in 16-bit signed binary. (The second decimal place and on are rounded down.)
- (3) A negative measured temperature value is displayed as two's complement.
- (4) At power-on or reset, all channels are set to 0.

[Example 1] At the measured temperature value of 123.45°C 1234 is stored.

b15	b14	b13	b12	b11	b10	b9	b8	b7	b6	b5	b4	b3	b2	b1	b0
0	0	0	0	0	1	0	0	1	1	0	1	0	0	1	0

[Example 2] At the measured temperature value of -123.45°C -1234 is stored.

b15	b14	b13	b12	b11	b10	b9	b8	b7	b6	b5	b4	b3	b2	b1	b0
1	1	1	1	1	0	1	1	0	0	1	0	1	1	1	0

- (5) Processing time can be reduced by setting unused channels to be conversion-disabled.
 - Reduced time with cold junction temperature compensation: 60ms
 - Reduced time without cold junction temperature compensation: 30ms
 In addition, it prevents unnecessary disconnection of unused channels.
- (6) Acceptable input temperature range varies with each thermocouple. If any temperature outside of range is input, the measured temperature value will be fixed to the maximum or minimum of the selected thermocouple.

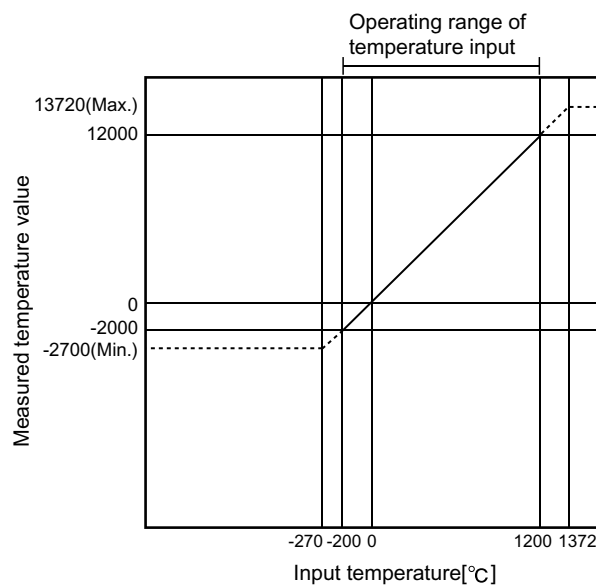

Figure 3.1 Conversion characteristic for thermocouple K

3.2.3 Micro voltage conversion function

- (1) A micro voltage of -80 to 80mV is converted into a 16-bit binary value of -20000 to 20000, then stored in $\boxed{\text{Wr.n}}$, $\boxed{\text{Wr. n+1}}$ CH \square measured temperature value/micro voltage conversion value.
- (2) A negative micro voltage conversion value is displayed as two's complement.
- (3) At power-on or reset, all channels are set to 0.

[Example 1] At the micro voltage input value of 51.300mV 12825 is stored.

b15	b14	b13	b12	b11	b10	b9	b8	b7	b6	b5	b4	b3	b2	b1	b0
0	0	1	1	0	0	1	0	0	0	0	1	1	0	0	1

[Example 2] At the micro voltage input value of -51.300mV -12825 is stored.

b15	b14	b13	b12	b11	b10	b9	b8	b7	b6	b5	b4	b3	b2	b1	b0
1	1	0	0	1	1	0	1	1	1	1	0	0	1	1	1

- (4) By setting unused channels to be conversion-disabled, the time of 30ms can be reduced.
- (5) If any voltage outside of range is input, the micro voltage conversion value will be fixed to the maximum (21000) or minimum (-21000).

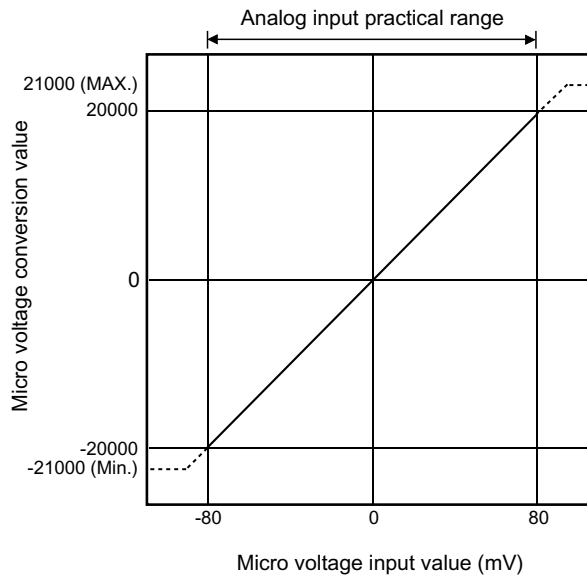

Figure 3.2 Micro voltage I/O conversion characteristic

3.2.4 Temperature/micro voltage conversion system

Temperature/micro voltage conversion can either be made by sampling processing or averaging processing.

Table 3.2 shows the processing times in combinations of the conversion enable/disable setting (command parameter), the input type setting (user parameter) and the cold junction temperature compensation setting (user parameter).

Table 3.2 CH□ processing time

Conversion enable/disable setting	Input type setting	Cold junction temperature compensation setting	Processing time/ 1 channel
Enable	Thermocouple K, E, J, T, B, R, S, N	Yes	60ms
		No	30ms
	Micro voltage input	-*	
Disable	Thermocouple K, E, J, T, B, R, S, N	Yes	0ms
		No	
	Micro voltage input	-*	

* Cold junction temperature compensation setting will be invalid during entry of micro voltage.

(1) Sampling process

Temperature or micro voltage input values are converted one by one, and the measured temperature value or micro voltage conversion value is stored into $Wr.n$, $Wr.n+1$ CH □ measured temperature value/micro voltage conversion value each time.

$$(\text{Sampling process}) = (\text{CH1 processing time}^*) + (\text{CH2 processing time}^*)$$

* The processing time varies depending on the conversion enable/disable setting (command parameter), the input type setting (user parameter) and the cold junction temperature compensation setting (user parameter). (See Table 3.2.)

[Example] In the following case, the sampling process time is 90ms.

Channel 1 setting

Conversion enable/disable setting : Enable

Input type setting : Thermocouple K

Cold junction temperature compensation setting : Yes

Channel 2 setting

Conversion enable/disable setting : Enable

Input type setting : Micro voltage input

Cold junction temperature compensation setting : -

$$\underline{60\text{ms}+30\text{ms}=90\text{ms}}$$

(2) Averaging process

The conversion is performed for the specified channel as many times as the setting or for the set time. Then the sum of the values other than the maximum and minimum ones is averaged and the results is stored in $\overline{Wr.n}$, $\overline{Wr.n+1}$ CH□ measured temperature value /micro voltage conversion value.

The applicable setting ranges for the time and number of times are given below. When the setting is outside the applicable range, the ERR. LED turns on and the conversion of the corresponding channel stops.

- Averaging processing by time: 480 to 5000ms
- Averaging processing by the number of times: 4 to 500

(a) When averaging process by time is set

The formula calculating the average number of conversions within the set time is shown below.

$$\frac{\text{(Number of average number of conversion)}}{\text{(Set time)}} = \frac{\text{(Set time)}}{\text{(CH1 processing time*) + (CH2 processing time*)}}$$

* The processing time varies depending on the conversion enable/disable setting (command parameter), the input type setting (user parameter) and the cold junction temperature compensation setting (user parameter). (See Table 3.2.)

[Example] In the following setting, the average number of conversions is 13.

Averaging time setting: 810ms

Channel 1 setting

Conversion enable/disable setting : Enable

Input type setting : Thermocouple K

Cold junction temperature compensation setting : No

Channel 2 setting

Conversion enable/disable setting : Enable

Input type setting : Micro voltage input

Cold junction temperature compensation setting : -

$$\underline{810\text{ms}/(30\text{ms}+30\text{ms})=13.5(\text{Round down the number})}$$

(b) When averaging process by number of times

The formula expressing the relation of the set number of times and the average processing time is shown below.

$$\text{(Average processing time)} = \text{(Set number of times)} \times \text{(CH1 processing time* + CH2 processing time*)}$$

* The processing time varies depending on the conversion enable/disable setting (command parameter), the input type setting (user parameter) and the cold junction temperature compensation setting (user parameter). (See Table 3.2.)

[Example] In the following setting, the average processing time is 30000ms.

Average number of times set: 500

Channel 1 setting

Conversion enable/disable setting : Enable

Input type setting : Thermocouple K

Cold junction temperature compensation setting : No

Channel 2 setting

Conversion enable/disable setting : Enable

Input type setting : Micro voltage input

Cold junction temperature compensation setting : -

$$\underline{500 \times (30\text{ms}+30\text{ms}) = 30000\text{ms}}$$

3.2.5 Disconnection detection function

- (1) If disconnection of a thermocouple, compensation lead wire, or the micro voltage signal line is detected, the ERR.LED will light up, and a system error will be stored in [Er. n+3] to [Er. n] CH □ error information. (Refer to section 3.3.2)
- (2) Disconnection is detected on only the channels set for conversion enabled.
- (3) Disconnection is detected on each channel.
- (4) If disconnection is detected, the measured temperature value or micro voltage conversion value right before the detection will be held.
- (5) The relationships between disconnection detection and conversion enable/disable setting are indicated below.

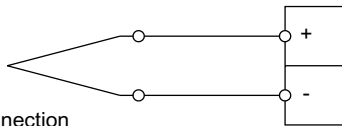
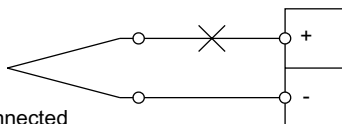
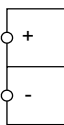
Connection Status	Conversion Enable/Disable Setting	Disconnection Detection Flag
No disconnection 	Enable	OFF
	Disable	
Disconnected 	Enable	ON
	Disable	OFF
No connection 	Enable	ON
	Disable	OFF

POINT
<ul style="list-style-type: none"> • Any channel where no thermocouple, compensation lead wire or micro voltage signal line is connected must be set to "conversion disable". If unconnected channel is set as conversion-enabled, disconnection is detected. • If disconnection is detected, measured temperature value and micro voltage conversion value immediately before detection is kept, then [Br.n+2] conversion completion flag turns off (0). If connection is restored after disconnection is detected, updating of measured temperature value and micro voltage conversion value re-starts, then [Br.n+2] conversion completion flag turns on (1). • If a value greater than 80mV is entered, wire disconnection may be detected. Use the module within the allowable range of each input type. • Use the module within the allowable input range of each input type. If an analog value exceeding the input range is entered, wire disconnection will be detected. • Refer to Section 4.4 for the wiring of the thermocouple, compensation lead wire or micro voltage signal cable. • Refer to Section 9.2.3 for the troubleshooting of disconnection detection.

3.2.6 Alarm output function

- (1) If a detected measured temperature value/micro voltage conversion value rises to or above the upper upper limit value or falls to or below the lower lower limit value and enters the alarm output range, $\overline{\text{Br.n+1}}$ alarm output signal turns on (1) and the alarm information is stored into $\overline{\text{Er.n+3}}$ to $\overline{\text{Er.n}}$ CH□ error information.
(Refer to Section 3.3.2)
- (2) When the measured temperature value/micro voltage conversion value falls below the upper lower limit value or rises above the lower upper limit value and returns to within the setting range after the alarm output, $\overline{\text{Er.n+3}}$ to $\overline{\text{Er.n}}$ CH□ error information of the corresponding channel is automatically cleared.
 $\overline{\text{Br.n+1}}$ alarm output signal turns off (0) only when values detected on all channels return to within the setting range.
- (3) Alarm output processing can be specified for each channel.
The default is set to No alarm output processing performed on all channels.
- (4) Set the 4 alarm output values: upper upper limit value, upper lower limit value, lower upper limit value and lower lower limit value.
If a channel setting does not meet the condition shown in (a) and (b), it is considered as an error and the ERR.LED will light up.
(a) Setting range on each input type is shown below.
Setting of thermocouple input is performed in 0.1°C unit.
[Example] To set to 0.3°C Enter "3".

Input type	Setting range (Accuracy guarantee range)
Thermocouple K	-2700 to 13720 (-2000 to 12000)
Thermocouple E	-2700 to 10000 (-2000 to 9000)
Thermocouple J	-2100 to 12000 (-400 to 7500)
Thermocouple T	-2700 to 4000 (-2000 to 3500)
Thermocouple B	0 to 18200 (6000 to 17000)
Thermocouple R	-500 to 17680 (0 to 16000)
Thermocouple S	-500 to 17680 (0 to 16000)
Thermocouple N	-2700 to 13000 (-2000 to 12500)
Micro voltage input	-21000 to 21000 (-20000 to 20000)

- (b) The following is a conditional expression of the setting value.
Lower lower limit value ≤ lower upper limit value ≤ upper lower limit value ≤ upper upper limit value

(5) An alarm is output for only the channel for which conversion is enabled.

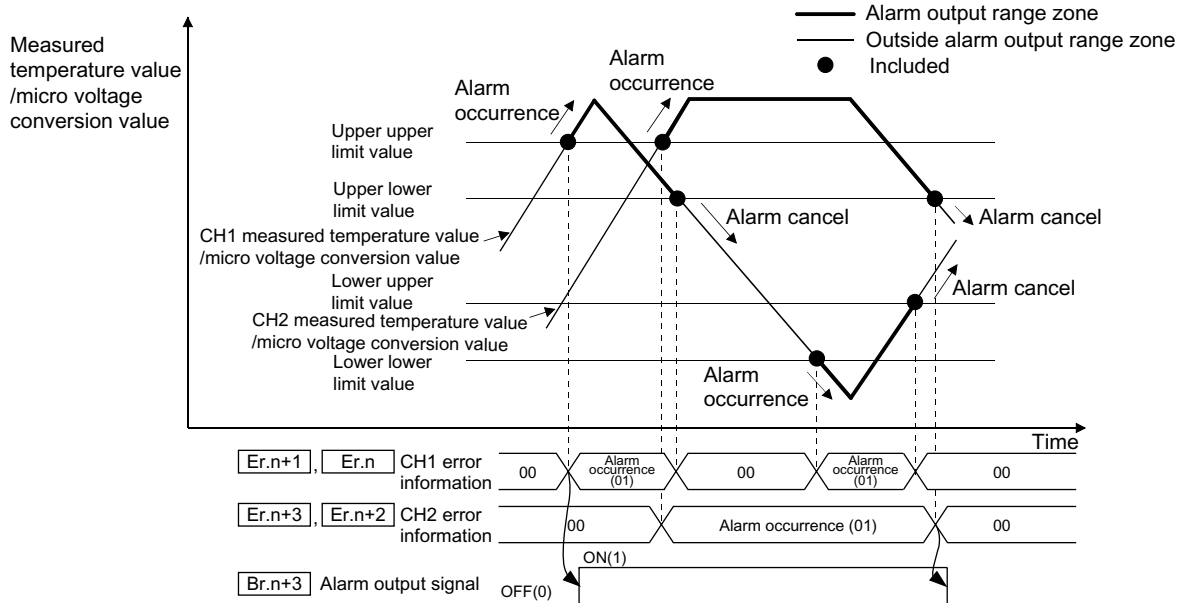

3.2.7 Cold junction temperature compensation setting

ST1TD2 can perform the following two kind of cold junction temperature compensation by selecting Yes/No of cold junction temperature compensation with Pt1000 temperature-measuring resistor using configuration software at the master station.

(1) Using Pt1000 temperature-measuring resistor to perform cold junction temperature compensation (cold junction temperature compensation set to "Yes")

Cold junction temperature compensation is performed automatically by a Pt1000 temperature-measuring resistor built in a base module for ST1TD2.

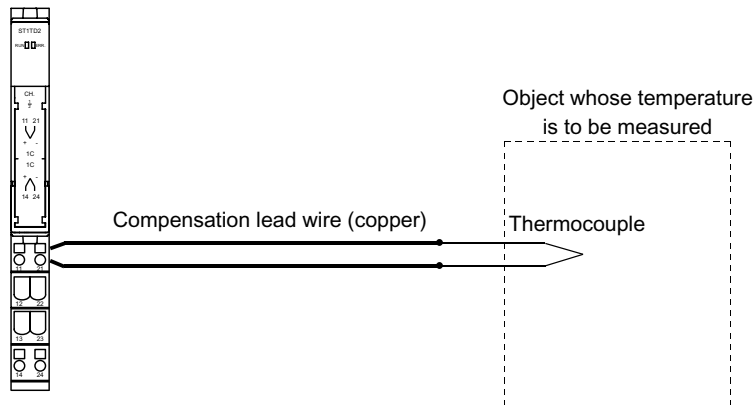

(2) Performing cold junction temperature compensation externally (cold junction temperature compensation set to "No")

Use this function for high-precision temperature measurement, such as the case where an error in cold junction temperature compensation accuracy (Ambient air temperature $25 \pm 5^\circ\text{C}$: $\pm 1.5^\circ\text{C}$, Ambient air temperature 0 to 55°C : $\pm 2.5^\circ\text{C}$) by Pt1000 temperature-measuring resistor built in a base module for ST1TD2 can not be ignored.

By providing a precision ice bath externally, the thermoelectromotive force generated at the tip of the thermocouple can be led to this module without any change, improving the cold junction temperature compensation accuracy.

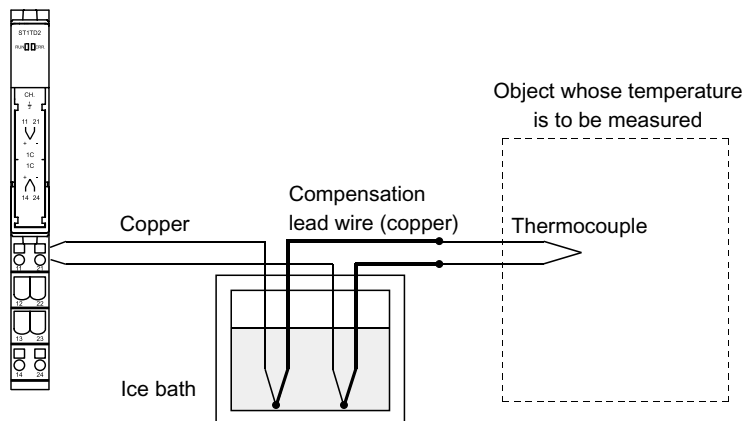

POINT

The ice bath is designed to connect the thermocouple and a lead wire in the pot whose internal temperature is controlled to be 0°C . Hence, the thermoelectromotive force at the contact portion of the thermocouple and lead wire will be 0mV , preventing the generation of extra thermoelectromotive force which can cause errors.

3.2.8 Sensor compensation function

- (1) Various thermocouple accuracies, compensating lead length, installation condition, etc. can result in an error between the "actual temperature/voltage" and the "measured temperature/voltage".

The sensor compensation function corrects the error.

The measured temperature value or micro voltage conversion value is compensated based on the set sensor compensation value.

The compensation is available for each channel.

- (2) The setting range is -500 to 500.

In the case of thermocouple input, set the value in units of 0.1°C.

The setting for the micro voltage input is performed in units of 4μV/digit.

Example 1) When the measured temperature (501.5°C) is higher than the actual temperature (500.0°C) by 1.5°C, set -15 as the sensor compensation value.

$$500.0(°C) - 501.5(°C) = -1.5(°C)$$

$$-1.5(°C) \times 10 = -15$$

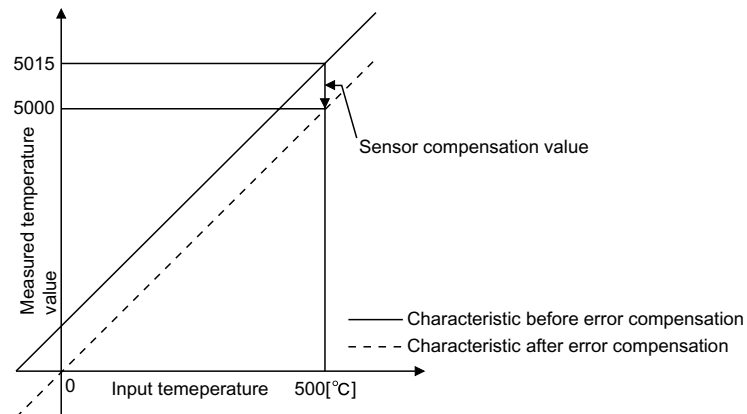

Example 2) When the micro voltage conversion value is 10003 at 40mV input, set -3 as the sensor compensation value.

$$10000 - 10003 = -3$$

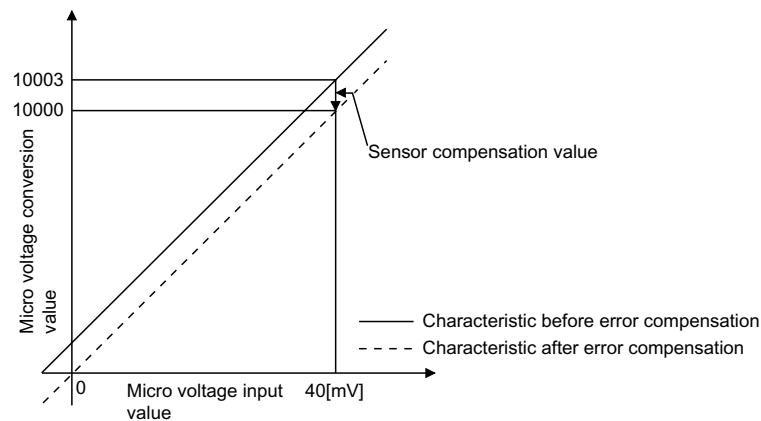

3.3 I/O Data

The ST1TD2 has the areas for data transfer with the head module as indicated in Table 3.3.

This section explains the composition of each area.

Table 3.3 I/O Data List

Transfer direction	Item	Number of Occupancy	Default value	Reference section	
ST1TD2 → Head module (Input Data)	Br Bit Input Area	4	0	Section 3.3.1	
	Information Area	Er Error Information Area	4	0	Section 3.3.2
		Mr Module Status Area	2	0	Section 3.3.3
	Wr Word Input Area	2	0	Section 3.3.4	
Head module → ST1TD2 (Output Data)	Bw Bit Output Area	4	0	Section 3.3.5	
	Request Area	Ew Error Clear Area	4	0	Section 3.3.6
	Ww Word Output Area	2	0	Section 3.3.7	

3.3.1 Bit input area

This section explains the **Br** bit input area.

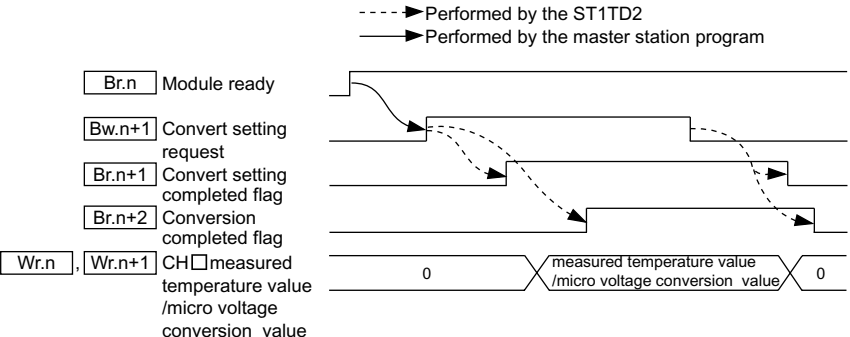
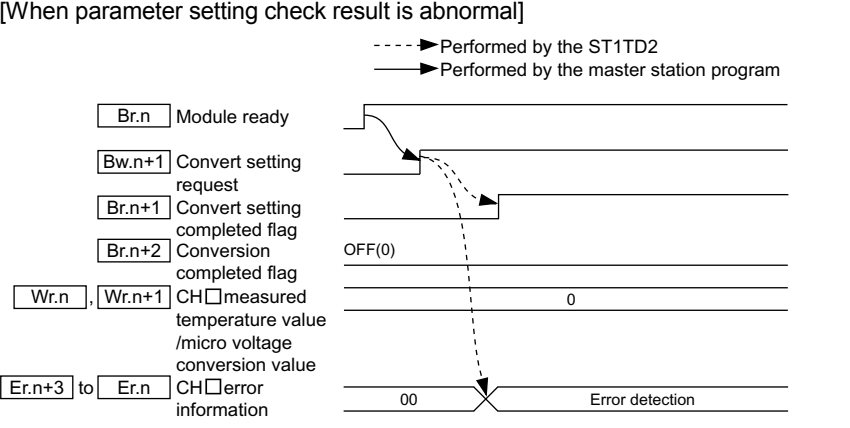
Bit input	Item	Description
Br.n	Module ready	<p>(1) Turns on (1) when conversion is ready after the MELSEC-ST system (ST1TD2) is powered on or the head module is reset.</p> <p>(2) When the Br.n Module ready signal is off (0), conversion processing is not performed.</p> <p>Br.n Module ready turns off (0) in the following situations:</p> <ul style="list-style-type: none"> • In offset/gain setting mode • When the ST1TD2 has a watchdog timer error • In module change enabled status during online module change (refer to Chapter 7)
Br.n+1	Convert setting completed flag	<p>(1) After Bw.n+1 convert setting request has turned on (1), this turns on (1) when user parameter and command parameter setting check is completed. (Turns on (1) if a setting error is detected.)</p> <p>[When parameter setting check result is normal]</p>  <p>[When parameter setting check result is abnormal]</p> 

Bit input	Item	Description
<p>Br.n+2</p>	<p>Conversion completed flag</p>	<p>(1) After Bw.n+1 convert setting request has turned on (1), Br.n+2 conversion completed flag turns on (1) when conversion is completed on all channels for which conversion is enabled.</p> <p>(2) The Br.n+2 conversion completed flag is processed only once when the Bw.n+1 convert setting request is changed.</p> <p>(a) When Bw.n+1 convert setting request is turned from off (0) to on (1) When the measured temperature value / micro voltage conversion value is stored into Wr.n, Wr.n+1 CH□ measured temperature value/micro voltage conversion value, Br.n+2 conversion completed flag turns on (1). Specifying averaging process will cause a delay in turning Br.n+2 conversion completed flag on (1) by the processing time.</p> <p>(b) When Bw.n+1 convert setting request is turned from on (1) to off (0) Br.n+2 conversion completed flag turns off (0).</p> <p>(3) When disconnection is detected on any of the conversion-enabled channels, Br.n+2 conversion complete flag turns OFF (0). When connection is restored after the disconnection detection, updating of the measured temperature value/micro voltage conversion value is resumed and Br.n+2 conversion complete flag turns ON (1) again.</p>
<p>Br.n+3</p>	<p>Alarm output signal</p>	<p>(1) Turns on (1) when the measured temperature value/micro voltage conversion value falls outside the setting range for the CH□ upper upper limit value/upper lower limit value (command parameter) and CH□ lower upper limit value/lower lower limit value (command parameter) on either channel where the alarm output is validated and conversion is enabled.</p> <p>(2) Turns off (0) automatically when the measured temperature value/micro voltage conversion value returns to within the setting range on all channels for which enabled conversion is enabled.</p> <div style="text-align: center;"> <p>-----▶ Performed by the ST1TD2</p> </div>

3.3.2 Error information area

This section explains the **Er** error information area.

Error information		Item	Description														
Er.n+1	Er.n	CH1 error information	(1) Stores the error information or alarm information when an error or alarm occurs. (2) The stored error information can be cleared by turning on (1) the Ew.n error clear request. (Refer to Section 3.3.6) (3) If an alarm and a system error occur at the same time, a system error takes precedence and will be written over the area. (4) The alarm information is automatically cleared when the measured temperature value/micro voltage conversion value returns to within the setting range. (Refer to Section 3.3.1.)														
Er.n+3	Er.n+2	CH2 error information	<table border="1"> <thead> <tr> <th>Er.n+1</th> <th>Er.n</th> <th rowspan="2">Information</th> </tr> </thead> <tbody> <tr> <th>Er.n+3</th> <th>Er.n+2</th> </tr> <tr> <td>0</td> <td>0</td> <td>Normal</td> </tr> <tr> <td>0</td> <td>1</td> <td>Alarm has occurred</td> </tr> <tr> <td>1</td> <td>1</td> <td>System error has occurred</td> </tr> </tbody> </table>	Er.n+1	Er.n	Information	Er.n+3	Er.n+2	0	0	Normal	0	1	Alarm has occurred	1	1	System error has occurred
Er.n+1	Er.n	Information															
Er.n+3	Er.n+2																
0	0	Normal															
0	1	Alarm has occurred															
1	1	System error has occurred															

3.3.3 Module status area

This section explains the **Mr** module status area.

Module status		Item	Description											
Mr.n+1	Mr.n	Module status	(1) The operating status of the ST1TD2 is stored.											
			<table border="1"> <thead> <tr> <th>Mr.n+1</th> <th>Mr.n</th> <th rowspan="2">Information</th> </tr> </thead> <tbody> <tr> <th>0</th> <th>0</th> </tr> <tr> <td>0</td> <td>0</td> <td>Online module change in progress or internal bus error occurred</td> </tr> <tr> <td>1</td> <td>1</td> <td>Normal</td> </tr> </tbody> </table>	Mr.n+1	Mr.n	Information	0	0	0	0	Online module change in progress or internal bus error occurred	1	1	Normal
Mr.n+1	Mr.n	Information												
0	0													
0	0	Online module change in progress or internal bus error occurred												
1	1	Normal												

3.3.4 Word input area

This section explains the **Wr** word input area.

Word input	Item	Description
Wr.n	CH1 measured temperature value/micro voltage conversion value	(1) The measured temperature value/micro voltage conversion value converted from an analog value is stored into Wr.n , Wr.n+1 CH□ measured temperature value/micro voltage conversion value for each channel. (2) The digital value is stored in 16-bit signed binary.
Wr.n+1	CH2 measured temperature value/micro voltage conversion value	

3.3.5 Bit output area

This section explains the Bw bit output area.

Bit output	Item	Description
$Bw.n$	System area	Use prohibited (fixed to 0)
$Bw.n+1$	Convert setting request	<p>(1) Turn this item from off (0) to on (1) to validate the settings of the user parameter and command parameter.</p> <p>(a) When writing the command parameter, make sure to turn the $Bw.n+1$ convert setting request off (0) to stop the conversion. When it is on (1), the command parameter cannot be written.</p> <p>(b) Regardless of whether the $Bw.n+1$ convert setting request is on (1) or off (0), the user parameter are written but not validated. (Turn the $Bw.n+1$ convert setting request from off (0) to on (1).)</p> <p>(2) Turn this on (1) to start conversion for the channel for which conversion set to be enabled in the conversion enable/disable setting (command parameter). When it turns off (0), the conversion is stopped.</p> <p>(3) For the on (1)/off (0) timing, refer to the $Br.n+1$ column in Section 3.3.1.</p> <p>OFF (0): Conversion stop (Default) ON (1): Conversion start</p>
$Bw.n+2$	System area	Use prohibited (fixed to 0)
$Bw.n+3$		

3.3.6 Error clear area

This section explains the Ew error clear area.

Error clear area	Item	Description
$Ew.n$	Error clear request	<p>(1) Turn this request on (1) to clear the $Er.n+3$ to $Er.n$ CH□ error information. (2) After confirming that the $Er.n+3$ to $Er.n$ CH□ error information has been cleared, turn off (0) the $Ew.n$ error clear request.</p> <p>OFF (0): No error clear requested (Default) ON (1): Error clear requested</p> <p>-----▶ Performed by the ST1TD2 ———▶ Performed by the master station program</p>
$Ew.n+1$	System area	Use prohibited (fixed to 0)
$Ew.n+2$		
$Ew.n+3$		

3.3.7 Word output area

The ST1TD2 does not use the Ww word output area since it is operational without reserving the area.

To make effective use of the Ww word output area, select "ST1TD2 (without Ww)" using the configuration software of the master station or GX Configurator-ST. The number of occupancy of the Ww word output area in the ST1TD2 is 0.

3.4 Memory and Parameters

This section explains the memory and parameters of the ST1TD2.

3.4.1 Memory

RAM and ROM are available as the parameter storage memory of the ST1TD2.

(1) RAM

- (a) The ST1TD2 operates based on the parameter settings stored in the RAM.
- (b) The parameter settings stored in the RAM become valid when the Bw.n+1 convert setting request turns from OFF to ON.

(2) ROM

- (a) The ROM stores the parameters. The stored parameters are not erased at power-off.
- (b) The parameters stored in the ROM are transferred to the RAM when:
 - The MELSEC-ST system (ST1TD2) is powered off, then on.
 - The head module is reset.
 - Parameter setting ROM read (command number: 3300H) is executed.

3.4.2 Parameters

The ST1TD2 has user parameters and command parameters.

(1) User parameters

(a) Setting item

- Input type setting
- Offset/gain value selection
- Cold junction temperature compensation setting

(b) Setting method

Set the parameters using the configuration software of the master station. When the MELSEC-ST system is tested alone, set the parameters using GX Configurator-ST.

(2) Command parameters

(a) Setting item

- Conversion enable/disable setting
- Sampling process/averaging process specification
- Time/count averaging specification
- Average time/average number of times setting
- Alarm output setting
- Upper upper limit value/upper lower limit value/lower upper limit value/lower lower limit value setting
- Sensor compensation value setting

(b) Setting method

1) Command

Execute a command from the master station to write the settings to the RAM of the ST1TD2.

When the command parameters are written in advance using Parameter setting ROM write (command number: 3301H), master station program steps can be reduced.

2) GX Configurator-ST

Use of GX Configurator-ST allows the parameters to be easily set on-screen, reducing master station program steps.

Write and save the settings, which are used for a MELSEC-ST system startup, to the ROM. (Use write to RAM when conducting a test temporarily.)

4 SETUP AND PROCEDURES BEFORE OPERATION

4.1 Handling Precautions

- (1) Do not drop the module or give it hard impact since its case is made of resin.
Doing so can damage the module.
- (2) Do not disassemble or modify the modules.
Doing so could cause failure, malfunction, injury or fire.
- (3) Be careful not to let foreign particles such as swarf or wire chips enter the module.
They may cause a fire, mechanical failure or malfunction.

4.2 Setup and Procedure before Operation

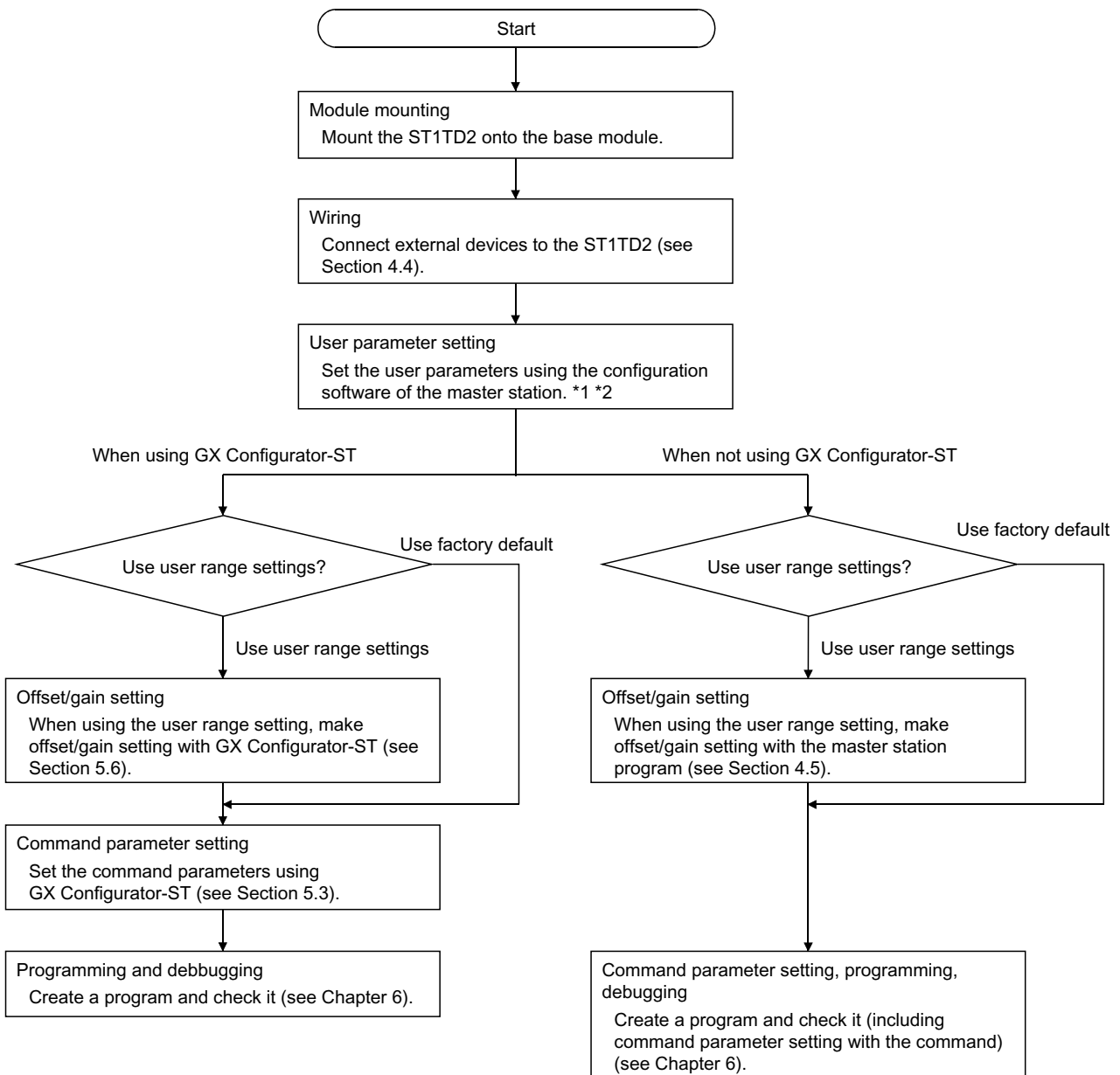

*1 When using the user range setting, set the offset/gain value selection (user parameter) as "user range setting".
 *2 If executing offset / gain setting in the program, set the input type setting (user parameter) appropriate for the offset/gain setting.
 (If making the offset / gain setting with GX Configurator-ST, set the input type using GX Configurator-ST.)

POINT
 Refer to Section 3.4 for details of the user parameter and command parameter.

4.3 Part Names

The name of each part in the ST1TD2 is listed below.

The following shows the ST1TD2 mounted on the spring clamp type base module.

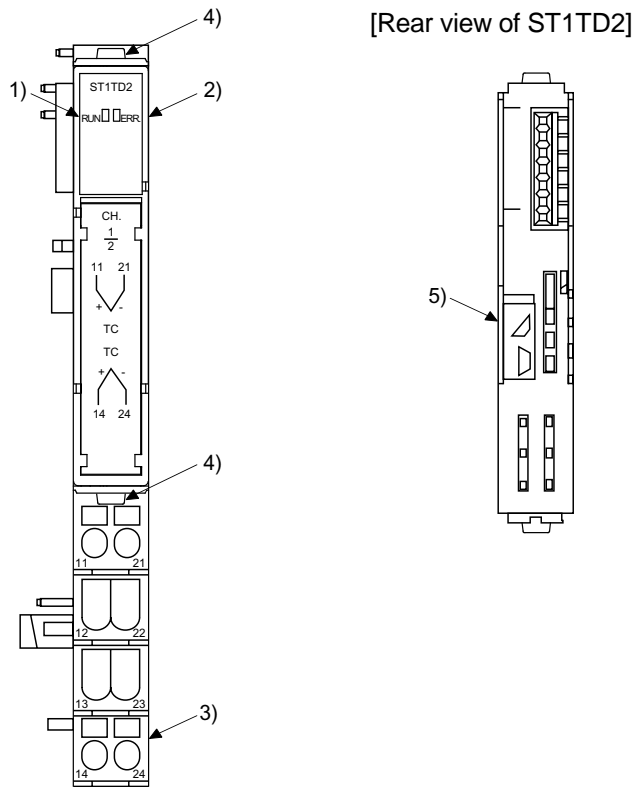

No.	Name and appearance	Description
1)	RUN LED	RUN LED and ERR. LED (on/flashing/off) indicate various statuses of the ST1TD2 (see section 4.3.1).
2)	ERR. LED	
3)	Terminal block	The input signal wires of the ST1TD2 are connected to the terminal block of the base module. [Applicable base modules] Spring Clamp Type : ST1B-S4TD2 Screw Clamp Type : ST1B-E4TD2
4)	Slice module fixing hooks (at both ends)	Used for mounting/dismounting the ST1TD2 to/from the base module. While pressing the hooks at both ends, mount/dismount the ST1TD2.
5)	Coding element	Prevents the module from being mounted incorrectly. The coding element consists of two pieces, and its shape varies depending on the model name. When the ST1TD2 is mounted on the base module and then dismantled, one piece of the coding element remains on the base module, and the other remains on the ST1TD2. The ST1TD2 can be mounted onto the base module only when the two pieces of the coding elements are matched. [Applicable coding element] ST1TD2 : ST1A-CKY-16

POINT	In order to ensure safety, make sure to attach the coding element to the base module and ST1TD2.
--------------	--------------------------------------------------------------------------------------------------

Terminal No.	Signal name		Terminal No.	Signal name	
11	CH1	TC+	21	CH1	TC-
12	Vacancy		22	Vacancy	
13	Vacancy		23	Vacancy	
14	CH2	TC+	24	CH2	TC-

4.3.1 Status confirmation by LED

Table 4.1 explains the LED indications.

Table 4.1 LED Indications

LED indication		Operating status
RUN LED	ERR.LED	
On	Off	Normal
	On	System error is occurring
Flashing (1s interval)	Off	The data communication has stopped or the parameter communication is faulty between the master module and head module, other slice module is faulty or an internal bus error is occurring.
	On	System error is occurring when the data communication has stopped or the parameter communication is faulty between the master module and head module, other slice module is faulty or an internal bus error has occurred.
Flashing (0.5s interval)	Off	Module is in offset/gain setting mode.
	On	System error is occurring in offset/gain setting mode.
Flashing (0.25s interval)	Off	Module is selected as the target of online module change.
	On	System error is occurring when module is selected as the target of online module change.
Off	Off	Power is off or online module change is being made.
	On	System error is occurring during online module change.

4.4 Wiring

The wiring precautions and examples of module connection are provided in this section.

4.4.1 Wiring precautions

In order to optimize the functions of the ST1TD2 and ensure system reliability, external wiring, that is protected from noise, is required.

Please observe the following precautions for external wiring:

- (1) Use separate cables for the AC control circuit and the external input signals of the ST1TD2 to avoid the influence of the AC side surges and inductions.
- (2) Do not bring/install the cables closer to/together with the main circuit line, a high-voltage cable or a load cable from other than the MELSEC-ST system. Doing so may increase the effects of noise, surges and induction.
- (3) Always place the thermocouple/micro voltage signal cable at least 100mm (3.94inch) away from the main circuit cables and AC control lines.
Fully keep it away from high-voltage cables and circuits which include harmonics, such as an inverter's load circuit.
Not doing so will make the module more susceptible to noises, surges and inductions.

4.4.2 External wiring

Connect the cables to the base module (sold separately).

(1) Thermocouple

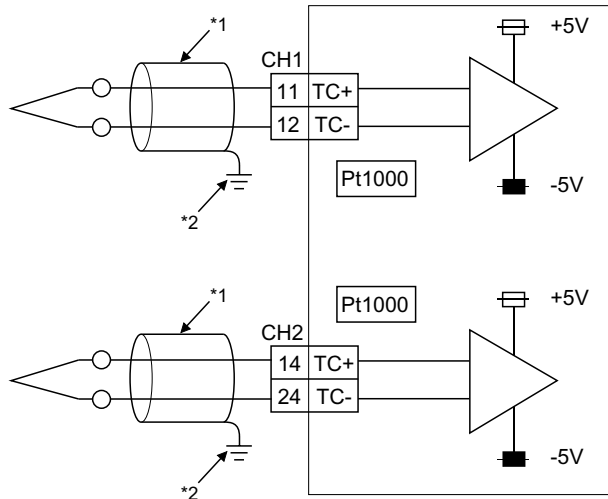

*1 As cables, always use shielded compensation conductors. Also, wire the shielded cables as short as possible.

*2 Ground the shield through the cable clamp or terminal block. Depending on noise conditions, however, it is recommended to ground the shield on the external device side.

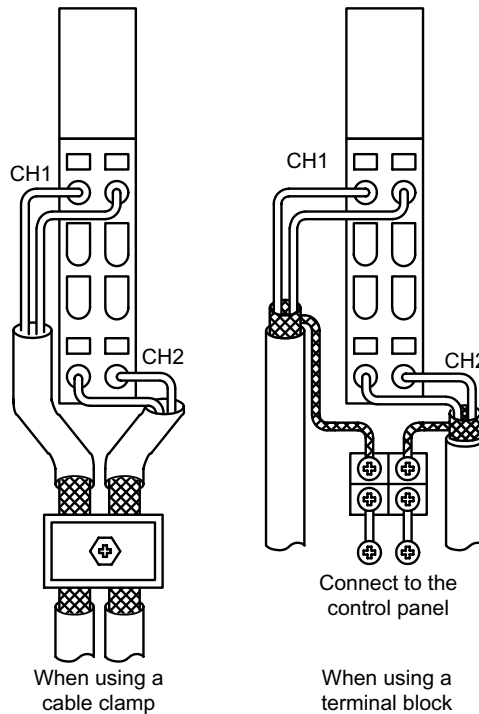

(2) Micro voltage signal

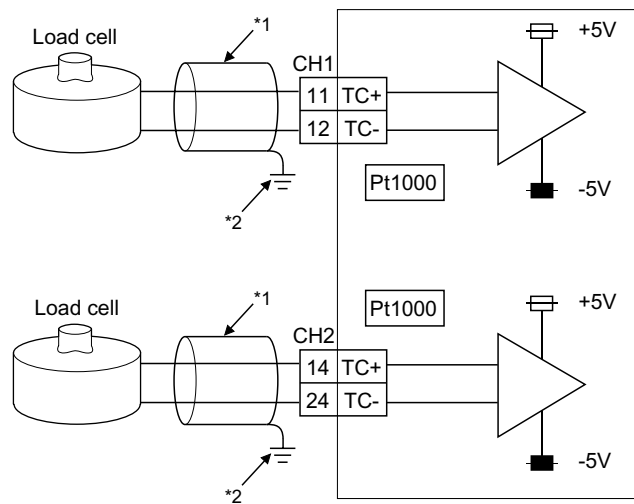

- *1 As cables, always use shielded conductors.
Also, wire the shielded cables as short as possible.
- *2 Ground the shield through the cable clamp or terminal block.
Depending on noise conditions, however, it is recommended to ground the shield on the external device side.

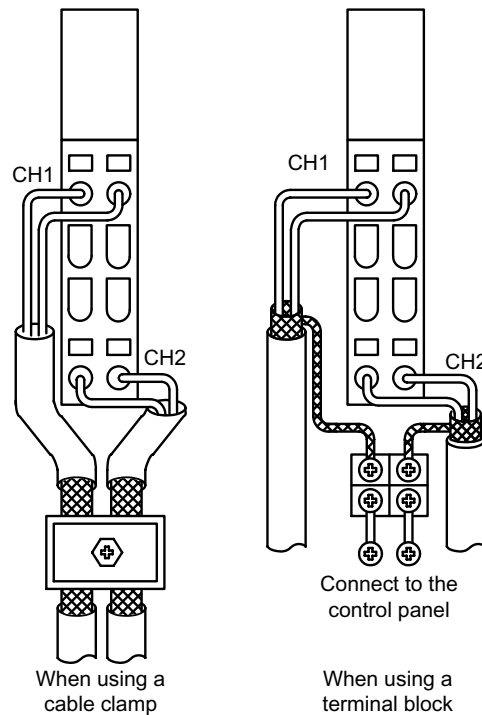

POINT

Any channel where no thermocouple, compensation conductor or micro voltage signal cable is connected must be set to "conversion disable".
If unconnected channel is set as conversion enable, disconnection is detected.

4.5 Offset/gain Setting

This section explains the offset/gain setting.

- (1) The offset/gain setting is a function designed to compensate for the value at any two points (offset value/gain value) within the operating range when the proper measured temperature value/micro voltage conversion value is not available at system startup or when the input type is changed.
- (2) The following are the relationships between the measured temperature value/micro voltage conversion value and respective input value corrected by the offset value/gain value.

(a) Thermocouple input

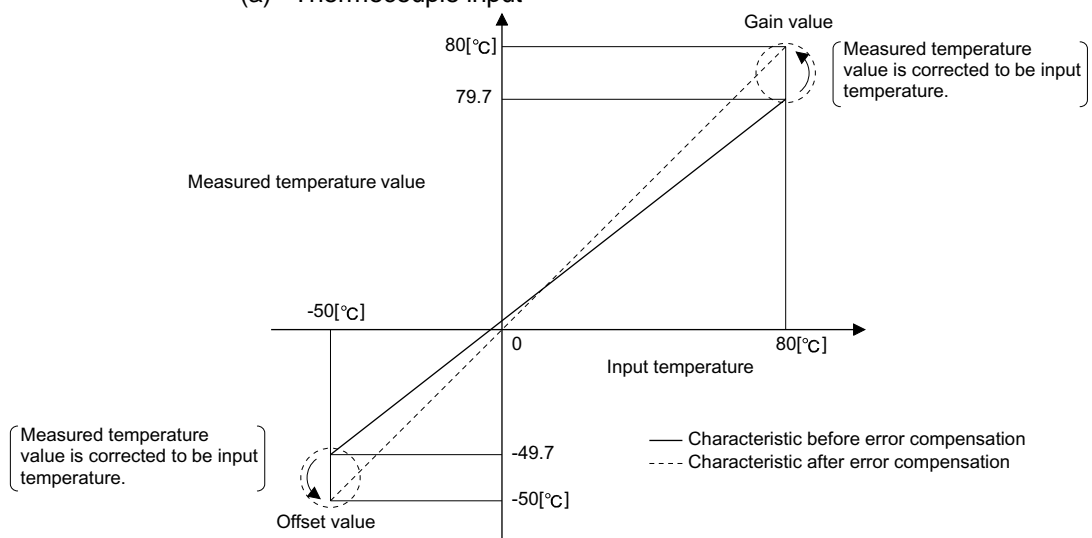

(b) Micro voltage input

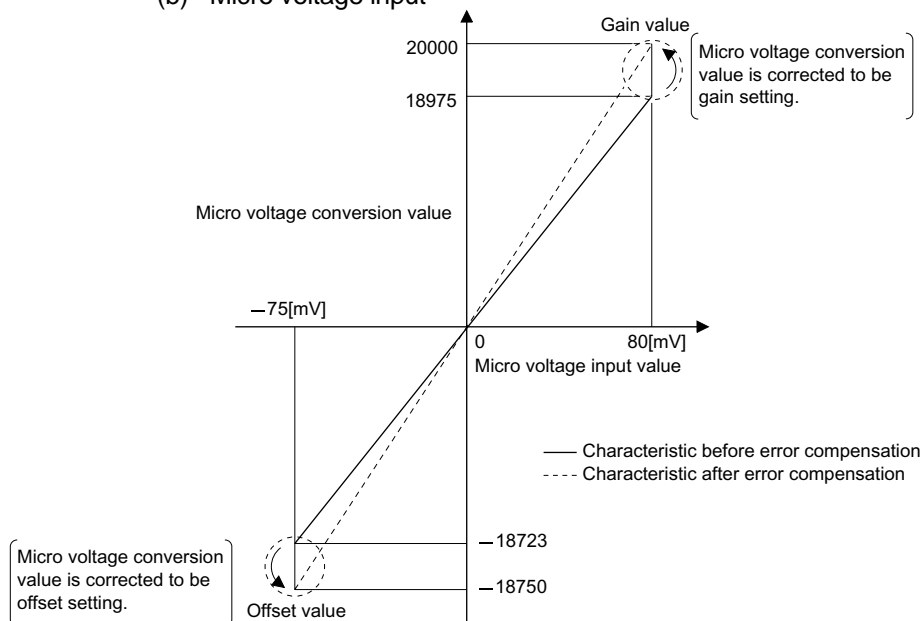

POINT			
<p>(1) Make the offset/gain setting within the measured temperature guarantee range (refer to Section 3.1 (2), or within the measurable voltage range (refer to Section 3.1 (3)). If the setting is made outside these ranges, the resolution and accuracy may not fall within the ranges of the performance specifications.</p> <p>(2) Obtain the offset value and gain value in the status of actual use. After the setting is completed, make sure that the offset value and gain value are set correctly in the status of actual use.</p> <p>(3) The offset and gain values are stored into the ROM and are not erased at power-off.</p> <p>(4) When making the offset/gain setting, write the values to the ROM using User range write (command number: 3305H). Data can be written to the ROM up to 10,000 times. To prevent accidental write to the ROM, write to ROM is counted from the time of power-on.</p> <p>(5) If an error occurs during offset/gain setting, the offset and gain values are not written to the ST1TD2. Set the correct offset and gain values again.</p> <p>(6) High accuracy is ensured when the offset and gain values are set as the minimum and maximum values of the operating range.</p> <p>(7) High accuracy can be obtained if the offset/gain setting is done after 30-minute power-up.</p> <p>(8) Always set the offset and gain values so that they will satisfy the following conditions. An error will occur if any of the conditions are not satisfied. Condition 1: Within the input enabled range Condition 2: Offset value < Gain value Condition 3: (Gain value) - (offset value) > 0.2 [°C] (for temperature input) or (Gain value) - (offset value) > 20 [μV] (for micro voltage input)</p> <p>(9) For thermocouple input, error compensation may also be made using a standard DC voltage generator or like instead of inputting a temperature directly to the thermocouple.</p> <table border="1" style="width: 100%; border-collapse: collapse;"> <tr> <td style="padding: 5px;">Power value of standard DC voltage generator</td> <td style="text-align: center; padding: 5px;">=</td> <td style="padding: 5px;">Thermoelectromotive force value of thermocouple used as offset/gain value relative to input temperature</td> </tr> </table>	Power value of standard DC voltage generator	=	Thermoelectromotive force value of thermocouple used as offset/gain value relative to input temperature
Power value of standard DC voltage generator	=	Thermoelectromotive force value of thermocouple used as offset/gain value relative to input temperature	

4.5.1 Offset/gain settings procedure

If using the user range setting, perform the offset/gain setting in the procedure shown in the section 4.5.1(1) or 4.5.1(2).

When the factory default is used, the offset/gain setting is not necessary.

If the GX Configurator-ST has been installed, perform the offset/gain settings according to the procedure described in Section 5.6.

(1) Offset/gain setting for thermocouple input

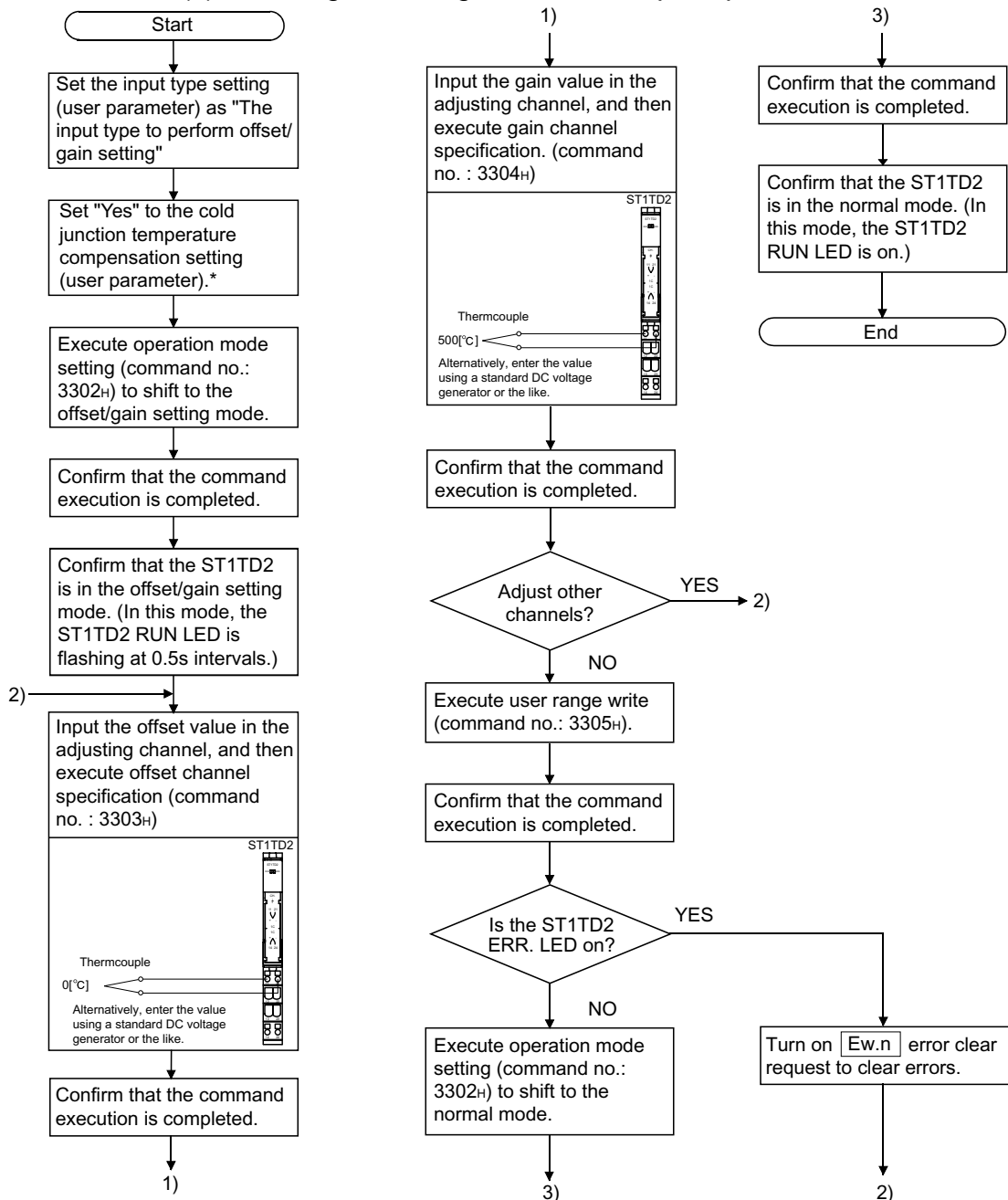

* When inputting a value with a standard D/C voltage generator or when actually using the module with the cold junction temperature compensation setting set to "No", set the cold junction temperature compensation setting to "No".

(2) Offset/gain setting for micro voltage input

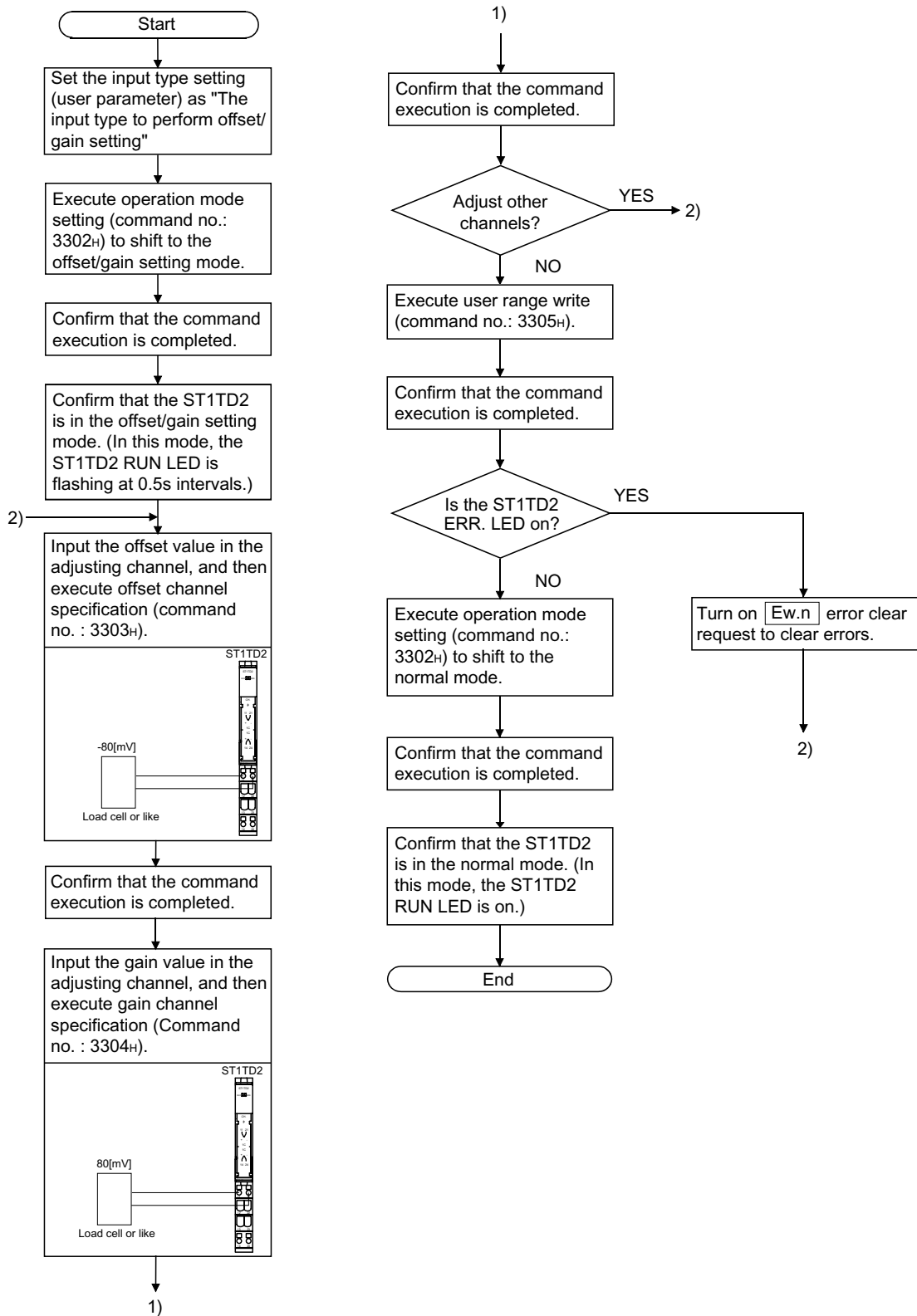

(3) Programming

The program examples are given in this section, showing the mode switching (between the normal mode and the offset/gain setting mode), the channel specification for the offset/gain setting, the offset/gain value adjustment, and the offset/gain value writing to the ST1TD2.

(a) When QJ71PB92D is used as master station

The program example is based on the system configuration given in Section 6.2.

1) Device assignment in program examples

Devices used by QJ71PB92D

Device	Application	Device	Application
X0	Exchange start end signal	Y0	Exchange start request signal
X1B	Communication READY signal		—
X1D	Module READY signal		
X1F	Watchdog timer error signal		

Devices used by user

Device	Application	Device	Application
X20	PROFIBUS-DP exchange start command	M0	Refresh start request
X25	Offset/gain setting mode select signal		—
X26	Offset channel specification signal		
X27	Gain channel specification signal		
X28	User range write signal		
X29	Normal mode select signal		

Devices used in I/O data

Br Bit input area

Br.n Bit input	Information	Master station side device	Slice No.	Module name
Br.00	Module READY	D1000.0	0	ST1H-PB
Br.01	Forced output test mode	D1000.1		
Br.02	Module being changed online	D1000.2	1	ST1PSD
Br.03	Command execution	D1000.3		
Br.04	External power supply status	D1000.4	2	
Br.05		D1000.5		
Br.06	Module ready	D1000.6	3	ST1TD2
Br.07	Convert setting completed flag	D1000.7		
Br.08	Conversion completed flag	D1000.8	4	
Br.09	Alarm output signal	D1000.9		
Br.0A	—	D1000.A	—	—
to				
Br.1F	—	D1001.F	—	—

Er Error information area

Er.n Error information	Information	Master station side device	Slice No.	Module name
Er.00	Head module error information	D1002.0	0	ST1H-PB
Er.01		D1002.1		
Er.02		D1002.2	1	
Er.03		D1002.3		
Er.04	Bus refreshing module error information	D1002.4	2	ST1PSD
Er.05		D1002.5		
Er.06	CH1 error information	D1002.6	3	ST1TD2
Er.07		D1002.7		
Er.08	CH2 error information	D1002.8	4	
Er.09		D1002.9		
Er.0A	—	D1002.A	—	—
to				
Er.1F	—	D1003.F	—	—

Mr Module status area

Mr.n Module status	Information	Master station side device	Slice No.	Module name
Mr.0	Head module existence information	D1004.0	0	ST1H-PB
Mr.1		D1004.1	1	
Mr.2	Bus refreshing module existence information	D1004.2	2	ST1PSD
Mr.3	Module status	D1004.3	3	ST1TD2
Mr.4		D1004.4	4	
Mr.5	—	D1004.5	—	—
to				
Mr.15	—	D1004.F	—	—

Cr Command result area

Cr Command result area	Information	Master station side device	Slice No.	Module name
Cr.0	Cr.0(15-8) Command Execution Result, Cr.0(7-0) Start Slice No. of Execution Target	D1005	—	—
Cr.1	Executed Command No.	D1006		
Cr.2	Response Data 1	D1007		
Cr.3	Response Data 2	D1008		

[Bw] Bit output area

[Bw.n] Bit output	Information	Master station side device	Slice No.	Module name
[Bw.00]	System area (0 fixed)	D2000.0	0	ST1H-PB
[Bw.01]	System area (0 fixed)	D2000.1		
[Bw.02]	System area (0 fixed)	D2000.2	1	
[Bw.03]	Command request	D2000.3		
[Bw.04]	System area (0 fixed)	D2000.4	2	ST1PSD
[Bw.05]	System area (0 fixed)	D2000.5		
[Bw.06]	System area (0 fixed)	D2000.6	3	ST1TD2
[Bw.07]	Convert setting request	D2000.7		
[Bw.08]	System area (0 fixed)	D2000.8	4	
[Bw.09]	System area (0 fixed)	D2000.9		
[Bw.0A]	—	D2000.A	—	—
to				
[Bw.1F]	—	D2001.F	—	—

[Ew] Error clear area

[Ew.n] Error clear	Information	Master station side device	Slice No.	Module name
[Ew.00]	Error clear request	D2002.0	0	ST1H-PB
[Ew.01]	System area (0 fixed)	D2002.1		
[Ew.02]	System area (0 fixed)	D2002.2	1	
[Ew.03]	System area (0 fixed)	D2002.3		
[Ew.04]	Error clear request	D2002.4	2	ST1PSD
[Ew.05]	System area (0 fixed)	D2002.5		
[Ew.06]	Error clear request	D2002.6	3	ST1TD2
[Ew.07]	System area (0 fixed)	D2002.7		
[Ew.08]	System area (0 fixed)	D2002.8	4	
[Ew.09]	System area (0 fixed)	D2002.9		
[Ew.0A]	—	D2002.A	—	—
to				
[Ew.1F]	—	D2003.F	—	—

Sw System area

Sw System area	Information	Master station side device	Slice No.	Module name
Sw.0	System area (0 fixed)	D2004	—	—

Cw Command execution area

Cw Command execution area	Information	Master station side device	Slice No.	Module name
Cw.0	Start Slice No. of Execution Target	D2005	—	—
Cw.1	Command No. to be Executed	D2006		
Cw.2	Argument 1	D2007		
Cw.3	Argument 2	D2008		

2) Program example

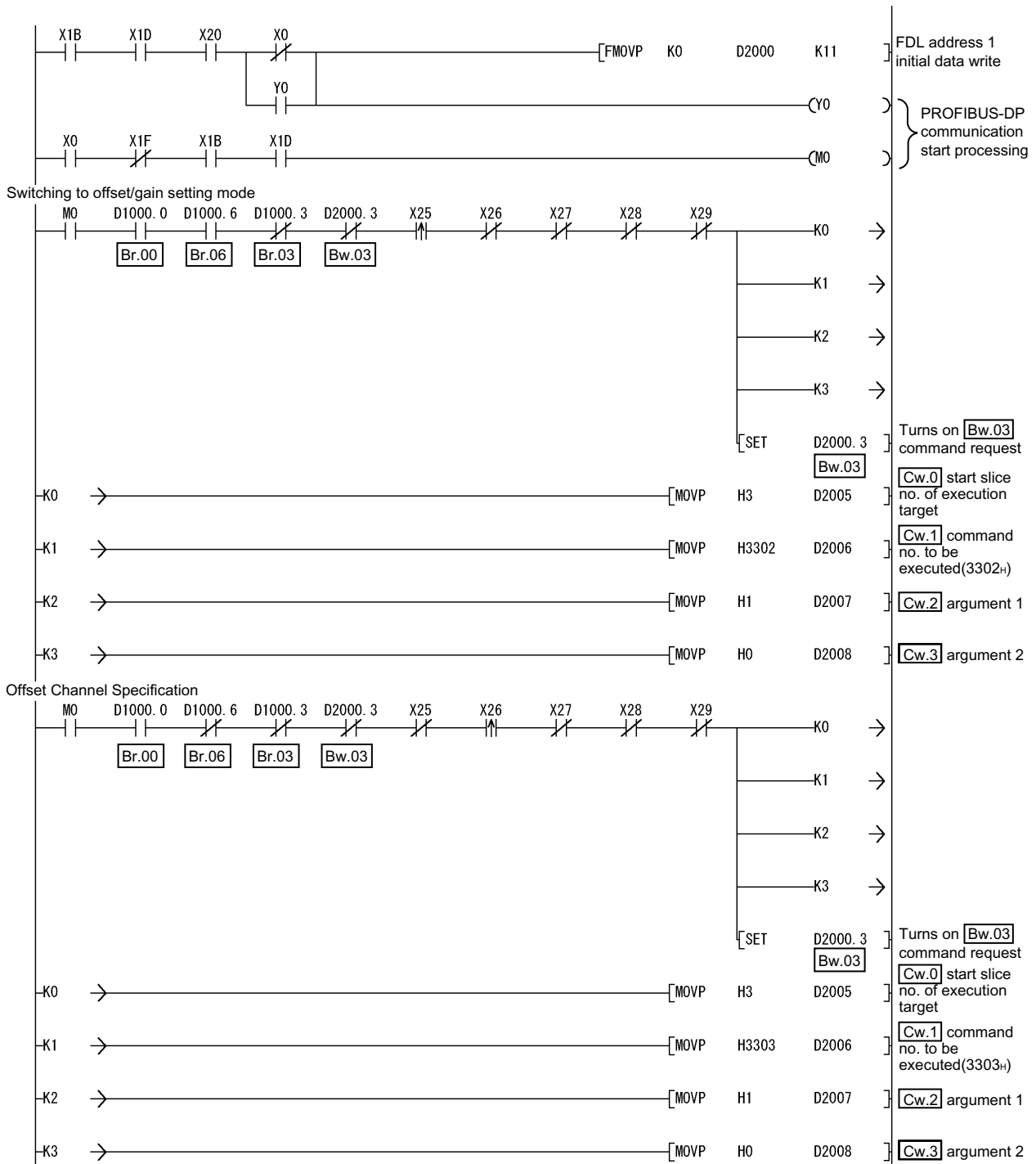

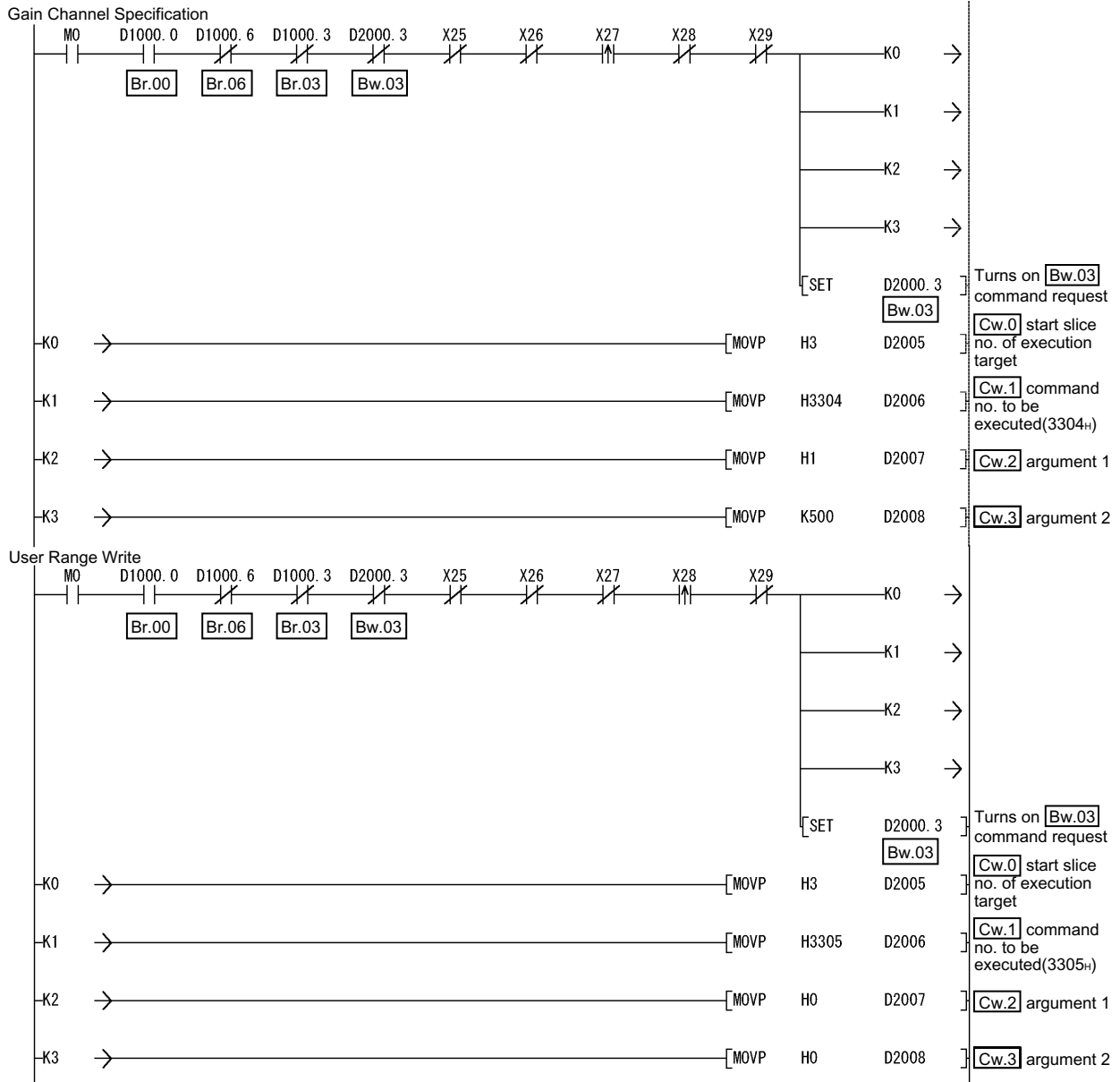

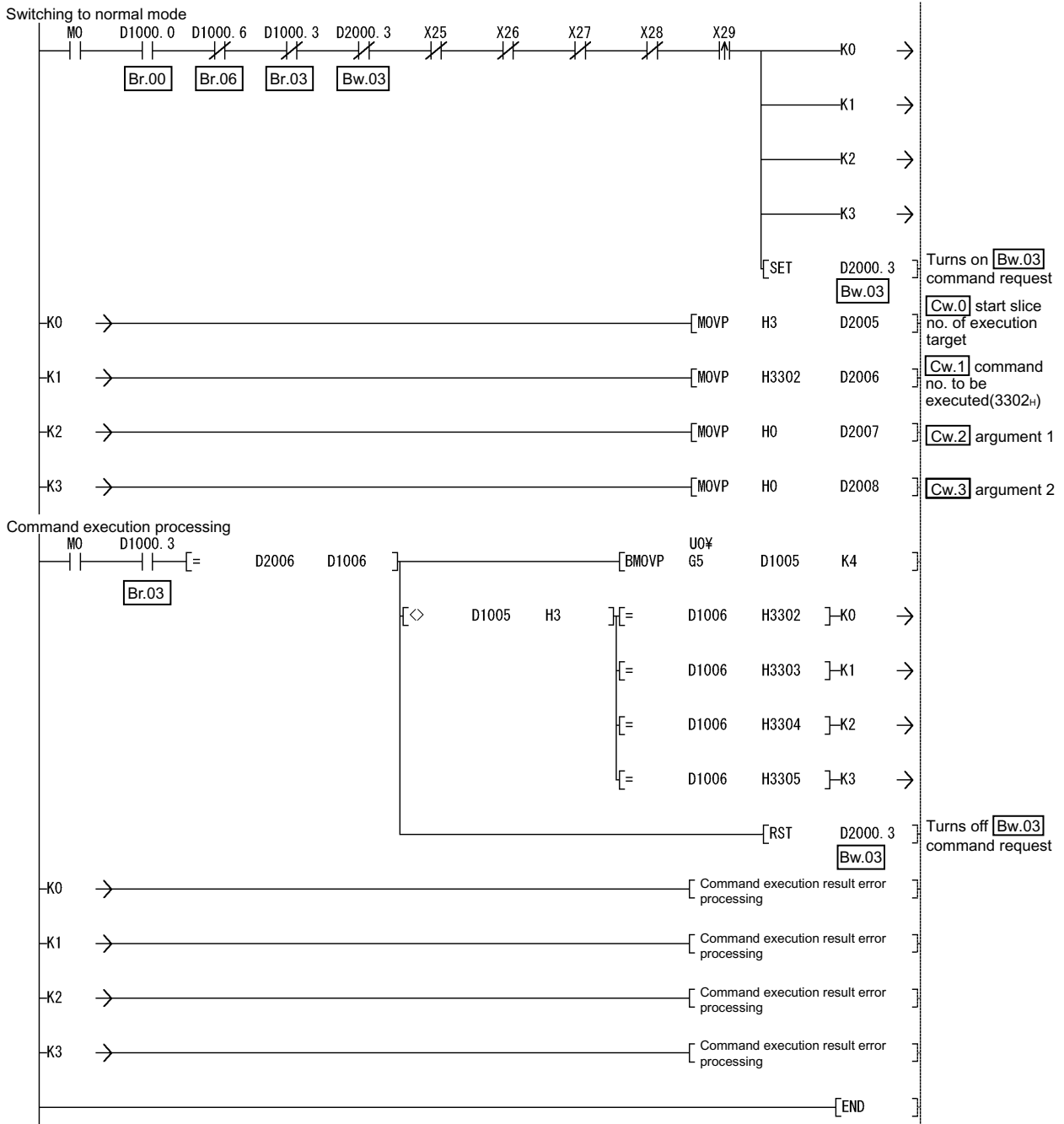

(b) When AJ71PB92D/A1SJ71PB92D is used as master station
 The program example is based on the system configuration given in
 Section 6.3.

1) Device assignment in program examples

Devices used by A1SJ71PB92D

Device	Application	Device	Application
X0	Exchange start end signal	Y0	Exchange start request signal
X0D	Watchdog timer error signal	—	
X1B	Communication READY signal		
X1D	Module READY signal		

Devices used by user

Device	Application	Device	Application
X20	PROFIBUS-DP exchange start command	M0	Refresh start request
X25	Offset/gain setting mode select signal	M225	Conversion of offset/gain setting mode select signal into pulse
X26	Offset channel specification signal	M226	Conversion of offset channel specification signal into pulse
X27	Gain channel specification signal	M227	Conversion of gain channel specification signal into pulse
X28	User range write signal	M228	Conversion of user range write signal into pulse
X29	Normal mode select signal	M229	Conversion of normal mode select signal into pulse

Devices used in I/O data

Br Bit input area

Br.n Bit input	Information	Master station side device	Slice No.	Module name
Br.00	Module READY	B0	0	
Br.01	Forced output test mode	B1		
Br.02	Module being changed online	B2	1	ST1H-PB
Br.03	Command execution	B3		
Br.04	External power supply status	B4	2	ST1PSD
Br.05		B5		
Br.06	Module ready	B6	3	ST1TD2
Br.07	Convert setting completed flag	B7		
Br.08	Conversion completed flag	B8	4	
Br.09	Alarm output signal	B9		
Br.0A	—	BA	—	—
to				
Br.1F	—	B1F	—	—

Er Error information area

Er.n Error information	Information	Master station side device	Slice No.	Module name
Er.00	Head module error information	B20	0	ST1H-PB
Er.01		B21		
Er.02		B22	1	
Er.03		B23		
Er.04	Bus refreshing module error information	B24	2	ST1PSD
Er.05		B25		
Er.06	CH1 error information	B26	3	ST1TD2
Er.07		B27		
Er.08	CH2 error information	B28	4	
Er.09		B29		
Er.0A	—	B2A	—	—
to				
Er.1F	—	B3F	—	—

Mr Module status area

Mr.n Module status	Information	Master station side device	Slice No.	Module name
Mr.0	Head module existence information	B40	0	ST1H-PB
Mr.1		B41	1	
Mr.2	Bus refreshing module existence information	B42	2	ST1PSD
Mr.3	Module status	B43	3	ST1TD2
Mr.4		B44	4	
Mr.5	—	B45	—	—
to				
Mr.15	—	B5F	—	—

Cr Command result area

Cr Command result area	Information	Master station side device	Slice No.	Module name
Cr.0	Cr.0(15-8) Command Execution Result, Cr.0(7-0) Start Slice No. of Execution Target	W0	—	—
Cr.1	Executed Command No.	W1		
Cr.2	Response Data 1	W2		
Cr.3	Response Data 2	W3		

Bw Bit output area

Bw.n Bit output	Information	Master station side device	Slice No.	Module name
Bw.00	System area (0 fixed)	B1000	0	ST1H-PB
Bw.01	System area (0 fixed)	B1001		
Bw.02	System area (0 fixed)	B1002	1	
Bw.03	Command request	B1003		
Bw.04	System area (0 fixed)	B1004	2	ST1PSD
Bw.05	System area (0 fixed)	B1005		
Bw.06	System area (0 fixed)	B1006	3	ST1TD2
Bw.07	Convert setting request	B1007		
Bw.08	System area (0 fixed)	B1008	4	
Bw.09	System area (0 fixed)	B1009		
Bw.0A	—	B100A	—	—
to				
Bw.1F	—	B101F	—	—

Ew Error clear area

Ew.n Error clear	Information	Master station side device	Slice No.	Module name
Ew.00	Error clear request	B1020	0	ST1H-PB
Ew.01	System area (0 fixed)	B1021		
Ew.02	System area (0 fixed)	B1022	1	
Ew.03	System area (0 fixed)	B1023		
Ew.04	Error clear request	B1024	2	ST1PSD
Ew.05	System area (0 fixed)	B1025		
Ew.06	Error clear request	B1026	3	ST1TD2
Ew.07	System area (0 fixed)	B1027		
Ew.08	System area (0 fixed)	B1028	4	
Ew.09	System area (0 fixed)	B1029		
Ew.0A	—	B102A	—	—
to				
Ew.1F	—	B103F	—	—

Sw System area

Sw System area	Information	Master station side device	Slice No.	Module name
Sw.0	System area (0 fixed)	B1040 to B104F	—	—

Cw Command execution area

Cw Command execution area	Information	Master station side device	Slice No.	Module name
Cw.0	Start Slice No. of Execution Target	W1000	—	—
Cw.1	Command No. to be Executed	W1001		
Cw.2	Argument 1	W1002		
Cw.3	Argument 2	W1003		

2) Program example

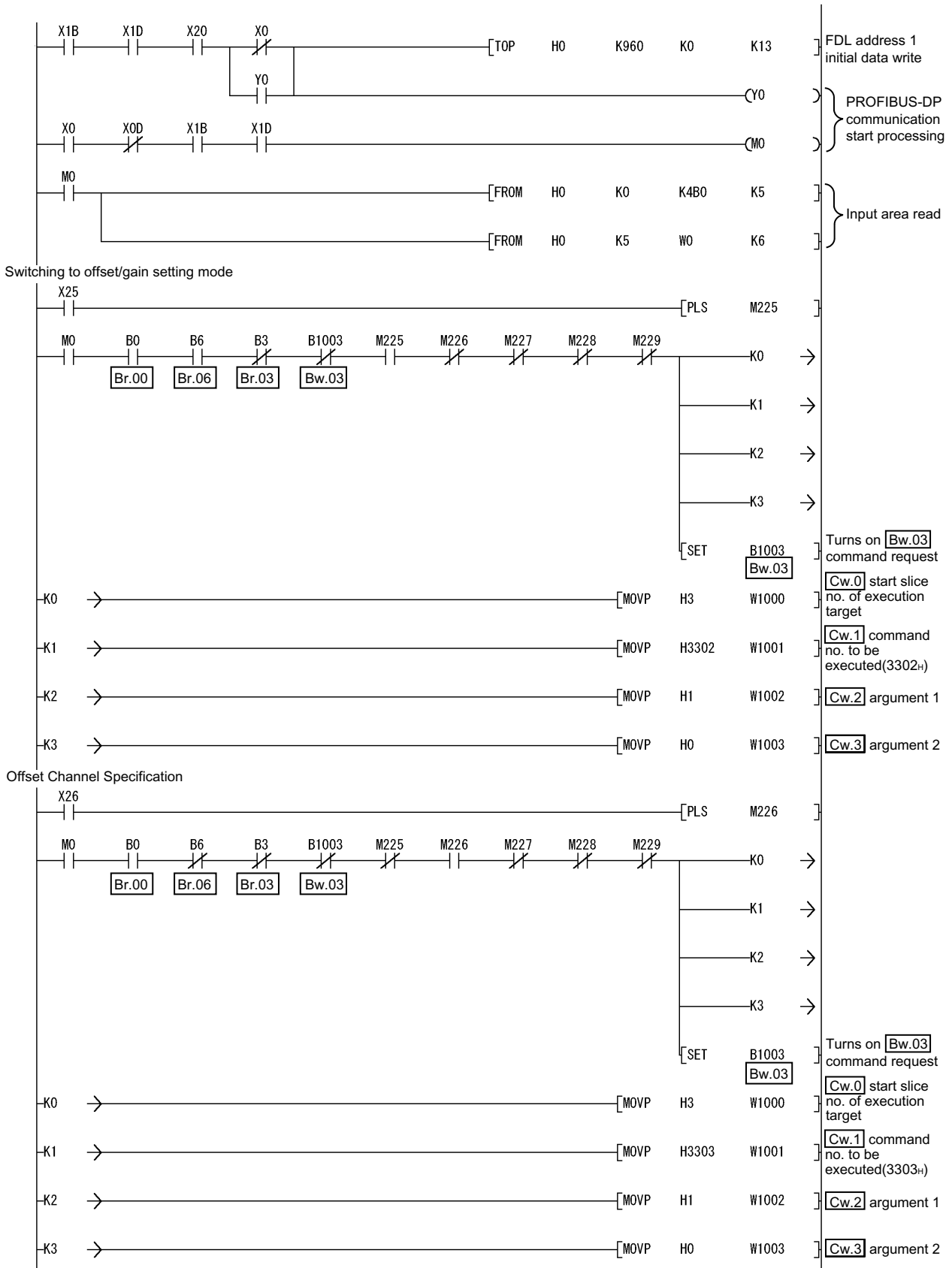

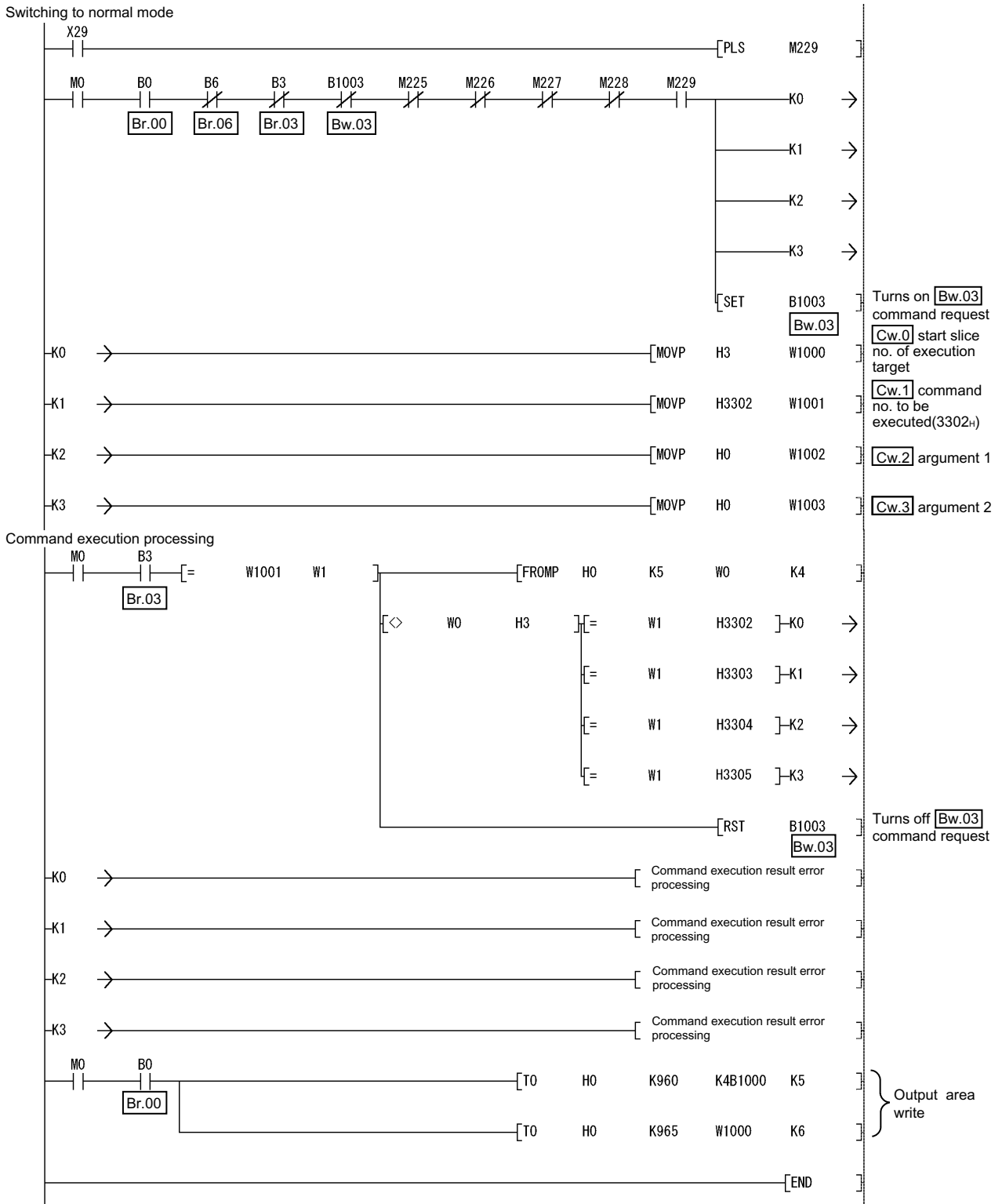

5 GX Configurator-ST

This chapter explains the functions of GX Configurator-ST used with the ST1TD2.
For details of GX Configurator-ST, refer to the GX Configurator-ST Operating Manual.

5.1 GX Configurator-ST Functions

Table 5.1 lists the GX Configurator-ST functions used with the ST1TD2.

Table 5.1 List of GX Configurator-ST Functions Used with ST1TD2

Item	Description	Reference section
Parameter Setting	(1) The following parameter items can be set on GX Configurator-ST. <ul style="list-style-type: none"> • CH□ input type setting • CH□ offset/gain value selection • CH□ cold junction compensation • CH□ conversion enable/disable setting • CH□ time/number of times specification • CH□ sampling process/averaging process setting • CH□ alarm output setting • CH□ average time/average number of times setting • CH□ upper upper limit value/upper lower limit value/lower upper limit value/lower lower limit value • CH□ sensor compensation value setting (2) Specify the area (RAM or ROM) where parameter setting will be registered. (3) Using GX Configurator-ST, parameter setting can be made while online module change is performed.	Section 5.3
Input/output monitor	(1) The I/O data of the ST1TD2 can be monitored.	Section 5.4
Forced output test	(1) Test can be conducted with the values set in the Bw bit output area or Ew error clear area of the ST1TD2.	Section 5.5
Offset/gain setting	(1) The offset and gain values of the user range can be easily set on-screen. (2) Using GX Configurator-ST, gain/offset setting can be made while online module change is performed.	Section 5.6
Online module change	(1) A module can be replaced without the system being stopped.	Chapter 7

5.2 Project Creation

When the MELSEC-ST system can be connected to a personal computer with GX Configurator-ST preinstalled, select [get system] to create a project. Even if there is no MELSEC-ST system, a project can be created. For project creation and get system, refer to the GX Configurator-ST Operating Manual.

5.3 Parameter Setting

This section explains how to set the parameters.

(1) Mode changing

The mode need not be changed.

Either the edit mode or diagnosis mode can be used for the setting.

(2) Displaying "Parameter Setting" screen

- 1) Select ST1TD2 on the "Module Information List" screen or "System Monitor" screen.
- 2) Click [Edit] → [Parameter Setting].

(3) Display/Setting Screen

Parameter Setting No. 2

Module Information

Slice No. : 3
 Module Name : ST1TD2
 Label Name :
 Base Module : ST1B-4TD2

Online

Select Data: [Select All] [Release All] Target Memory: RAM

[Upload] [Download] [Verify]

Channel: CH1 [Default] [Error Check]

Select	Item	Setting Value
<input type="checkbox"/>	Input type setting	Thermocouple K
<input type="checkbox"/>	Setting type	Thermocouple K
<input type="checkbox"/>	Offset/gain value selection	Factory default
<input type="checkbox"/>	Cold junction compensation	Enable
<input type="checkbox"/>	Conversion enable/disable setting	Enable
<input type="checkbox"/>	Time/number of times specification	Number of times
<input type="checkbox"/>	Sampling process/averaging process setting	Sampling
<input type="checkbox"/>	Alarm output setting	Disable
<input type="checkbox"/>	Average time/average number of times setting	480
<input type="checkbox"/>	Upper upper limit value	0
<input type="checkbox"/>	Upper lower limit value	0
<input type="checkbox"/>	Lower upper limit value	0
<input type="checkbox"/>	Lower lower limit value	0
<input type="checkbox"/>	Sensor compensation value setting	0

(4) Display/setting details

When setting the parameters of multiple channels, make the following setting for each channel.

(a) User parameters

Set the user parameters using the configuration software of the master station.

When the MELSEC-ST system is tested alone, set the parameters using GX Configurator-ST.

1) Input type setting

Set the input type.

Select the input type from among the following types.

Input type	Measured temperature
Thermocouple K	-270 to 1372°C
Thermocouple E	-270 to 1000°C
Thermocouple J	-210 to 1200°C
Thermocouple T	-270 to 400°C
Thermocouple B	0 to 1820°C
Thermocouple R	-50 to 1768°C
Thermocouple S	-50 to 1768°C
Thermocouple N	-270 to 1300°C
Micro voltage input	-80 to 80mV

2) Setting type

The input type setting currently valid is stored.
Setting is not allowed.

3) Offset/gain value selection

Set the factory default or user range setting.

4) Cold junction compensation

Set whether cold junction temperature compensation is enable or disable.

Disable : Cold junction temperature compensation disabled

Enable : Cold junction temperature compensation enabled

(b) Command parameters

By setting the command parameters using GX Configurator-ST, master station program steps can be reduced.

Write and save the settings, which are used for a MELSEC-ST system startup, to the ROM. (Use RAM when conducting a test temporarily.)

1) Conversion enable/disable setting

Set whether conversion is enabled or disabled.

Disable : Conversion disabled

Enable : Conversion enabled

2) Time/number of times specification

Specify the time/number of times when the averaging processing is selected.

3) Sampling process/averaging process setting

Specify the sampling processing or averaging processing.

4) Alarm output setting

Set whether alarm output processing is performed or not.

Disable : Alarm output processing not performed

Enable : Alarm output processing performed

5) Average time/average number of times setting

Set the average time or average number of times.

Their setting ranges are indicated below.

Average number of times : 4 to 500 times

Average time : 480 to 5000ms

6) Upper upper limit value/Upper lower limit value/Lower upper limit value/Lower lower limit value

Set the upper upper limit value, upper lower limit value, lower upper limit value and lower lower limit value of the alarm output.

Setting range on each input type is shown below.

In the case of thermocouple input, set the value in units of 0.1°C.

[Example] To set to 0.3°C Enter "3".

Input type	Setting range (Accuracy guarantee range)
Thermocouple K	-2700 to 13720 (-2000 to 12000)
Thermocouple E	-2700 to 10000 (-2000 to 9000)
Thermocouple J	-2100 to 12000 (-400 to 7500)
Thermocouple T	-2700 to 4000 (-2000 to 3500)
Thermocouple B	0 to 18200 (6000 to 17000)
Thermocouple R	-500 to 17680 (0 to 16000)
Thermocouple S	-500 to 17680 (0 to 16000)
Thermocouple N	-2700 to 13000 (-2000 to 12500)
Micro voltage input	-21000 to 21000 (-20000 to 20000)

7) Sensor compensation value setting

Set the sensor compensation value.

The setting range of the sensor compensation value is -500 to 500.

In the case of thermocouple input, set the value in units of 0.1°C.

[Example] To set to 0.3°C Enter "3".

The setting for the micro voltage input is performed in increments of 4μV/digit.

[Example] When the micro voltage conversion value is 10003 at 40mV input Enter "-3".

(5) Parameter writing

- 1) From the "Channel:" pull-down menu, select the channel where the parameters will be set.
- 2) Select the parameter items to be written to the ST1TD2 by checking the corresponding "select" check box.
- 3) Make setting in the "Setting Value" field.
- 4) Select the target memory (RAM or ROM) from the pull-down menu of "Target Memory".
- 5) Click the button.

When writing the parameters of multiple channels to the ST1TD2, perform the operations in steps 1) to 5) for each channel.

5.4 Input/Output Monitor

This section explains how to monitor the I/O data of the ST1TD2.

- (1) Mode changing
Click [Mode] → [Diagnosis].
- (2) Displaying "Input/Output Monitor" screen
 - 1) Select ST1TD2 on the "System Monitor" screen.
 - 2) Click the **Input/Output Monitor** button.
Monitor starts as soon as the "Input/Output Monitor" screen is displayed.
- (3) Display/Setting Screen

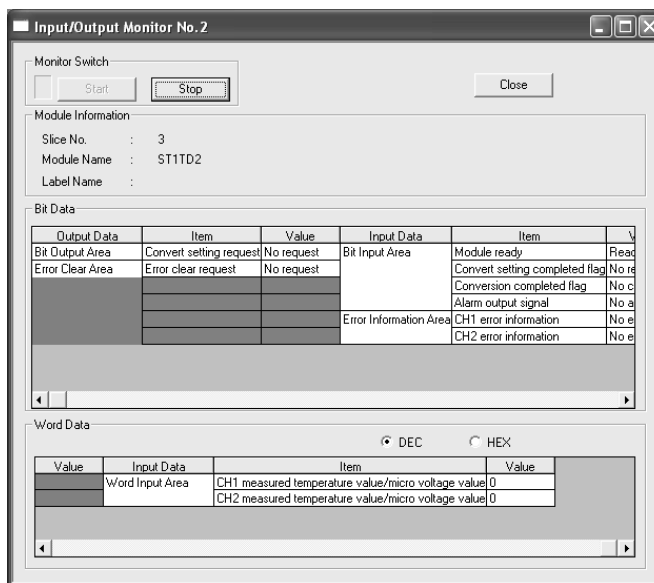

- (4) Display/setting details
 - (a) Bit Data

Input/Output Data	Item	Description
Bit Output Area	Convert setting request	The status of [Bw.n+1] Convert setting request is displayed.
Error Clear Area	Error clear request	The status of [Ew.n] Error clear request is displayed.
Bit Input Area	Module ready	The status of [Br.n] Module ready is displayed.
	Convert setting completed flag	The status of [Br.n+1] Convert setting completed flag is displayed.
	Conversion completed flag	The status of [Br.n+2] Conversion completed flag is displayed.
	Alarm output signal	The status of [Br.n+3] Alarm output signal is displayed.
Error Information Area	CH□ error information	The status of [Er.n+3] to [Er.n] CH□ error information is displayed.

- (b) Word Data

The display format (decimal/hexadecimal) can be changed.

Input/Output Data	Item	Description
Word Input Area	CH□ measured temperature value/micro voltage value	The value of [Wr.n] , [Wr.n+1] CH□ measured temperature value/micro voltage value is displayed.

5.5 Forced Output Test

This section explains a forced output test.
 Conduct the test after setting values to the bit output area or error clear area of the ST1TD2.

- (1) Mode changing
 Click [Mode] → [Diagnosis].
- (2) Displaying "Forced Output Test" screen
 1) Select ST1TD2 on the "System Monitor" screen.
 2) Click the **Forced Output Test** button.
- (3) Display/Setting Screen

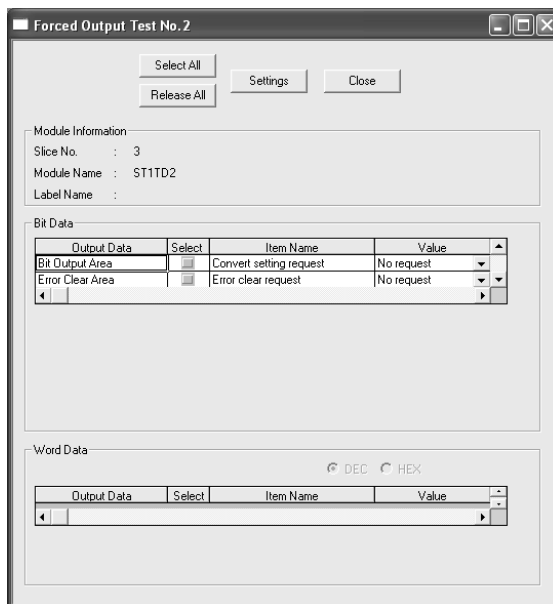

- (4) Display/setting details
 (a) Bit Data

Output Data	Item	Description
Bit Output Area	Convert setting request	The setting of Bw.n+1 Convert setting request can be changed.
Error Clear Area	Error clear request	The setting of Ew.n Error clear request can be changed.

- (b) Word Data
 Unavailable for the ST1TD2.

(5) Test operation

- 1) Select the test item by checking the corresponding "Select" check box.
- 2) Make setting in the "Value" field.
- 3) Click the button.*

Clicking the button executes the test.

*: When the module is not in the forced output test mode, a screen asking whether to switch to the forced output test mode. Click the button to switch to the forced output test mode.

When the module is switched to the forced output test mode, the RUN LED of the head module flashes.

POINT

When the forced output test mode has been cancelled, make sure that the RUN LED of the head module is on.

5.6 Offset/Gain Setting

This section explains how to make offset/gain setting.

(1) Input type setting

Set the input type for the offset/gain setting on the parameter setting screen.
For the parameter setting, refer to Section 5.3.

(2) Mode changing

Click [Mode] → [Diagnosis].

(3) Displaying "Offset/Gain Setting" screen

1) Select ST1TD2 on the "System Monitor" screen.

2) Click the **Offset/Gain Setting** button.*

*: When the module is not in the forced output test mode, a screen appears asking whether to switch to the forced output test mode. Click the **OK** button to switch to the forced output test mode.

When the module is switched to the forced output test mode, the RUN LED of the head module flashes.

3) As a screen appears asking whether to switch to the offset/gain setting mode, click the **OK** button to switch to the offset/gain setting mode.

After switched to the offset/gain setting mode, the RUN LED of ST1TD2 flashes (0.5s interval) and the ST1TD2 stops.

(4) Display/Setting Screen

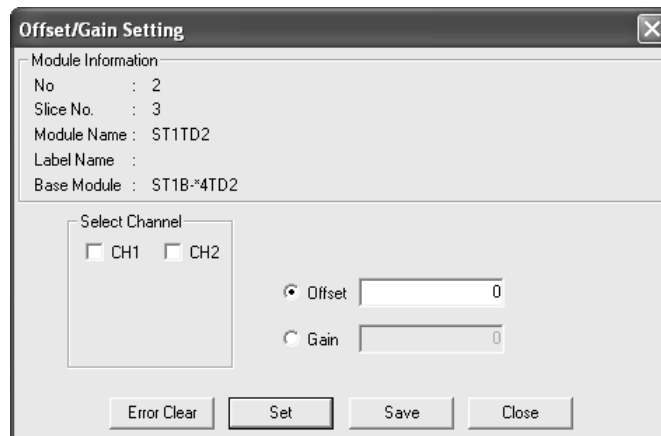

(5) Offset/gain setting

When setting different offset and gain values for different channels, perform the operations in (a), (b) for each channel.

Since the operation in (c) is to be done to write the offset/gain settings of all channels to the ST1TD2, perform it only once at the last.

(a) Offset value setting operation

- 1) Select the channel where the offset value will be set by checking the corresponding "Select channel" check box.

By checking multiple check boxes, values can be set to multiple channels at the same time.

- 2) Specify "Offset".

- 3) Enter a value as an offset value to the channel to be adjusted, set a temperature setting value or voltage setting value which suits to input, and then click the button.

- The setting for the temperature setting value is performed in units of 0.1°C.

[Example] To set to 0.3°C Enter "3".

- The setting for the voltage setting value is performed in units of 0.01mV.

[Example] To set to 3mV Enter "300".

Setting range on each input type is shown below.

Input type	Setting range (Accuracy guarantee range)
Thermocouple K	-2700 to 13720 (-2000 to 12000)
Thermocouple E	-2700 to 10000 (-2000 to 9000)
Thermocouple J	-2100 to 12000 (-400 to 7500)
Thermocouple T	-2700 to 4000 (-2000 to 3500)
Thermocouple B	0 to 18200 (6000 to 17000)
Thermocouple R	-500 to 17680 (0 to 16000)
Thermocouple S	-500 to 17680 (0 to 16000)
Thermocouple N	-2700 to 13000 (-2000 to 12500)
Micro voltage input	-8000 to 8000 (-8000 to 8000)

(b) Gain value setting

- 1) Select the channel where the gain value will be set by checking the corresponding "Select channel" check box.

By checking multiple check boxes, values can be set to multiple channels at the same time.

- 2) Specify "Gain".

- 3) Enter a value as a gain value to the channel to be adjusted, set a temperature setting value or voltage setting value which suits to input, and then click the **Set** button.

- The setting for the temperature setting value is performed in units of 0.1°C.

[Example] To set to 0.3°CEnter "3".

- The setting for the voltage setting value is performed in units of 0.01mV.

[Example] To set to 3mV Enter "300".

Setting range on each input type is shown below.

Input type	Setting range (Accuracy guarantee range)
Thermocouple K	-2700 to 13720 (-2000 to 12000)
Thermocouple E	-2700 to 10000 (-2000 to 9000)
Thermocouple J	-2100 to 12000 (-400 to 7500)
Thermocouple T	-2700 to 4000 (-2000 to 3500)
Thermocouple B	0 to 18200 (6000 to 17000)
Thermocouple R	-500 to 17680 (0 to 16000)
Thermocouple S	-500 to 17680 (0 to 16000)
Thermocouple N	-2700 to 13000 (-2000 to 12500)
Micro voltage input	-8000 to 8000 (-8000 to 8000)

(c) Offset/gain setting writing

Click the **Save** button.

The offset/gain settings for all channels are written to the ST1TD2.

POINT
<p>(1) Clicking the Save button in the following condition generates errors. For details of error codes, refer to Section 9.1.</p> <ul style="list-style-type: none"> • Offset value \geq Gain value (Error code : 400 □H) • (Gain value) - (Offset value) \leq 0.2[°C] (for temperature input) (Error code : 410 □H) • (Gain value) - (Offset value) \leq 20[μV] (for micro voltage input) (Error code : 410 □H) <p>In this case, click the Error Clear button to clear the error, and make setting again.</p>
<p>(2) When the offset/gain setting screen is closed, the screen displays a message that asks if you are sure to change to the normal mode. Click the OK button to change to the normal mode. When the module is put in the normal mode, the RUN LED of the ST1TD2 turns on.</p>
<p>(3) When the forced output test mode has been released, make sure that the RUN LED of the head module is on.</p>

6 PROGRAMMING

This chapter explains program examples available when the QJ71PB92D and AJ71PB92D/A2SJ71PB92D are used as the master station.

REMARK

Refer to the following manuals for details of the QJ71PB92D and AJ71PB92D/A1SJ71PB92D.

<QJ71PB92D>

- PROFIBUS-DP Interface Module User's Manual
- SH-080127 (13JR22)

<AJ71PB92D/A1SJ71PB92D>

- PROFIBUS-DP Interface Module type AJ71PB92D/A1SJ71PB92D User's Manual
- IB-66773 (13JL20)

6.1 Programming Procedure

In the following procedure, create a program enabling execution of the temperature conversion or micro voltage conversion in the ST1TD2.

When utilizing the program example introduced in this chapter for an actual system, fully verify that there are no problems in controllability in the target system.

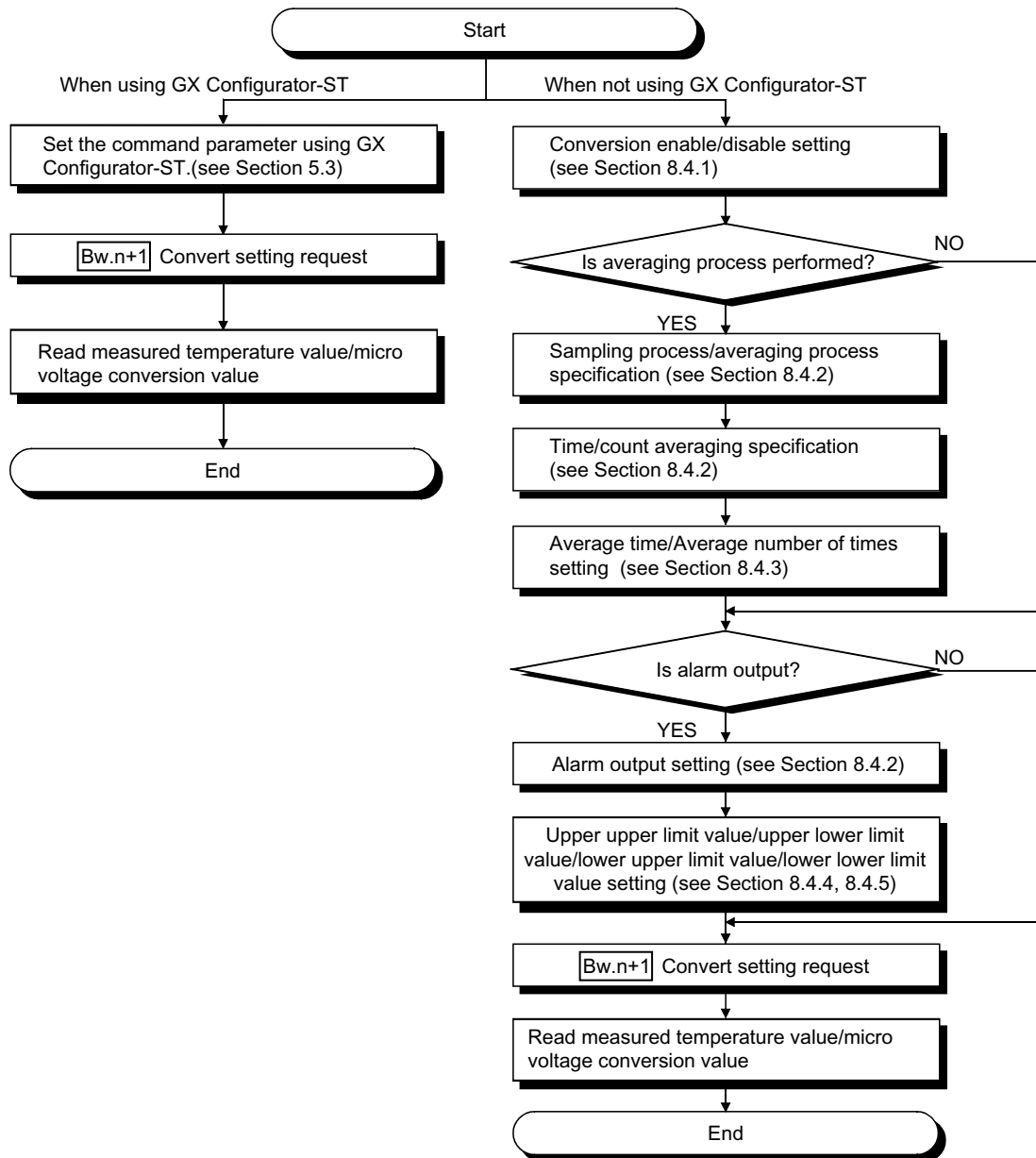

POINT

(1) While a command is being executed, other command is not executable.

Also, a command can be executed for only one module.

When executing the same command for multiple modules or executing several kinds of commands, provide an interlock in the program using

Br.03 Command execution and **Bw.03** Command request as shown below.

<Example>

Executing 2 commands (Commands 1 and 2) consecutively

- 1) Confirm that **Br.03** Command execution and **Bw.03** Command request are off. (Interlock for other commands)
 - 2) Write the command information of Command 1 to **Cw** Command execution area.
 - 3) Turn on **Bw.03** Command request.
 - 4) After **Br.03** Command execution turns on, read the result of Command 1 from **Cr** Command result area.
 - 5) Turn off **Bw.03** Command request.
-
- 6) Confirm that **Br.03** Command execution and **Bw.03** Command request are off. (Interlock for other commands)
 - 7) Write the command information of Command 2 to **Cw** Command execution area.
 - 8) Turn on **Bw.03** Command request.
 - 9) After **Br.03** Command execution turns on, read the result of Command 2 from **Cr** Command result area.
 - 10) Turn off **Bw.03** Command request.

Processing of
Command 1

Processing of
Command 2

If a command is executed without any interlock, the following status will be generated.

- 1) When turning off **Bw.03** Command request before completion of the command:
 - **Br.03** Command execution does not turn on.
 - The command result is not stored in **Cr** Command result area.
 - The command requested once may be executed.
- 2) When executing a command inadvertently during execution of other command:
The command is executed based on the information written in **Cw** Command execution area at the time that **Bw.03** Command request turns on.

(2) Performing online module change may require a previous arrangement, depending on the use condition.

For details, refer to Section 7.2.

6.2 When QJ71PB92D is Used as Master Station

This section explains program examples available when the QJ71PB92D is used as the master station.

Section 6.2.1 uses the following system configuration example for explanation.

(1) System configuration of master station (QJ71PB92D)

The system configuration of the master station (QJ71PB92D) used in this section is shown below.

(a) System configuration of master station (QJ71PB92D)

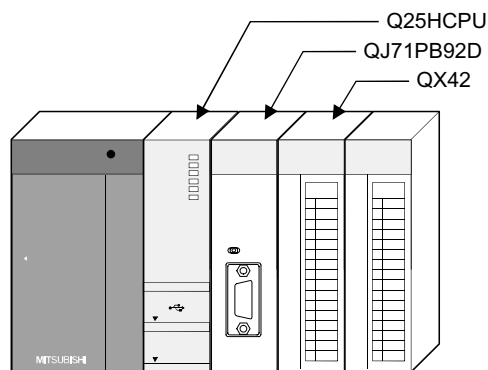

(b) Settings of master station (QJ71PB92D)

Item		Setting
I/O signals		X/Y000 to X/Y01F
Operation mode		Extended service mode (MODE E)
I/O data area (buffer memory) for FDL address 1 (MELSEC-ST system)	Input data	0(0 _H) to 10(0A _H)
	Output data	960(3C0 _H) to 970(3CA _H)

REMARK

The MELSEC-ST system varies in I/O data size depending on the maximum input/output point settings and the number of mounted intelligent function modules. Hence, the master station's operation mode is set to the extended service mode (MODE E) where the data size is variable.

(2) System configuration of MELSEC-ST system

The following system configuration is used as the MELSEC-ST system for explanation.

(a) System configuration of slave station (MELSEC-ST system)

- 1) FDL address: 1
- 2) Maximum I/O point setting: 32-point mode

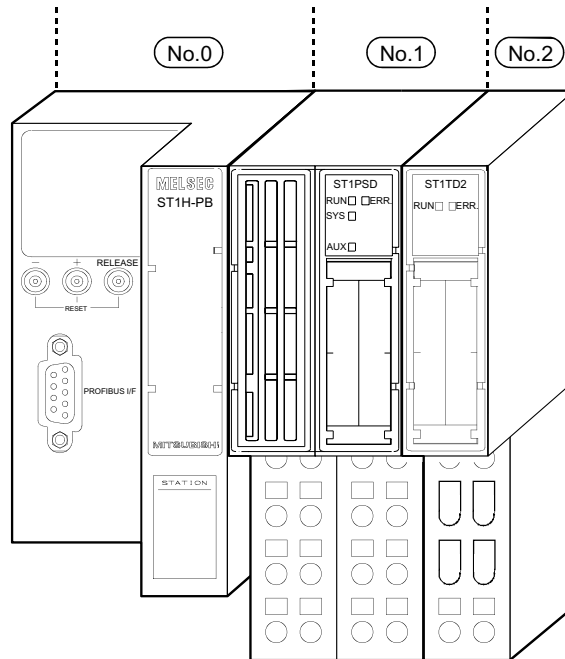

The following table uses the maximum input/output points setting sheet given in the Head Module User's Manual.

No.	Module Name	Number of Occupied I/O Points	Start Slice No. (Number of occupied slices)	Wr.n	Ww.n	5V DC Internal Current Consumption (Total)	24V DC Current (Total)	System Length (Total)
0	ST1H-PB	4	0(2)	—	—	0.530A(0.530A)	0A(0A)	—
1	ST1PSD	2	2(1)	—	—	—	—	25.2mm(25.2mm)
2	ST1TD2	4	3(2)	2	2	0.080A(0.610A)	*1	12.6mm(37.8mm)
Total		10	—	2	2	—	—	—

*1: The 24V DC current changes depending on the external device connected to each slice module. Confirm the current consumption of the external device connected to each slice module, and calculate the total value. Refer to the MELSEC-ST System User's Manual for details of current consumption calculation.

(b) GX Configurator-DP setting

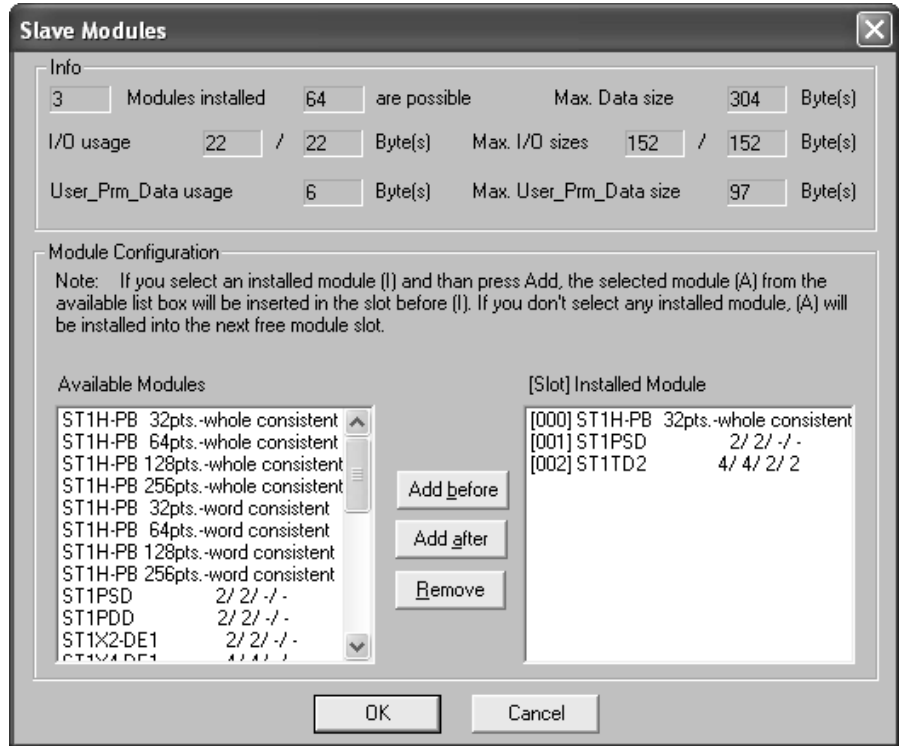

(c) ST1TD2 setting

The input type is set by GX Configurator-DP.

- Conversion-enabled channel..... CH1, CH2
- CH1 Input type setting Thermocouple K
- CH2 Input type setting Micro voltage input
- Sampling process channel CH2
- Count-based averaging process channel
..... CH1 (average number of times: 50)
- Alarm output channel
..... CH1 (upper upper limit value, upper lower limit value: 2000)
(lower upper limit value, lower lower limit value: 0)
- Sensor compensation channel..... CH2 (compensation value: 2)

(3) I/O data assignment

The following shows the I/O data assignment result in the system configuration example given in (2) in this section.

(a) Input data

Buffer memory address
Decimal
(Hexadecimal) b15

	b8				b7				b0											
0 (0H)	Br.0F	Br.0E	Br.0D	Br.0C	Br.0B	Br.0A	Br.09	Br.08	Br.07	Br.06	Br.05	Br.04	Br.03	Br.02	Br.01	Br.00	} Br Bit input area			
	0				No.2				No.1				No.0							
1 (1H)	Br.1F	Br.1E	Br.1D	Br.1C	Br.1B	Br.1A	Br.19	Br.18	Br.17	Br.16	Br.15	Br.14	Br.13	Br.12	Br.11	Br.10	} Br Bit input area			
	0																			
2 (2H)	Er.0F	Er.0E	Er.0D	Er.0C	Er.0B	Er.0A	Er.09	Er.08	Er.07	Er.06	Er.05	Er.04	Er.03	Er.02	Er.01	Er.00	} Er Error information area			
	0				No.2				No.1				No.0							
3 (3H)	Er.1F	Er.1E	Er.1D	Er.1C	Er.1B	Er.1A	Er.19	Er.18	Er.17	Er.16	Er.15	Er.14	Er.13	Er.12	Er.11	Er.10	} Er Error information area			
	0																			
4 (4H)	Mr.15	Mr.14	Mr.13	Mr.12	Mr.11	Mr.10	Mr.9	Mr.8	Mr.7	Mr.6	Mr.5	Mr.4	Mr.3	Mr.2	Mr.1	Mr.0	} Mr Module status area			
	0								No.2				No.1					No.0		
5 (5H)	Cr.0(15-8) Command execution result								Cr.0(7-0) Start slice No. of execution target								} Cr Command result area			
6 (6H)	Cr.1 Executed command No.																			
7 (7H)	Cr.2 Response data 1																			
8 (8H)	Cr.3 Response data 2																			
9 (9H)	Wr.00 CH1 measured temperature value/micro voltage conversion value (Wr.n)																} Wr Word input area			
10 (AH)	Wr.01 CH2 measured temperature value/micro voltage conversion value (Wr.n+1)																			

No. 0: Head module (ST1H-PB)
No. 1: Bus refreshing module (ST1PSD)
No. 2: Intelligent Function Module (ST1TD2)

(b) Output data

Buffer memory address
Decimal
(Hexadecimal) b15

	b8				b7				b0								
960(3C0H)	Bw.0F	Bw.0E	Bw.0D	Bw.0C	Bw.0B	Bw.0A	Bw.09	Bw.08	Bw.07	Bw.06	Bw.05	Bw.04	Bw.03	Bw.02	Bw.01	Bw.00	} Bw Bit output area
	0				No.2				No.1				No.0				
961(3C1H)	Bw.1F	Bw.1E	Bw.1D	Bw.1C	Bw.1B	Bw.1A	Bw.19	Bw.18	Bw.17	Bw.16	Bw.15	Bw.14	Bw.13	Bw.12	Bw.11	Bw.10	} Bw Bit output area
	0																
962(3C2H)	Ew.0F	Ew.0E	Ew.0D	Ew.0C	Ew.0B	Ew.0A	Ew.09	Ew.08	Ew.07	Ew.06	Ew.05	Ew.04	Ew.03	Ew.02	Ew.01	Ew.00	} Ew Error clear area
	0				No.2				No.1				No.0				
963(3C3H)	Ew.1F	Ew.1E	Ew.1D	Ew.1C	Ew.1B	Ew.1A	Ew.19	Ew.18	Ew.17	Ew.16	Ew.15	Ew.14	Ew.13	Ew.12	Ew.11	Ew.10	} Ew Error clear area
	0																
964(3C4H)	Sw.0 System Area																} Sw System Area
965(3C5H)	Cw.0 Start Slice No. of Execution Target																
966(3C6H)	Cw.1 Command No. to be Executed																} Cw Command execution area
967(3C7H)	Cw.2 Argument 1																
968(3C8H)	Cw.3 Argument 2																
969(3C9H)	Ww.00 System Area (Ww.n)																} Ww Word output area
970(3CAH)	Ww.01 System Area (Ww.n+1)																

No.0: Head Module(ST1H-PB)
No.1: Bus refreshing module (ST1PSD)
No.2: Intelligent Function Module (ST1TD2)

(4) Device assignment in program examples

The program example in this section uses the following device assignment.

(a) Devices used by QJ71PB92D

Device	Application	Device	Application
X0	Exchange start end signal	Y0	Exchange start request signal
X1B	Communication READY signal	—	—
X1D	Module READY signal		
X1F	Watchdog timer error signal		

(b) Devices used by user

Device	Application	Device	Application
X20	PROFIBUS-DP exchange start command	M0	Refresh start request
X30	ST1TD2 error code read request	M1	CH1 conversion completed signal
X31	ST1TD2 error clear request	M2	CH2 conversion completed signal
D500	CH1 measured temperature value read destination	M100	Command execution signal
D501	CH2 micro voltage conversion value read destination	M200	Operation condition set value write signal
D600, D601	ST1TD2 error code read destination	M201	Average time/average number of times set value write signal
—	—	M202	CH1 upper upper/upper lower limit set value write signal
		M203	CH1 lower upper/lower lower limit set value write signal
		M204	Conversion enable/disable setting write signal
		M205	Sensor compensation value write signal
		M206	Conversion completed channel read signal
		M210	Conversion start signal
		M230	ST1TD2 error clear request signal

(c) Devices used in I/O data

1) **Br** Bit input area

Br.n Bit input	Information	Master station side device	Slice No.	Module name
Br.00	Module READY	D1000.0	0	ST1H-PB
Br.01	Forced output test mode	D1000.1		
Br.02	Module being changed online	D1000.2	1	ST1H-PB
Br.03	Command execution	D1000.3		
Br.04	External power supply status	D1000.4	2	ST1PSD
Br.05		D1000.5		
Br.06	Module ready	D1000.6	3	ST1TD2
Br.07	Convert setting completed flag	D1000.7		
Br.08	Conversion completed flag	D1000.8	4	ST1TD2
Br.09	Alarm output signal	D1000.9		
Br.0A	—	D1000.A	—	—
to				
Br.1F	—	D1001.F	—	—

2) **Er** Error information area

Er.n Error information	Information	Master station side device	Slice No.	Module name
Er.00	Head module error information	D1002.0	0	ST1H-PB
Er.01		D1002.1		
Er.02		D1002.2	1	
Er.03		D1002.3		
Er.04	Bus refreshing module error information	D1002.4	2	ST1PSD
Er.05		D1002.5		
Er.06	CH1 error information	D1002.6	3	ST1TD2
Er.07		D1002.7		
Er.08	CH2 error information	D1002.8	4	
Er.09		D1002.9		
Er.0A	—	D1002.A	—	—
to				
Er.1F	—	D1003.F	—	—

3) **Mr** Module status area

Mr.n Module status	Information	Master station side device	Slice No.	Module name
Mr.0	Head module existence information	D1004.0	0	ST1H-PB
Mr.1		D1004.1	1	
Mr.2	Bus refreshing module existence information	D1004.2	2	ST1PSD
Mr.3	Module status	D1004.3	3	ST1TD2
Mr.4		D1004.4	4	
Mr.5	—	D1004.5	—	—
to				
Mr.15	—	D1004.F	—	—

4) **Cr** Command result area

Cr Command result area	Information	Master station side device	Slice No.	Module name
Cr.0	Cr.0(15-8) Command Execution Result, Cr.0(7-0) Start Slice No. of Execution Target	D1005	—	—
Cr.1	Executed Command No.			
Cr.2	Response Data 1			
Cr.3	Response Data 2			

5) **Wr** Word input area

Wr.n Word input	Information	Master station side device	Slice No.	Module name
Wr.00	CH1 measured temperature value/micro voltage conversion value (Wr.n)	D1009	3	ST1TD2
Wr.01	CH2 measured temperature value/micro voltage conversion value (Wr.n+1)	D1010		

6) **Bw** Bit output area

Bw.n Bit output	Information	Master station side device	Slice No.	Module name
Bw.00	System area (0 fixed)	D2000.0	0	ST1H-PB
Bw.01	System area (0 fixed)	D2000.1		
Bw.02	System area (0 fixed)	D2000.2		
Bw.03	Command request	D2000.3	1	
Bw.04	System area (0 fixed)	D2000.4	2	ST1PSD
Bw.05	System area (0 fixed)	D2000.5		
Bw.06	System area (0 fixed)	D2000.6	3	ST1TD2
Bw.07	Convert setting request	D2000.7		
Bw.08	System area (0 fixed)	D2000.8	4	
Bw.09	System area (0 fixed)	D2000.9		
Bw.0A	—	D2000.A	—	—
to				
Bw.1F	—	D2001.F	—	—

7) **Ew** Error clear area

Ew.n Error clear	Information	Master station side device	Slice No.	Module name
Ew.00	Error clear request	D2002.0	0	ST1H-PB
Ew.01	System area (0 fixed)	D2002.1		
Ew.02	System area (0 fixed)	D2002.2		
Ew.03	System area (0 fixed)	D2002.3	1	
Ew.04	Error clear request	D2002.4	2	ST1PSD
Ew.05	System area (0 fixed)	D2002.5		
Ew.06	Error clear request	D2002.6	3	ST1TD2
Ew.07	System area (0 fixed)	D2002.7		
Ew.08	System area (0 fixed)	D2002.8	4	
Ew.09	System area (0 fixed)	D2002.9		
Ew.0A	—	D2002.A	—	—
to				
Ew.1F	—	D2003.F	—	—

8) **Sw** System area

Sw System area	Information	Master station side device	Slice No.	Module name
Sw.0	System area (0 fixed)	D2004	—	—

9) **Cw** Command execution area

Cw Command execution area	Information	Master station side device	Slice No.	Module name
Cw.0	Start Slice No. of Execution Target	D2005	—	—
Cw.1	Command No. to be Executed	D2006		
Cw.2	Argument 1	D2007		
Cw.3	Argument 2	D2008		

10) **Ww** Word output area

Ww Word output	Information	Master station side device	Slice No.	Module name
Ww.00	System area (0 fixed) (Ww.n)	D2009	3	ST1TD2
Ww.01	System area (0 fixed) (Ww.n+1)	D2010		

6.2.1 Program example available when using auto refresh in QJ71PB92D

This section explains a program example available when auto refresh is used in the QJ71PB92D to communicate with the MELSEC-ST system.

The program example in this section is based on the system configuration in Section 6.2.

(1) Auto refresh setting

To use auto refresh, setting must be made on GX Configurator-DP.

Refer to the GX Configurator-DP Manual for details.

The screenshot shows the 'Slave Parameter Settings' dialog box. The 'Model' is 'ST1H-PB' and the 'Vendor' is 'MITSUBISHI ELECTRIC CORPORATION'. Under 'Slave Properties', the 'Name' is 'Slave_Nr_001', 'FDL Address' is '1', 'Watchdog' is checked with a time of '5' (x 10 ms), and 'min T_sdr' is '11'. There are checkboxes for 'Group identification number' (Grp 1-8), 'Active', 'Sync (Output)', and 'Freeze (Input)'. The 'Addresses in MELSEC CPU Memory' section shows 'Input CPU Device' as 'D' with address '1000' to '1010', and 'Output CPU Device' as 'D' with address '2000' to '2010'. A 'Swap I/O Bytes in Master' checkbox is also present. Buttons at the bottom include 'OK', 'Cancel', 'Default', 'User Param.', and 'Select Modules'.

(2) Programming example

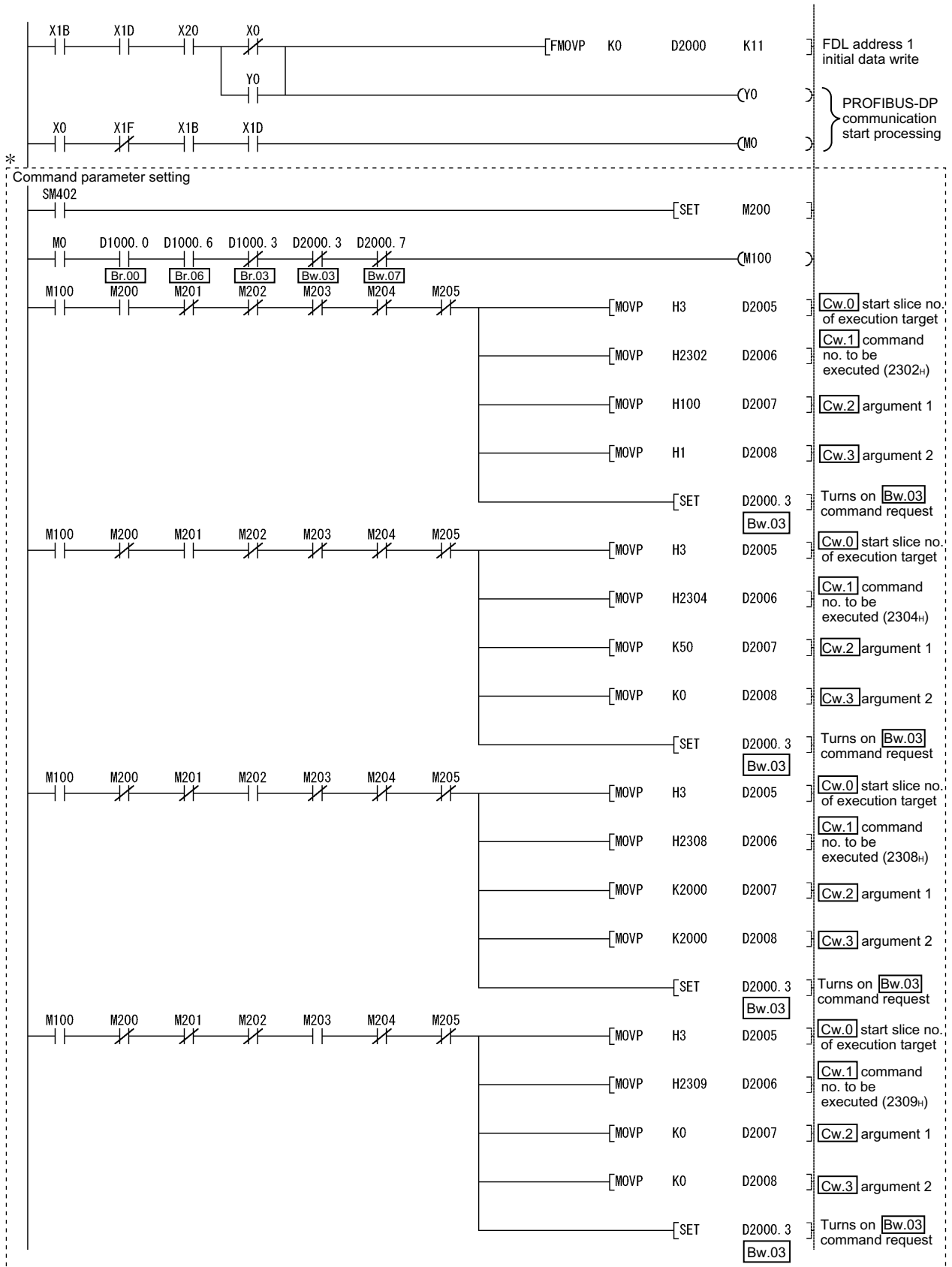

* The program area enclosed by the dotted line is not required when GX Configurator-ST is used to set the command parameters.

*

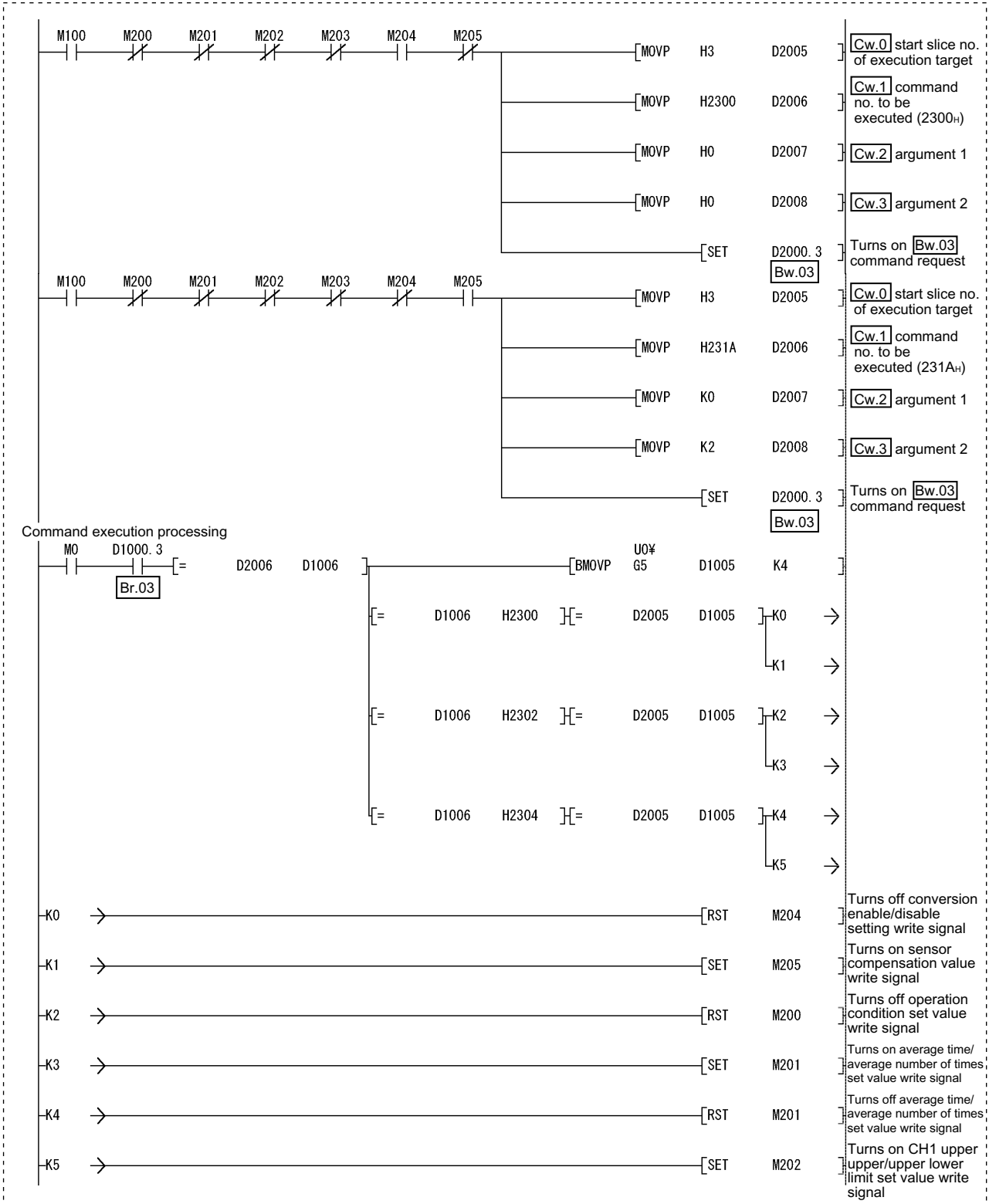

* The program area enclosed by the dotted line is not required when GX Configurator-ST is used to set the command parameters.

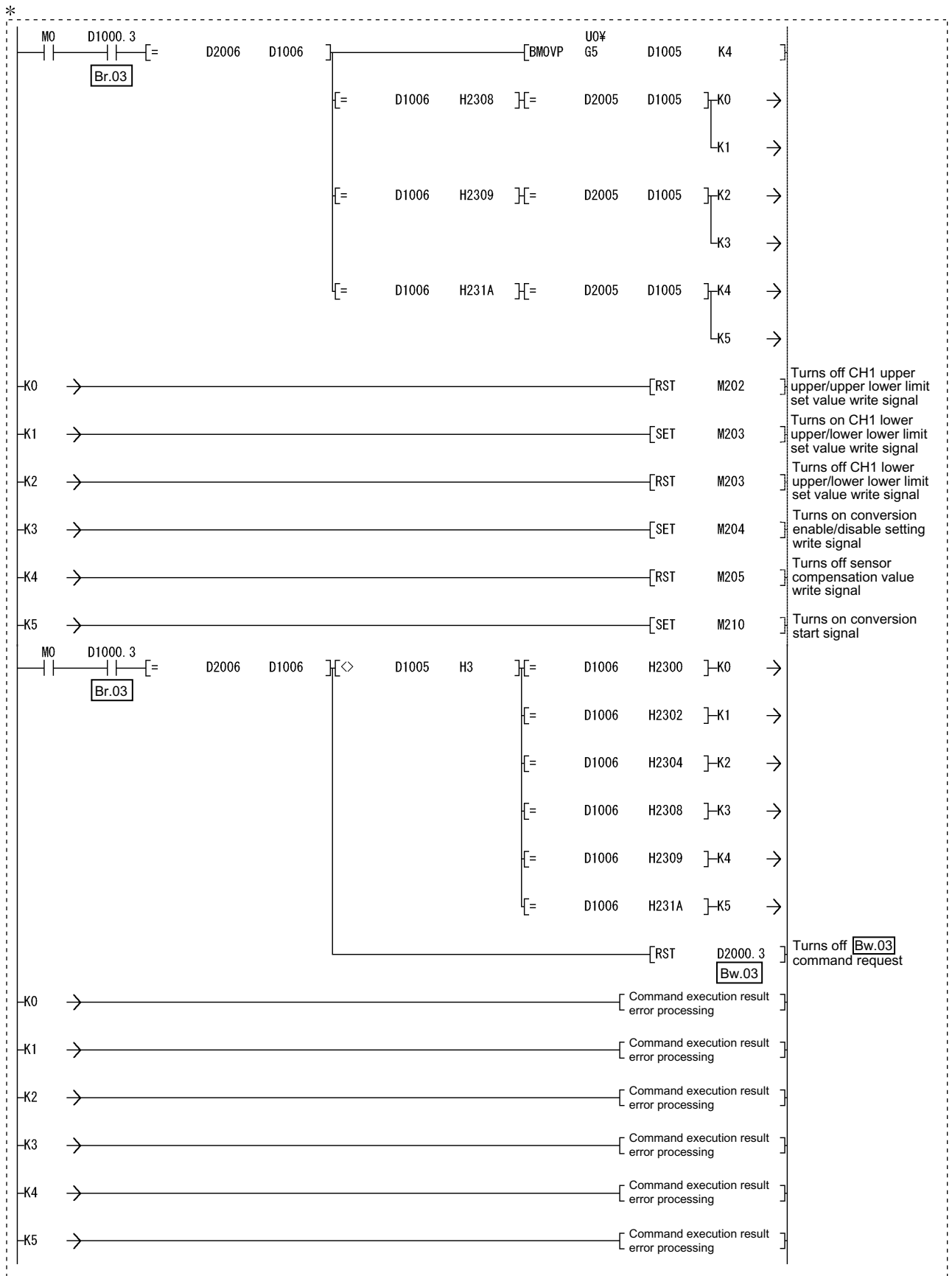

* The program area enclosed by the dotted line is not required when GX Configurator-ST is used to set the command parameters.

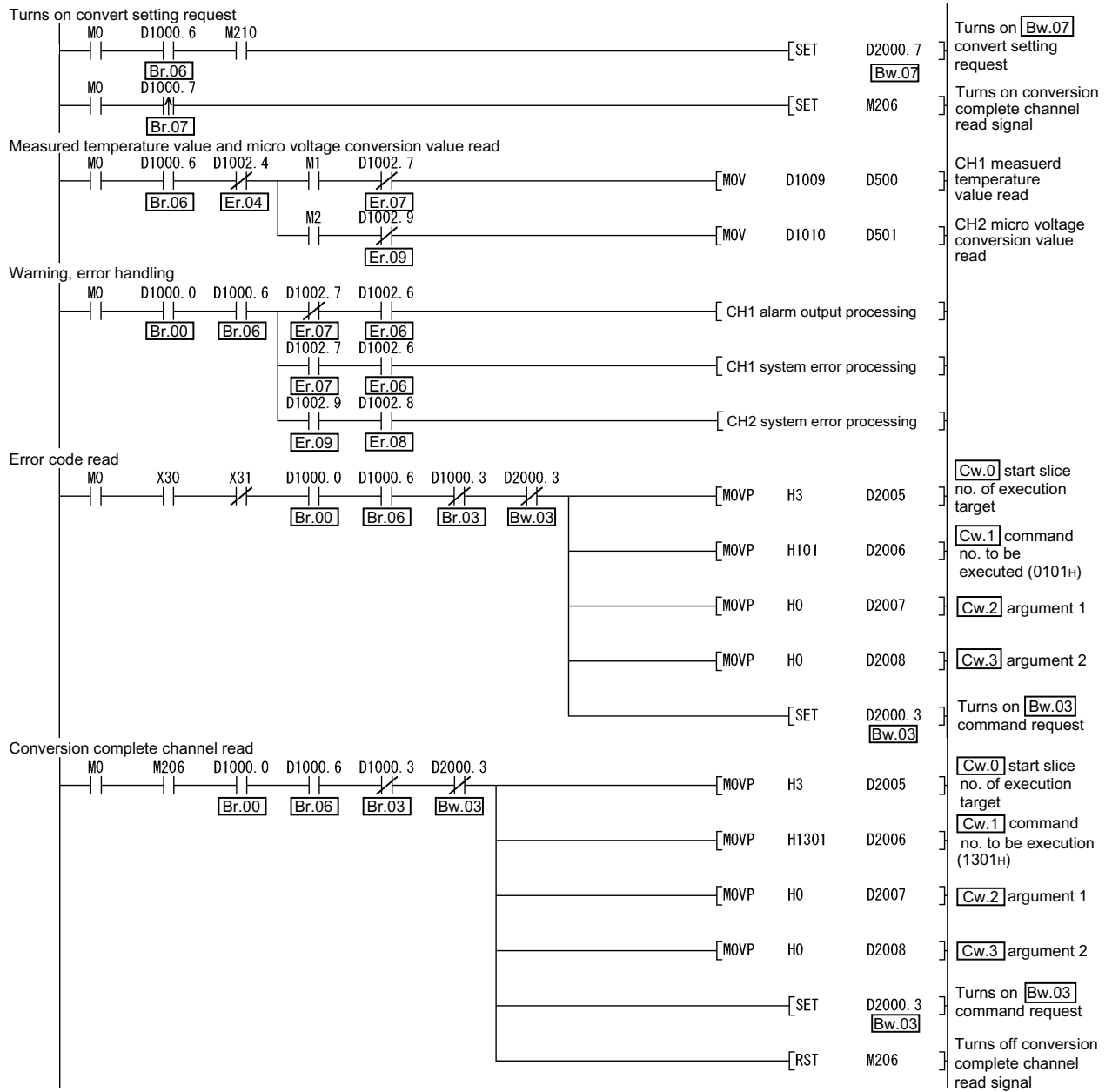

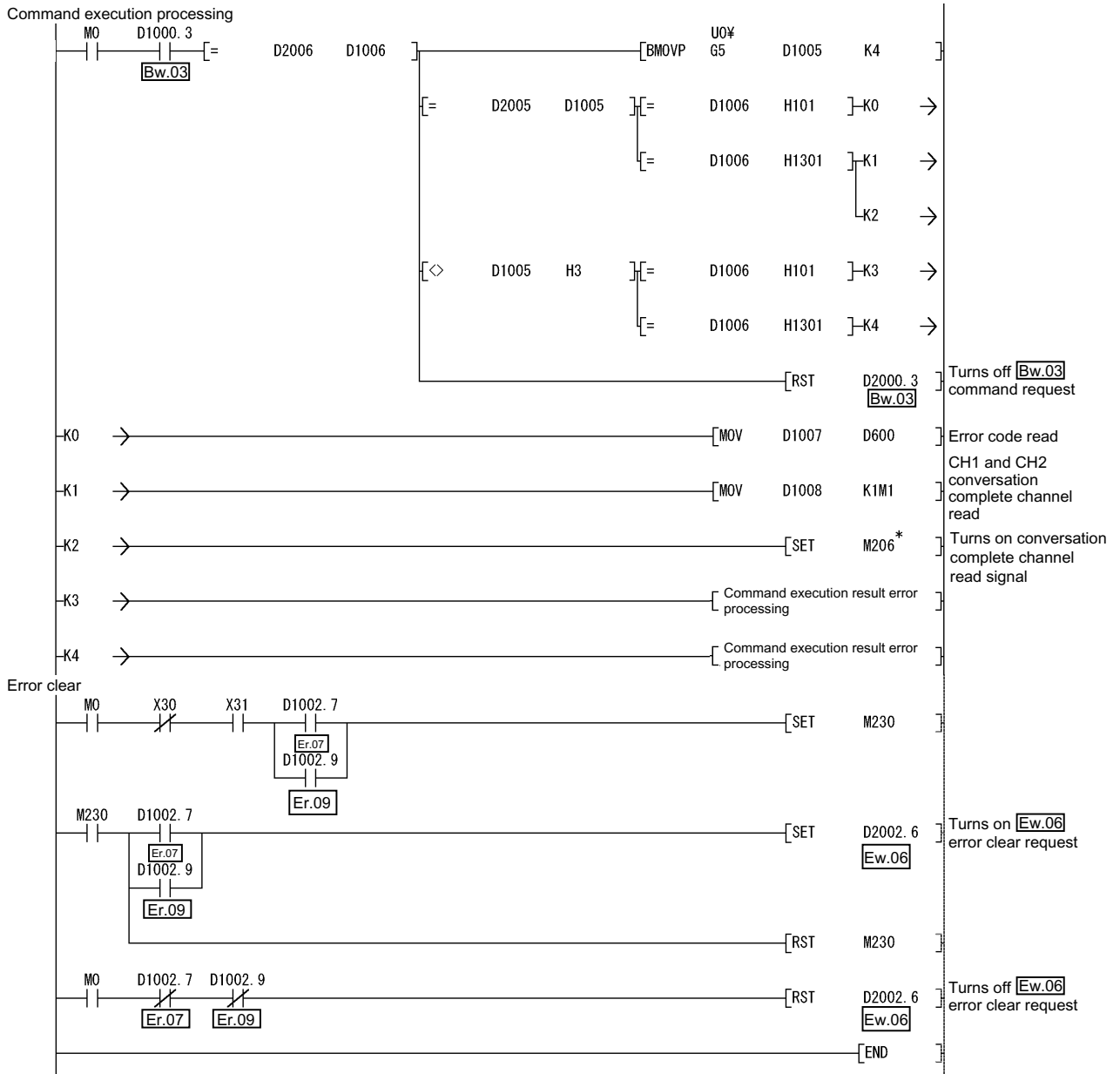

* To use more than one ST1TD2, change the part marked with an asterisk (*) to the conversion complete channel read signal of the 2nd ST1TD2 or after, and add the relevant conversion complete channel read program and the processing program for command execution.

6.3 When Using AJ71PB92D/A1SJ71PB92D as Master Station

This section explains a program example available when the AJ71PB92D/A1SJ71PB92D is used as the master station.

The program example shown here is the case where the A1SJ71PB92D is used as the master station.

(1) System configuration of master station (A1SJ71PB92D)

The system configuration of the master station (A1SJ71PB92D) used in this section is shown below.

(a) System configuration of master station (A1SJ71PB92D)

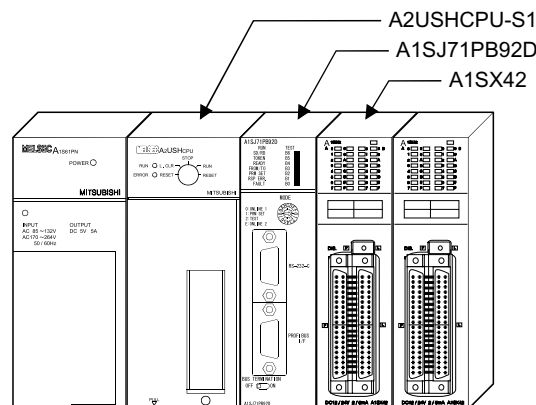

(b) Settings of master station (A1SJ71PB92D)

Item	Setting	
I/O signals	X/Y000 to X/Y01F	
Operation mode	Extended service mode (MODE E)	
I/O data area (buffer memory) for FDL address 1 (MELSEC-ST system)	Input data	0(0H) to 10(0AH)
	Output data	960(3C0H) to 970(3CAH)

REMARK

The MELSEC-ST system changes in I/O data size depending on the maximum input/output point setting and the number of mounted intelligent function modules. Hence, the master station operation mode is set to the extended service mode (MODE E) where the data size is variable.

(2) System configuration of MELSEC-ST system

The MELSEC-ST system has the system configuration as described in Section 6.2 (2).

(3) I/O data assignment

The I/O data assignment result is the same as that described in Section 6.2 (3).

(4) Device assignment in program examples

The program example in this section uses the following device assignment.

(a) Devices used by A1SJ71PB92D

Device	Application	Device	Application
X0	Exchange start end signal	Y0	Exchange start request signal
X0D	Watchdog timer error signal	—	—
X1B	Communication READY signal		
X1D	Module READY signal		

(b) Devices used by user

Device	Application	Device	Application
X20	PROFIBUS-DP exchange start command	M0	Refresh start request
X30	ST1TD2 error code read request	M1	CH1 conversion completed signal
X31	ST1TD2 error clear request	M2	CH2 conversion completed signal
D500	CH1 measured temperature value read destination	M100	Command execution signal
D501	CH2 micro voltage conversion value read destination	M200	Operation condition set value write signal
D600, D601	ST1TD2 error code read destination	M201	Average time/average number of times set value write signal
—	—	M202	CH1 upper upper/upper lower limit set value write signal
		M203	CH1 lower upper/lower lower limit set value write signal
		M204	Conversion enable/disable setting write signal
		M205	Sensor compensation value write signal
		M206	Conversion completed channel read signal
		M210	Conversion start signal
—	—	M210	Conversion start signal
		M230	ST1TD2 error clear request signal

(c) Devices used in I/O data

1) **Br** Bit input area

Br.n	Bit input	Information	Master station side device	Slice No.	Module name
Br.00	Module READY		B0	0	ST1H-PB
Br.01	Forced output test mode		B1		
Br.02	Module being changed online		B2	1	ST1H-PB
Br.03	Command execution		B3		
Br.04	External power supply		B4	2	ST1PSD
Br.05	status		B5		
Br.06	Module ready		B6	3	ST1TD2
Br.07	Convert setting completed flag		B7		
Br.08	Conversion completed flag		B8	4	ST1TD2
Br.09	Alarm output signal		B9		
Br.0A	—		BA	—	—
to					
Br.1F	—		B1F	—	—

2) **Er** Error information area

Er.n Error information	Information	Master station side device	Slice No.	Module name
Er.00	Head module error information	B20	0	ST1H-PB
Er.01		B21		
Er.02		B22	1	
Er.03		B23		
Er.04	Bus refreshing module error information	B24	2	ST1PSD
Er.05		B25		
Er.06	CH1 error information	B26	3	ST1TD2
Er.07		B27		
Er.08	CH2 error information	B28	4	
Er.09		B29		
Er.0A	—	B2A	—	—
to				
Er.1F	—	B3F	—	—

3) **Mr** Module status area

Mr.n Module status	Information	Master station side device	Slice No.	Module name
Mr.0	Head module existence information	B40	0	ST1H-PB
Mr.1		B41	1	
Mr.2	Bus refreshing module existence information	B42	2	ST1PSD
Mr.3	Module status	B43	3	ST1TD2
Mr.4		B44	4	
Mr.5	—	B45	—	—
to				
Mr.15	—	B4F	—	—

4) **Cr** Command result area

Cr Command result area	Information	Master station side device	Slice No.	Module name
Cr.0	Cr.0(15-8) Command Execution Result, Cr.0(7-0) Start Slice No. of Execution Target	W0	—	—
Cr.1	Executed Command No.	W1		
Cr.2	Response Data 1	W2		
Cr.3	Response Data 2	W3		

5) **Wr** Word input area

Wr.n Word input	Information	Master station side device	Slice No.	Module name
Wr.00	CH1 measured temperature value/micro voltage conversion value (Wr.n)	W4	3	ST1TD2
Wr.01	CH2 measured temperature value/micro voltage conversion value (Wr.n+1)	W5		

6) **Bw** Bit output area

Bw.n Bit output	Information	Master station side device	Slice No.	Module name
Bw.00	System area (0 fixed)	B1000	0	ST1H-PB
Bw.01	System area (0 fixed)	B1001		
Bw.02	System area (0 fixed)	B1002		
Bw.03	Command request	B1003	1	
Bw.04	System area (0 fixed)	B1004	2	ST1PSD
Bw.05	System area (0 fixed)	B1005		
Bw.06	System area (0 fixed)	B1006	3	ST1TD2
Bw.07	Convert setting request	B1007		
Bw.08	System area (0 fixed)	B1008	4	
Bw.09	System area (0 fixed)	B1009		
Bw.0A	—	B100A	—	—
to				
Bw.1F	—	B101F	—	—

7) **Ew** Error clear area

Ew.n Error clear	Information	Master station side device	Slice No.	Module name
Ew.00	Error clear request	B1020	0	ST1H-PB
Ew.01	System area (0 fixed)	B1021		
Ew.02	System area (0 fixed)	B1022		
Ew.03	System area (0 fixed)	B1023	1	
Ew.04	Error clear request	B1024	2	ST1PSD
Ew.05	System area (0 fixed)	B1025		
Ew.06	Error clear request	B1026	3	ST1TD2
Ew.07	System area (0 fixed)	B1027		
Ew.08	System area (0 fixed)	B1028	4	
Ew.09	System area (0 fixed)	B1029		
Ew.0A	—	B102A	—	—
to				
Ew.1F	—	B103F	—	—

8) **Sw** System area

Sw System area	Information	Master station side device	Slice No.	Module name
Sw.0	System area (0 fixed)	B1040 to B104F	—	—

9) **Cw** Command execution area

Cw Command execution area	Information	Master station side device	Slice No.	Module name
Cw.0	Start Slice No. of Execution Target	W1000	—	—
Cw.1	Command No. to be Executed	W1001		
Cw.2	Argument 1	W1002		
Cw.3	Argument 2	W1003		

10) **Ww** Word output area

Ww Word output	Information	Master station side device	Slice No.	Module name
Ww.00	System area (0 fixed) (Ww.n)	W1004	3	ST1TD2
Ww.01	System area (0 fixed) (Ww.n+1)	W1005		

(5) Program example

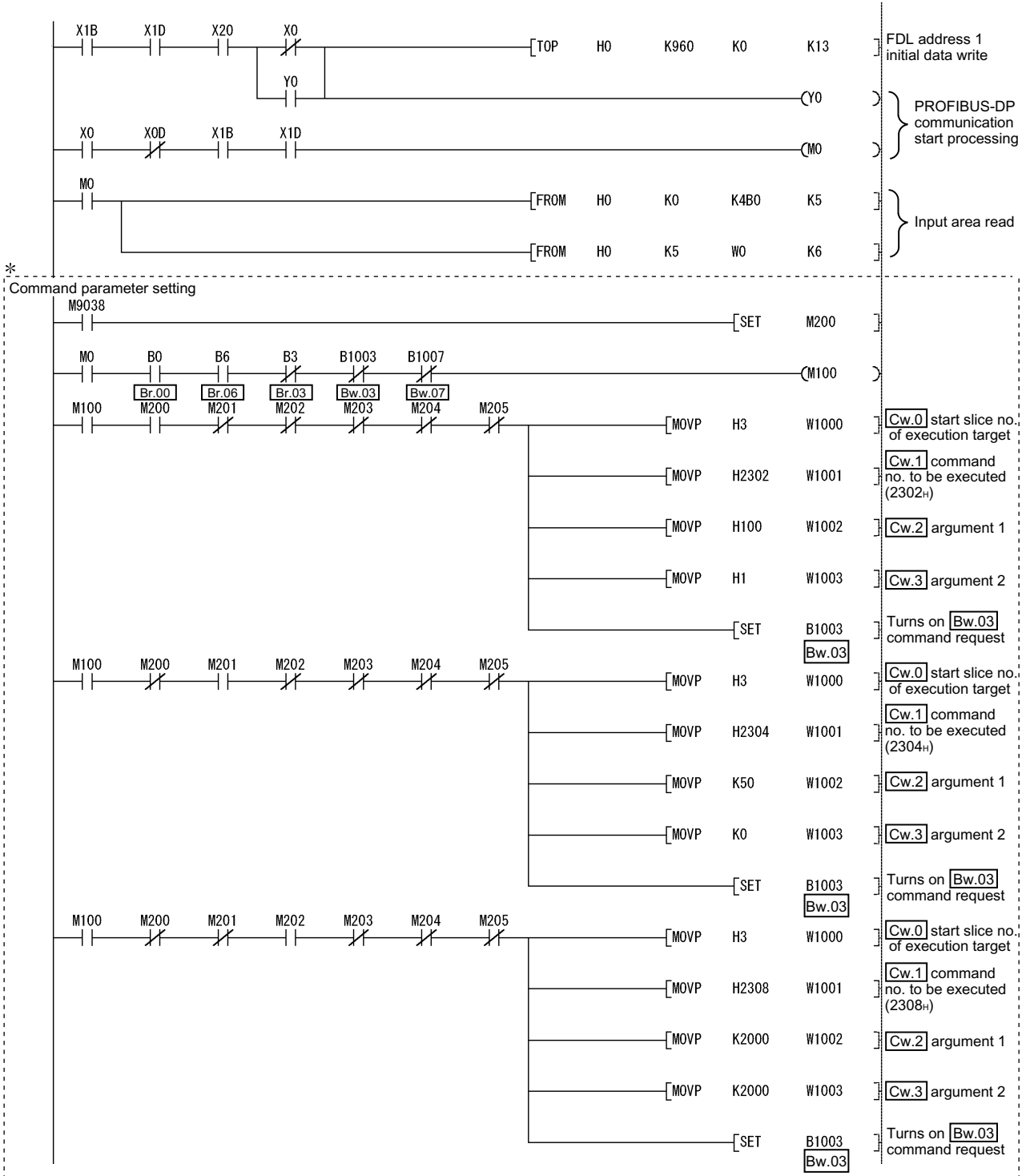

* The program area enclosed by the dotted line is not required when GX Configurator-ST is used to set the command parameters.

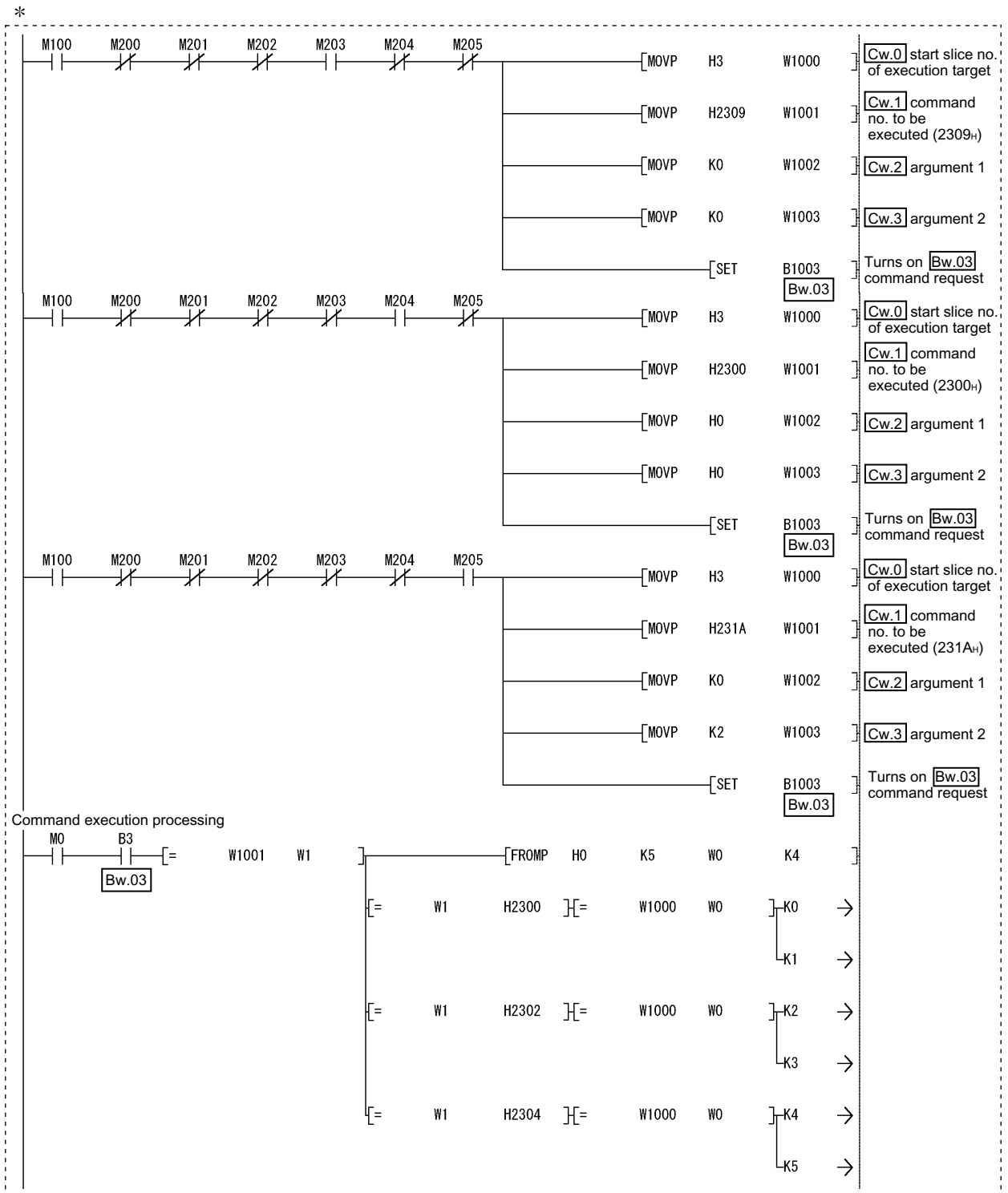

* The program area enclosed by the dotted line is not required when GX Configurator-ST is used to set the command parameters.

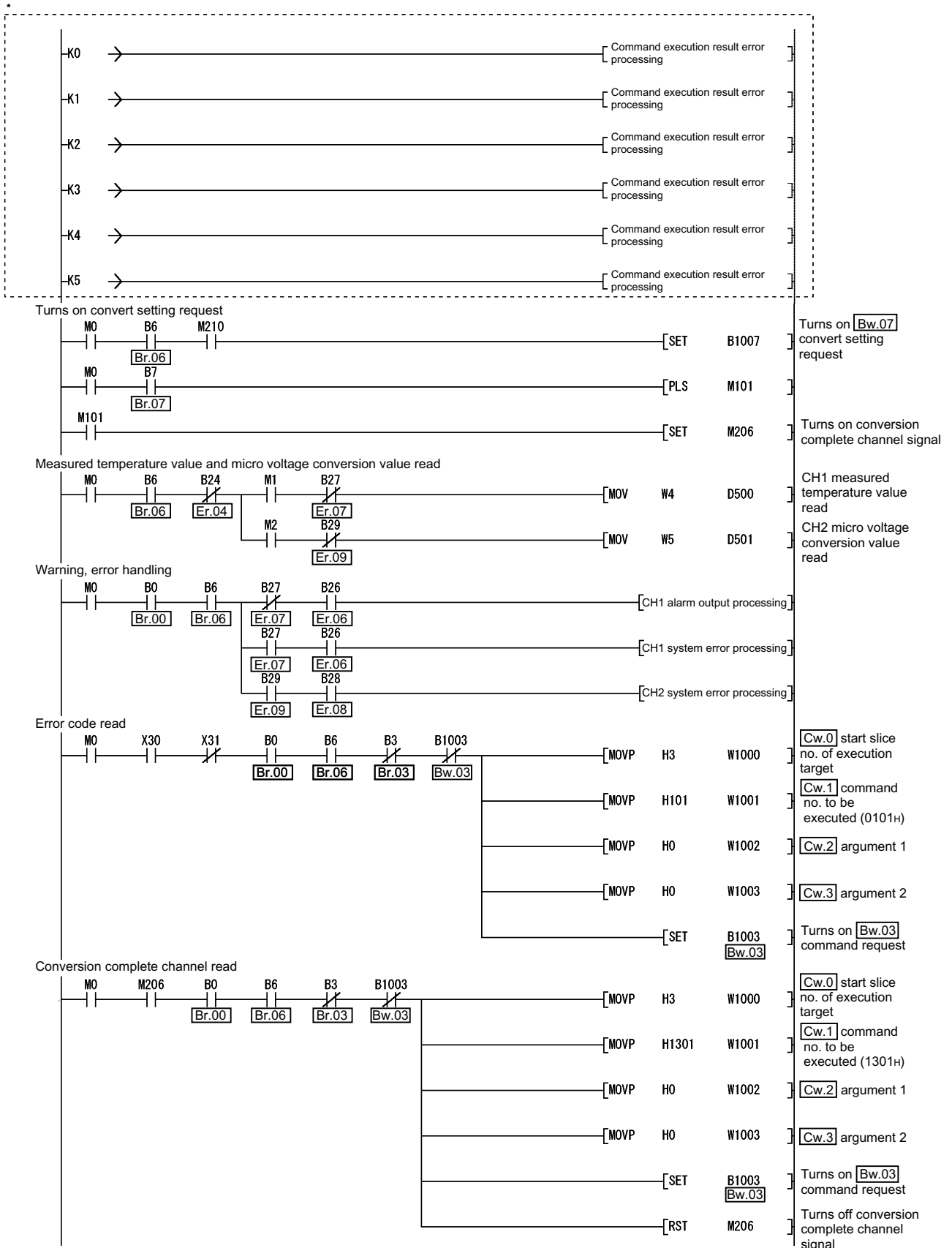

* The program area enclosed by the dotted line is not required when GX Configurator-ST is used to set the command parameters.

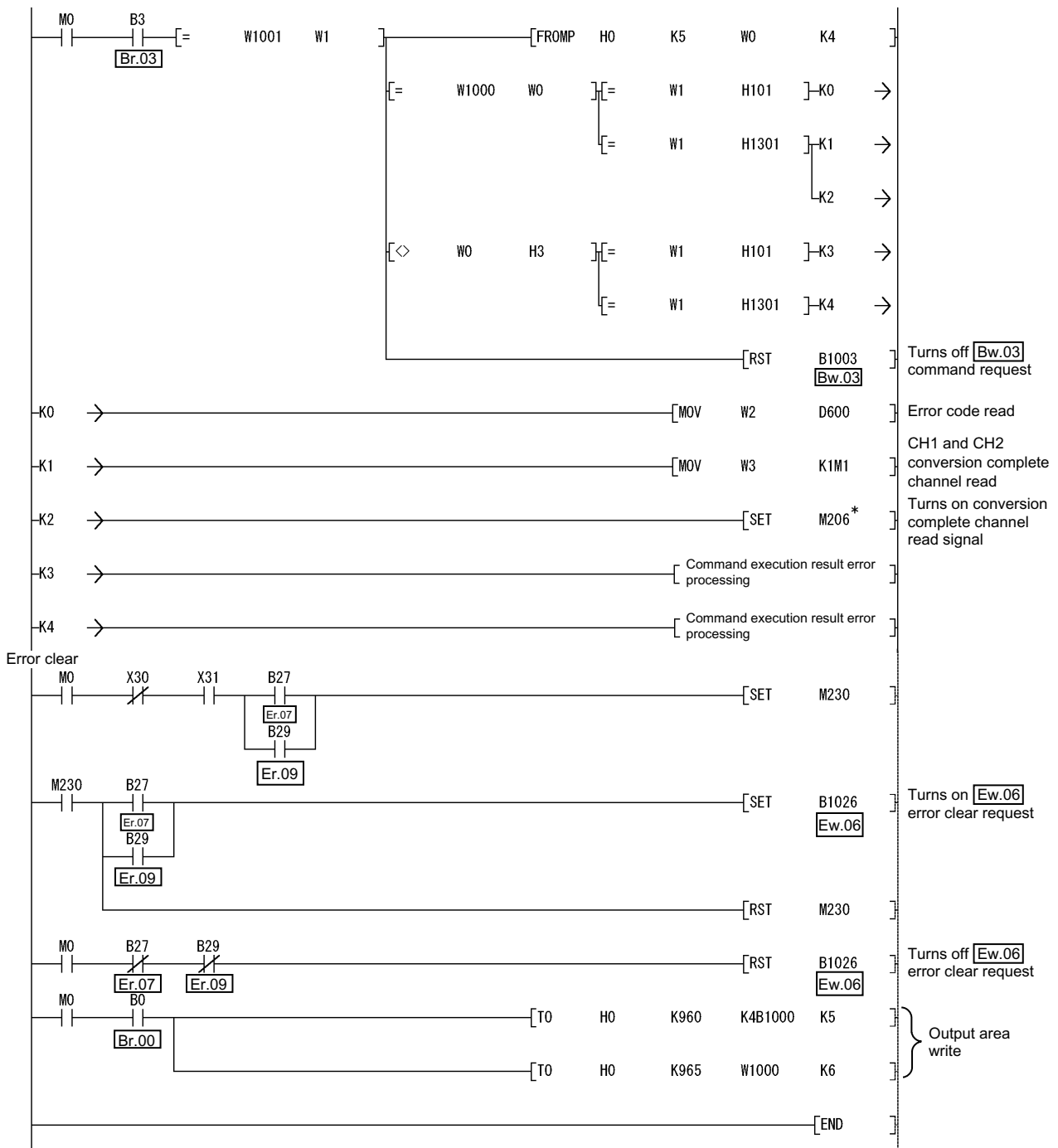

* To use more than one ST1TD2, change the part marked with an asterisk (*) to the conversion complete channel read signal of the 2nd ST1TD2 or after, and add the relevant conversion complete channel read program and the processing program for command execution.

7 ONLINE MODULE CHANGE

When performing online module change, make sure to read through Section 4.4 "Online module change" in the head module user's manual.

This chapter describes the specifications of an online module change.

- (1) Perform an online module change by operating the head module buttons or using GX Configurator-ST.
- (2) The user parameter, command parameter and user range setting's offset/gain setting values are automatically handed down to the new module.
- (3) Using GX Configurator-ST, the offset/gain setting can be made during an online module change.
When higher accuracy is required, perform the offset/gain setting during an online module change using GX Configurator-ST.

7.1 Precautions for Online Module Change

The following are the precautions for online module change.

- (1) To perform the online module change, the system configuration must be appropriate for execution of the online module change.
For details, refer to the MELSEC-ST System User's Manual, "3.4 Precautions for System Configuration".
Executing the online module change in an inappropriate system configuration may result in malfunction or failure.
In such a system configuration, shut off all phases of the external power supply for the MELSEC-ST system to replace a slice module.
- (2) Be sure to perform an online module change in the "online module change procedure" in the user's manual of the used head module and in the procedure given in Section 7.4.1 of this manual.
Failure to do so can cause a malfunction or failure.
- (3) Before starting an online module change, confirm that the external device connected with the slice module to be removed will not malfunction.
- (4) Only the slice modules of the same model name can be replaced online. It is not possible to replace with/add the slice module of different model name.
- (5) Only one slice module can be replaced in a single online module change process.
To replace multiple slice modules, perform an online module change for each module.
- (6) While an online module change is being executed (while the REL. LED of the head module is on), no command can be executed from the master station to the slice module being replaced online.
To do so will cause an error.

- (7) When changing the user parameter of the slice module from the master station during online module change (while the head module's REL. LED is on), change it after the online module change is completed.
If the user parameter setting is changed from the master station during the online module change, the new setting is not validated since the new user parameter values are overwritten by the user parameter saved in the head module when the online module change is finished.
- (8) During an online module change, the ERR. LED of the head module turns on only when an error related to the online module change occurs.
It will not turn on or flicker when any other error occurs.
- (9) While an online module change is being executed (while the REL. LED of the head module is on), the following data of the slice module being replaced online all turn to 0 (OFF).
- Br.n Bit input
 - Er.n Error information
 - Mr.n Module status
 - Wr.n Word input
- (10) After an online module change, the accuracy of the user range setting is decreased about three times or more compared with the one before the online module change.
When the user range setting is used, set the offset and gain values again as necessary.
- (11) Make sure to perform online module change in the normal mode.
- (12) Except the error clear request, the forced output test of GX Configurator-ST cannot be used for the module being changed online.
If it is used, the module will not operate. It will not display an error, either.

7.2 Preparations for Online Module Change

Prepare GX Configurator-ST when changing the ST1TD2 online.

Depending on the module failure status, the user parameter, command parameter and user range setting's offset/gain setting values may not be saved into the head module. Refer to Section 7.4.1 for the procedure used in the parameter setting or offset/gain setting during an online module change.

When GX Configurator-ST is unavailable, make the following preparations.

Failure to do so may not import the offset/gain setting values of user range setting and others to the new module, if these settings cannot be saved into the head module.

(1) Command parameter

When GX Configurator-ST is unavailable, the command parameter must be set by commands after an online module change is finished. Include a command parameter setting program in the master station program.

Refer to Section 6.2.1 and Section 6.3 for the command parameter setting program.

(2) Offset/gain setting values

When the user range setting is used and GX Configurator-ST is unavailable, the offset/gain setting must be made by commands after completion of online module change. Include an offset/gain setting program in the master station program.

Refer to Section 4.5 for the offset/gain setting program.

POINT
When GX Configurator-ST is unavailable, set the command parameter and offset/gain setting values after the module has operated once by default.

REMARK
The preparations for the user parameter are not specially required since the values set by the configuration software of the master station are written from the head module.

7.3 Disconnecting/Connecting the External Device for Online Module Change

Disconnect and connect the ST1TD2 external device according to the following.

(1) Disconnection

Power off the external device.

(2) Connection

Power on the external device.

7.4 Online Module Change Procedure

This section explains how to make the parameter setting or offset/gain setting during an online module change when the user parameter, command parameter and user range setting's offset/gain setting values could not be saved in the head module or when the user range setting is used and high accuracy is required.

For the other online module change procedure, refer to the user's manual of the head module.

7.4.1 When parameter setting or offset/gain setting is performed using GX Configurator-ST during online module change

POINT
<p>If a slice module different from the target one is selected by mistake, restart the operation as instructed below.</p> <ol style="list-style-type: none"><li data-bbox="432 835 1428 902">(1) To restart the operation at step 3) Click the Cancel button on the screen to terminate online module change.<li data-bbox="432 907 1428 1014">(2) When you noticed on the screen in step 4) Do not change the slice module, click the Next button, and perform the operations in steps 7), 12), 13) to complete the online module change once.<li data-bbox="432 1019 1428 1126">(3) To restart the operation at step 7) Mount the removed slice module again, click the Next button, and perform the operations in steps 12), 13) to complete the online module change once.

Preparation for replacing ST1TD2

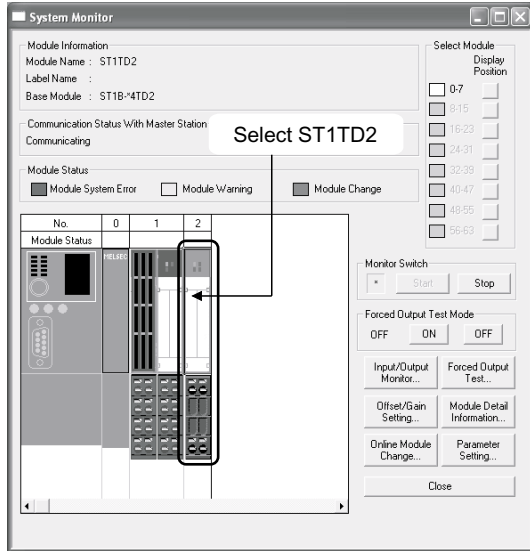

- 1) Select the ST1TD2 to be replaced online on the "System Monitor" screen.

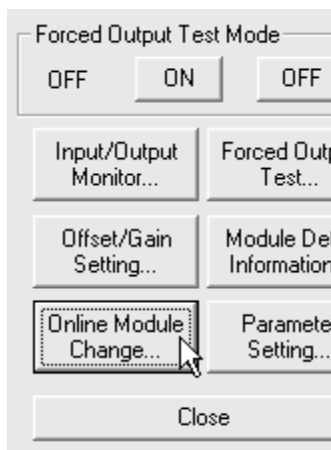

- 2) Click the **Online Module Change** button on the "System Monitor" screen.
Then, confirm that the RUN LED of the selected ST1TD2 is flashing at 0.25s intervals.

REMARK

- Instead of the above, the following operations are also available.
- Select [Diagnostics] → [Online Module Change].
 - Right-click the ST1TD2 selected at step 1), and click [Online Module Change] on the menu.

(Continued to next page.)

(From the previous page.)

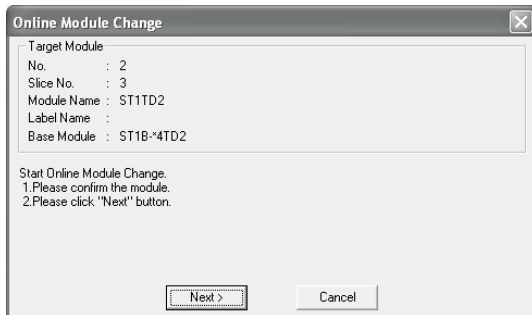

3) Confirm that the ST1TD2 displayed as "Target Module" is the ST1TD2 to be replaced and click the **Next** button.

(a) Clicking the **Next** button validates the settings and the following will be performed.

- Puts the head module into the online module change mode.
- Save the user parameter, command parameter and user range setting's offset/gain setting values of the ST1TD2 to be changed into the head module.

(b) After clicking the **Next** button, confirm the following module statuses.

- The REL. LED of the head module is on.
- The RUN LED of the target ST1TD2 is off.
- The "Module Status" indicator of the target module has turned purple. This applies only when monitoring from the "System Monitor" screen.

(c) If the user parameter, command parameter and user range setting's offset/gain setting values could not be read from the ST1TD2, the REL. LED and ERR. LED of the head module turn on and the corresponding error message is displayed on the screen by the operation in step 7).

Confirm the error definition.

For details of the error code reading operation and error code of the head module, refer to the user's manual of the used head module.

When making parameter setting and offset/gain setting to the new ST1TD2, perform the operations in step 4, and later.

When not executing online module change, click the **Cancel** button.

(a) Clicking the **Cancel** button causes the screen to show that online module change is cancelled.

Clicking the **Exit** button returns to the step 1).



(Continued to next page.)

(From the previous page.)



Disconnection from external device

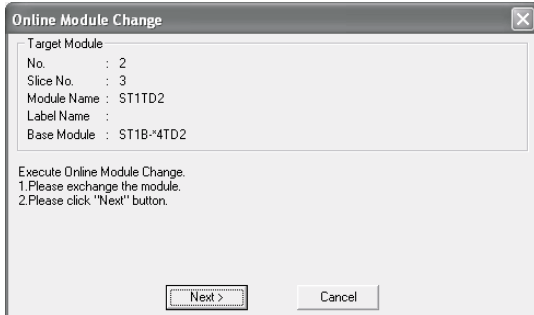

- 4) As the left screen appears, power off the external device connected with the ST1TD2 to be removed.

POINT

If the external device cannot be powered off, shut off all phases of the external power for the MELSEC-ST system and replace the ST1TD2.



Replacing ST1TD2

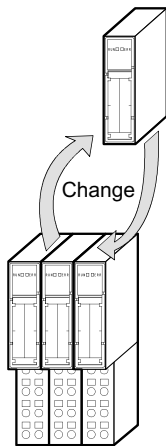

- 5) Remove the ST1TD2 and replace with new one.



Connection to external device after replacement

- 6) Mount a new ST1TD2. And then, power on the external device.



(Continued to next page.)

(From the previous page.)



Operations after external device connection

- 7) After connecting to the external device, click the **Next** button on the screen at step 4).
- (a) Clicking the **Next** button performs the following.
- Checks whether the module name of the newly mounted slice module is the same as that of the removed one.
 - Write the user parameter, command parameter and user range setting's offset/gain setting values, which were saved in the head module in step 3), to the mounted ST1TD2.
- (b) After clicking the **Next** button, confirm the following module statuses.
- The REL. LED of the head module is flashing.
 - The RUN LED of the newly mounted ST1TD2 is flashing (at 0.25s intervals).

Clicking the **Cancel** button, i.e., interrupting online module change returns to step 1) In this case, select the same slice module as selected before, and complete online module change. Note that selecting different one causes an error.

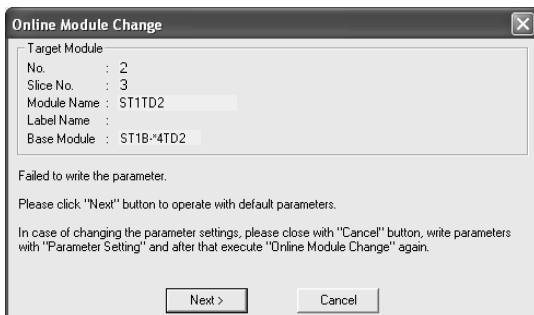

(Continued to next page.)

If the parameter setting or user range setting's offset/gain setting values could not be written to the ST1TD2, the REL. LED and ERR. LED of the head module turn on and the screen shown on the left appears.

Confirm the error definition.

For details of the error code reading operation and error code of the head module, refer to the user's manual of the used head module.

(From the previous page.)



Parameter setting/offset/gain setting

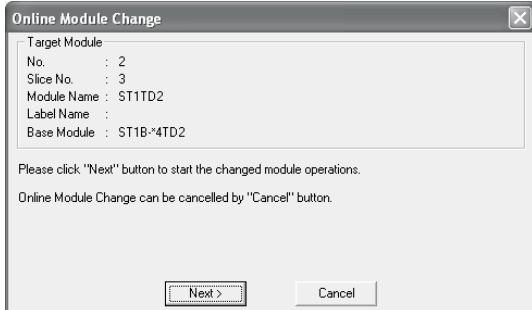

8) Click the **Cancel** button to stop the online module change.

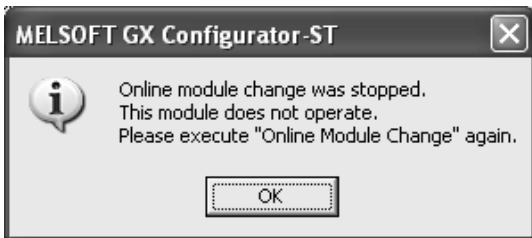

9) Click the **OK** button.



10) Make parameter setting or offset/gain setting.
 Follow the procedure in Section 5.3 for the parameter setting, or the procedure in Section 5.6 for the offset/gain setting. The following describes the POINT of parameter setting and offset/gain setting to be noted during the online module change.

POINT
(1) As the system is already in the diagnostic mode, the mode need not be changed.
(2) When setting the parameters during an online module change, write them to both the RAM and ROM. After the control resumes, the module will operates with the setting written on the RAM.
(3) If the parameter setting or user range setting's offset/gain setting values could not be read from the old ST1TD2, the user parameter have been written when the operation in step 7, was performed. Using GX Configurator-ST, check whether the user parameter have been written.
(4) When offset/gain setting was made during an online module change, the RUN LED of the ST1TD2 flickers at 0.25s intervals even in the offset/gain setting mode.



(Continued to next page.)

(From the previous page.)



Processing after parameter setting or offset/gain setting

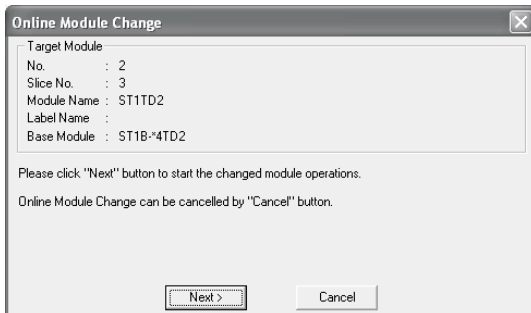

11) After parameter setting or offset/gain setting, execute the operations in steps 1), 2) to resume the online module change.

* Select the same ST1TD2 as before the online module change was stopped.

If the selected ST1TD2 is different, an error will occur.

12) Clicking the **Next** button releases the head module from the online module change mode.

(a) Clicking the **Next** button performs the following.

- Releases the head module from the online module change mode.
- Restarts refreshing the I/O data, etc.

(b) After clicking the **Next** button, confirm the following module statuses.

- The REL. LED of the head module is off.
- The RUN LED of the newly mounted ST1TD2 is on.
- The "Module Status" indicator of the target ST1TD2 has turned white. This applies only when monitoring from the "System Monitor" screen.

(c) If the head module cannot be released from the online module change mode, both REL. LED and ERR. LED of the head module turn on.

Confirm the error definition.

For details of the error code reading operation and error code of the head module, refer to the user's manual of the used head module.

When interrupting online module exchange, click the **Cancel** button.

(a) Clicking the **Cancel** button, i.e., interrupting online module change returns to step 1). In this case, select the same slice module as selected before, and complete online module change.

Note that selecting different one causes an error.



(Continued to next page.)

(From the previous page.)

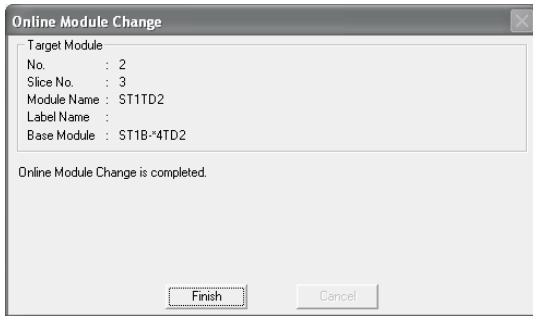

13) The left screen appears showing that online module change has been completed. Click the **Finish** button.



(Completed)

8 COMMAND

This chapter explains the commands.

8.1 Command List

The ST1TD2 supports command execution that uses the \boxed{Cw} Command execution area/ \boxed{Cr} Command result area of the head module.

For the command execution procedure, refer to the user's manual of the used head module.

A list of commands that can be executed by the ST1TD2 is given in Table 8.1.

Table 8.1 Command List (1/2)

Command			Description	Executability			Reference section
Command type	Command No.	Command name		1)	2)	3)	
Common command	0100H	Operating status read request	Reads the operating status of the ST1TD2.	○	○	○	Section 8.2.1
	0101H	Error code read request	Reads the error code of the ST1TD2.	○	○	○	Section 8.2.2
ST1TD2 parameter setting read command	1300H	Conversion enable/disable setting read	Reads the conversion enable/disable setting from the RAM of the ST1TD2.	○	○	○	Section 8.3.1
	1301H	Conversion completion channel read	Reads the currently valid conversion enable/disable setting and conversion completed status.	○	○	○	Section 8.3.2
	1302H	Operation condition set value read	Reads the sampling process/averaging process specification and alarm output setting from the RAM of the ST1TD2.	○	○	○	Section 8.3.3
	1304H	CH \square average time/average number of times set value read	Reads the set number of times or time amount of the averaging process from the RAM of the ST1TD2.	○	○	○	Section 8.3.4
	1308H	CH1 upper upper/upper lower limit set value read	Reads the upper upper limit value/upper lower limit value/lower upper limit value/lower lower limit value of the alarm output from the RAM of the ST1TD2.	○	○	○	Section 8.3.5
	1309H	CH1 lower upper/lower lower limit set value read					Section 8.3.6
	130AH	CH2 upper upper/upper lower limit set value read					Section 8.3.5
	130BH	CH2 lower upper/lower lower limit set value read					Section 8.3.6
	1318H	User parameter set value read	Reads the input type setting, offset/gain value selection and cold junction temperature compensation setting RAM of the ST1TD2.	○	○	○	Section 8.3.7
	131AH	Sensor compensation value read	From the ST1TD2's RAM, reads out a compensation value when an error is identified between "the actual temperature/voltage" and "the measured temperature/voltage".	○	○	○	Section 8.3.8

○: Can be executed ×: Cannot be executed

1) When $\boxed{Bw.n+1}$ convert setting request is OFF (0) in the normal mode

2) When $\boxed{Bw.n+1}$ convert setting request is ON (1) in the normal mode

3) When the module is in the offset/gain setting mode

Table 8.1 Command List (2/2)

Command			Description	Executability*			Reference section
Command type	Command No.	Command name		1)	2)	3)	
ST1TD2 parameter setting write command	2300H	Conversion enable/disable setting write	Writes the conversion enable/disable setting to the RAM of the ST1TD2.	○	×	×	Section 8.4.1
	2302H	Operation condition set value write	Writes the sampling process/averaging processing specification and alarm output setting to the RAM of the ST1TD2.	○	×	×	Section 8.4.2
	2304H	CH□ average time/average number of times set value write.	Writes the set number of times or time amount of the averaging processing to the RAM of the ST1TD2.	○	×	×	Section 8.4.3
	2308H	CH1 upper upper/upper lower limit set value write	Writes the upper upper limit value/upper lower limit value or lower upper limit value/lower lower limit value of the alarm output to the RAM of the ST1TD2.	○	×	×	Section 8.4.4
	2309H	CH1 lower upper/lower lower limit set value write					Section 8.4.5
	230AH	CH2 upper upper/upper lower limit set value write					Section 8.4.4
	230BH	CH2 lower upper/lower lower limit set value write					Section 8.4.5
	231AH	Sensor compensation value write	Writes a compensation value to the ST1TD2's RAM when an error is identified between "the actual temperature/voltage" and "the measured temperature/voltage".	○	×	×	Section 8.4.6
ST1TD2 control command	3300H	Parameter setting ROM read	Reads the parameters from the ROM of the ST1TD2 to the RAM.	○	×	×	Section 8.5.1
	3301H	Parameter setting ROM write	Writes the parameters from the RAM of the ST1TD2 to the ROM.	○	×	×	Section 8.5.2
	3302H	Operation mode setting	Changes the mode of the ST1TD2.	○	×	○	Section 8.5.3
	3303H	Offset channel specification	Specifies the offset channel of offset/gain setting and adjusts the offset value.	×	×	○	Section 8.5.4
	3304H	Gain channel specification	Specifies the gain channel of offset/gain setting and adjusts the gain value.	×	×	○	Section 8.5.5
	3305H	User range write	Writes the adjusted offset/gain settings to the ROM of the ST1TD2	×	×	○	Section 8.5.6

○: Can be executed ×: Cannot be executed

1) When $\boxed{Bw.n+1}$ convert setting request is OFF (0) in the normal mode2) When $\boxed{Bw.n+1}$ convert setting request is ON (1) in the normal mode

3) When the module is in the offset/gain setting mode

* If a command is executed when it cannot be executed, it fails and "06H" or "13H" is stored into the $\boxed{Cr.0(15-8)}$ Command execution result.

8.2 Common Command

8.2.1 Operating status read request (Command No.: 0100H)

Reads the operating status of the ST1TD2.

(1) Values set to **Cw** Command execution area

Cw Command execution area	Setting value
Cw.0	Set the start slice no. of the ST1TD2 where the command will be executed. (Hexadecimal)
Cw.1	0100H
Cw.2	Fixed to 0000H (Any value other than 0000H is ignored.)
Cw.3	

(2) Execution result in **Cr** Command result area

The execution result of the command changes depending on the result (normal completion or abnormal completion) in **Cr.0(15-8)** Command execution result.

(a) Normal completion (When **Cr.0(15-8)** Command execution result is 00H)

Cr Command result area	Result details												
Cr.0	<p>The command execution result is stored into the higher byte, and the start slice No. of execution target into the lower byte in hexadecimal as shown below.</p> <table border="1" style="margin-left: 20px;"> <tr> <td style="text-align: center;">b15</td> <td style="text-align: center;">to</td> <td style="text-align: center;">b8</td> <td style="text-align: center;">b7</td> <td style="text-align: center;">to</td> <td style="text-align: center;">b0</td> </tr> <tr> <td colspan="3" style="text-align: center;">Cr.0(15-8) Command Execution Result</td> <td colspan="3" style="text-align: center;">Cr.0(7-0) Start Slice No. of Execution Target</td> </tr> </table> <p style="margin-left: 40px;">→ 00H: Normal completion</p>	b15	to	b8	b7	to	b0	Cr.0(15-8) Command Execution Result			Cr.0(7-0) Start Slice No. of Execution Target		
b15	to	b8	b7	to	b0								
Cr.0(15-8) Command Execution Result			Cr.0(7-0) Start Slice No. of Execution Target										
Cr.1	The executed command no. is stored. (Hexadecimal)												
Cr.2	<p>The operating status of the ST1TD2 is stored.</p> <table border="1" style="margin-left: 20px;"> <tr> <td style="text-align: center;">b15</td> <td style="text-align: center;">to</td> <td style="text-align: center;">b1</td> <td style="text-align: center;">b0</td> </tr> <tr> <td colspan="3" style="text-align: center;">0</td> <td style="text-align: center;">1)</td> </tr> </table> <p>1) 0: Normal 1: System error</p>	b15	to	b1	b0	0			1)				
b15	to	b1	b0										
0			1)										
Cr.3	<p>The current operation mode of the ST1TD2 is stored.</p> <table border="1" style="margin-left: 20px;"> <tr> <td style="text-align: center;">b15</td> <td style="text-align: center;">to</td> <td style="text-align: center;">b2</td> <td style="text-align: center;">b1</td> <td style="text-align: center;">b0</td> </tr> <tr> <td colspan="4" style="text-align: center;">0</td> <td style="text-align: center;">1)</td> </tr> </table> <p>1) 01: Normal mode 10: Offset/gain setting mode</p>	b15	to	b2	b1	b0	0				1)		
b15	to	b2	b1	b0									
0				1)									

8.2.2 Error code read request (Command No.: 0101H)

Reads the error code of the ST1TD2.

(1) Values set to **Cw** Command execution area

Cw Command execution area	Setting value
Cw.0	Set the start slice no. of the ST1TD2 where the command will be executed. (Hexadecimal)
Cw.1	0101H
Cw.2	Fixed to 0000H (Any value other than 0000H is ignored.)
Cw.3	

(2) Execution result in **Cr** Command result area

The execution result of the command changes depending on the result (normal completion or abnormal completion) in **Cr.0(15-8)** Command execution result.

(a) Normal completion (When **Cr.0(15-8)** Command execution result is 00H)

Cr Command result area	Result details												
Cr.0	<p>The command execution result is stored into the higher byte, and the start slice No. of execution target into the lower byte in hexadecimal as shown below.</p> <table border="1" style="margin-left: 20px;"> <tr> <td style="text-align: center;">b15</td> <td style="text-align: center;">to</td> <td style="text-align: center;">b8</td> <td style="text-align: center;">b7</td> <td style="text-align: center;">to</td> <td style="text-align: center;">b0</td> </tr> <tr> <td colspan="3" style="text-align: center;">Cr.0(15-8) Command Execution Result</td> <td colspan="3" style="text-align: center;">Cr.0(7-0) Start Slice No. of Execution Target</td> </tr> </table> <p style="margin-left: 40px;">→ 00H: Normal completion</p>	b15	to	b8	b7	to	b0	Cr.0(15-8) Command Execution Result			Cr.0(7-0) Start Slice No. of Execution Target		
b15	to	b8	b7	to	b0								
Cr.0(15-8) Command Execution Result			Cr.0(7-0) Start Slice No. of Execution Target										
Cr.1	The executed command no. is stored. (Hexadecimal)												
Cr.2	The error code currently occurring in the ST1TD2 is stored. (Hexadecimal) Refer to Section 9.1 for details of the error code.												
Cr.3	<p>The alarm information is stored for each channel.</p> <table border="1" style="margin-left: 20px;"> <tr> <td style="text-align: center;">b15</td> <td style="text-align: center;">to</td> <td style="text-align: center;">b4</td> <td style="text-align: center;">b3 to b0</td> </tr> <tr> <td colspan="3" style="text-align: center;">0</td> <td style="text-align: center;">1)</td> </tr> </table> <p>1) CH□ alarm status (b0: CH1 upper limit value, b1: CH1 lower limit value, b2: CH2 upper limit value, b3: CH2 lower limit value) 0: Normal 1: Alarm occurrence</p>	b15	to	b4	b3 to b0	0			1)				
b15	to	b4	b3 to b0										
0			1)										

8.3 ST1TD2 Parameter Setting Read Command

8.3.1 Conversion enable/disable setting read (Command No.: 1300H)

Reads the conversion enable/disable setting from the RAM of the ST1TD2.

(1) Values set to **Cw** Command execution area

Cw Command execution area	Setting value
Cw.0	Set the start slice no. of the ST1TD2 where the command will be executed. (Hexadecimal)
Cw.1	1300H
Cw.2	Fixed to 0000H (Any value other than 0000H is ignored.)
Cw.3	

(2) Execution result in **Cr** Command result area

The execution result of the command changes depending on the result (normal completion or abnormal completion) in **Cr.0(15-8)** Command execution result.

(a) Normal completion (When **Cr.0(15-8)** Command execution result is 00H)

Cr Command result area	Result details		
Cr.0	<p>The command execution result is stored into the higher byte, and the start slice No. of execution target into the lower byte in hexadecimal as shown below.</p> <p>b15 to b8 b7 to b0</p> <table border="1" style="margin-left: 40px;"> <tr> <td style="width: 80px;">Cr.0(15-8) Command Execution Result</td> <td style="width: 80px;">Cr.0(7-0) Start Slice No. of Execution Target</td> </tr> </table> <p style="margin-left: 100px;">} → 00H: Normal completion</p>	Cr.0(15-8) Command Execution Result	Cr.0(7-0) Start Slice No. of Execution Target
Cr.0(15-8) Command Execution Result	Cr.0(7-0) Start Slice No. of Execution Target		
Cr.1	The executed command no. is stored. (Hexadecimal)		
Cr.2	<p>The conversion enable/disable setting written to the RAM is stored for each channel.</p> <p>b15 to b2 b1 b0</p> <table border="1" style="margin-left: 40px;"> <tr> <td style="width: 120px; text-align: center;">0</td> <td style="width: 20px; text-align: center;">1)</td> </tr> </table> <p>1) CH□ Conversion enable/disable setting (b0: CH1, b1: CH2) 0: Conversion enable 1: Conversion disable</p>	0	1)
0	1)		
Cr.3	0000H		

8.3.2 Conversion completion channel read (Command No.: 1301H)

Reads the currently valid conversion enable/disable setting and conversion completed status.

(1) Values set to **Cw** Command execution area

Cw Command execution area	Setting value
Cw.0	Set the start slice no. of the ST1TD2 where the command will be executed. (Hexadecimal)
Cw.1	1301H
Cw.2	Fixed to 0000H (Any value other than 0000H is ignored.)
Cw.3	

(2) Execution result in **Cr** Command result area

The execution result of the command changes depending on the result (normal completion or abnormal completion) in **Cr.0(15-8)** Command execution result.

(a) Normal completion (When **Cr.0(15-8)** Command execution result is 00H)

Cr Command result area	Result details												
Cr.0	<p>The command execution result is stored into the higher byte, and the start slice No. of execution target into the lower byte in hexadecimal as shown below.</p> <table border="1" style="margin-left: 20px;"> <tr> <td style="text-align: center;">b15</td> <td style="text-align: center;">to</td> <td style="text-align: center;">b8</td> <td style="text-align: center;">b7</td> <td style="text-align: center;">to</td> <td style="text-align: center;">b0</td> </tr> <tr> <td colspan="3" style="text-align: center;">Cr.0(15-8) Command Execution Result</td> <td colspan="3" style="text-align: center;">Cr.0(7-0) Start Slice No. of Execution Target</td> </tr> </table> <p style="margin-left: 40px;">→ 00H: Normal completion</p>	b15	to	b8	b7	to	b0	Cr.0(15-8) Command Execution Result			Cr.0(7-0) Start Slice No. of Execution Target		
b15	to	b8	b7	to	b0								
Cr.0(15-8) Command Execution Result			Cr.0(7-0) Start Slice No. of Execution Target										
Cr.1	The executed command no. is stored. (Hexadecimal)												
Cr.2	<p>The currently valid conversion enable/disable setting is stored for each channel.</p> <table border="1" style="margin-left: 20px;"> <tr> <td style="text-align: center;">b15</td> <td style="text-align: center;">to</td> <td style="text-align: center;">b2</td> <td style="text-align: center;">b1</td> <td style="text-align: center;">b0</td> </tr> <tr> <td colspan="4" style="text-align: center;">0</td> <td style="text-align: center;">1)</td> </tr> </table> <p>1) CH□ conversion enable/disable setting (b0: CH1, b1: CH2) 0: Conversion enable 1: Conversion disable</p>	b15	to	b2	b1	b0	0				1)		
b15	to	b2	b1	b0									
0				1)									
Cr.3	<p>The conversion completed status is stored for each channel.</p> <table border="1" style="margin-left: 20px;"> <tr> <td style="text-align: center;">b15</td> <td style="text-align: center;">to</td> <td style="text-align: center;">b2</td> <td style="text-align: center;">b1</td> <td style="text-align: center;">b0</td> </tr> <tr> <td colspan="4" style="text-align: center;">0</td> <td style="text-align: center;">1)</td> </tr> </table> <p>1) CH□ conversion completed setting (b0: CH1, b1: CH2) 0: Conversion being executed or not used 1: Conversion completed</p>	b15	to	b2	b1	b0	0				1)		
b15	to	b2	b1	b0									
0				1)									

(b) Abnormal completion (When **Cr.0(15-8)** Command execution result is other than 00H)

Cr Command result area	Result details		
Cr.0	<p>The command execution result is stored into the higher byte, and the start slice No. of execution target into the lower byte in hexadecimal as shown below.</p> <p>b15 to b8 b7 to b0</p> <table border="1" style="margin-left: 40px;"> <tr> <td style="width: 80px;">Cr.0(15-8) Command Execution Result</td> <td style="width: 80px;">Cr.0(7-0) Start Slice No. of Execution Target *1</td> </tr> </table> <p style="margin-left: 100px;"> </p> <p>* 1: When 0FH is stored into the Cr.0(15-8) Command Execution Result, 00H (start slice No. of head module) is stored into the Cr.0(7-0) Start Slice No. of Execution Target.</p>	Cr.0(15-8) Command Execution Result	Cr.0(7-0) Start Slice No. of Execution Target *1
Cr.0(15-8) Command Execution Result	Cr.0(7-0) Start Slice No. of Execution Target *1		
Cr.1	The executed command no. is stored. (Hexadecimal)		
Cr.2	Cw.2 Argument 1 at command execution is stored.		
Cr.3	Cw.3 Argument 2 at command execution is stored.		

8.3.3 Operation condition set value read (Command No.: 1302H)

Reads the averaging process specification and alarm output setting from the RAM of the ST1TD2.

(1) Values set to **Cw** Command execution area

Cw Command execution area	Setting value
Cw.0	Set the start slice no. of the ST1TD2 where the command will be executed. (Hexadecimal)
Cw.1	1302H
Cw.2	Fixed to 0000H (Any value other than 0000H is ignored.)
Cw.3	

(2) Execution result in **Cr** Command result area

The execution result of the command changes depending on the result (normal completion or abnormal completion) in **Cr.0(15-8)** Command execution result.

(a) Normal completion (When **Cr.0(15-8)** Command execution result is 00H)

Cr Command result area	Result details				
Cr.0	<p>The command execution result is stored into the higher byte, and the start slice No. of execution target into the lower byte in hexadecimal as shown below.</p> <p>b15 to b8 b7 to b0</p> <table border="1" style="margin-left: 40px;"> <tr> <td style="width: 80px;">Cr.0(15-8) Command Execution Result</td> <td style="width: 80px;">Cr.0(7-0) Start Slice No. of Execution Target</td> </tr> </table> <p style="margin-left: 100px;">→ 00H: Normal completion</p>	Cr.0(15-8) Command Execution Result	Cr.0(7-0) Start Slice No. of Execution Target		
Cr.0(15-8) Command Execution Result	Cr.0(7-0) Start Slice No. of Execution Target				
Cr.1	The executed command no. is stored. (Hexadecimal)				
Cr.2	<p>The averaging process specification is stored for each channel.</p> <p>b15 to b10 b9 b8 b7 to b2 b1 b0</p> <table border="1" style="margin-left: 40px;"> <tr> <td style="width: 40px;">0</td> <td style="width: 40px;">2)</td> <td style="width: 40px;">0</td> <td style="width: 40px;">1)</td> </tr> </table> <p>1) Time averaging/number of times averaging specification (b0: CH1, b1: CH2) 0: Number of times averaging 1: Time averaging</p> <p>2) Averaging-processed channel specification (b8: CH1, b9: CH2) 0: Sampling process 1: Averaging process</p>	0	2)	0	1)
0	2)	0	1)		
Cr.3	<p>The alarm output setting is stored for each channel.</p> <p>b15 to b2 b1 b0</p> <table border="1" style="margin-left: 40px;"> <tr> <td style="width: 120px;">0</td> <td style="width: 40px;">1)</td> </tr> </table> <p>1) Alarm output setting (b0: CH1, b1: CH2) 0: Alarm output processing not performed 1: Alarm output processing performed</p>	0	1)		
0	1)				

(b) Abnormal completion (When **Cr.0(15-8)** Command execution result is other than 00H)

Cr Command result area	Result details		
Cr.0	<p>The command execution result is stored into the higher byte, and the start slice No. of execution target into the lower byte in hexadecimal as shown below.</p> <p>b15 to b8 b7 to b0</p> <table border="1" style="margin-left: 40px;"> <tr> <td style="width: 80px;">Cr.0(15-8) Command Execution Result</td> <td>Cr.0(7-0) Start Slice No. of Execution Target *1</td> </tr> </table> <p style="margin-left: 100px;"> </p> <p>* 1: When 0FH is stored into the Cr.0(15-8) Command Execution Result, 00H (start slice No. of head module) is stored into the Cr.0(7-0) Start Slice No. of Execution Target.</p>	Cr.0(15-8) Command Execution Result	Cr.0(7-0) Start Slice No. of Execution Target *1
Cr.0(15-8) Command Execution Result	Cr.0(7-0) Start Slice No. of Execution Target *1		
Cr.1	The executed command no. is stored. (Hexadecimal)		
Cr.2	Cw.2 Argument 1 at command execution is stored.		
Cr.3	Cw.3 Argument 2 at command execution is stored.		

8.3.4 CH□ average time/average number of times set value read (Command No.: 1304H)

Reads the set number of times or time amount of the averaging process from the RAM of the ST1TD2.

(1) Values set to **Cw** Command execution area

Cw Command execution area	Setting value
Cw.0	Set the start slice no. of the ST1TD2 where the command will be executed. (Hexadecimal)
Cw.1	1304H
Cw.2	Fixed to 0000H (Any value other than 0000H is ignored.)
Cw.3	

(2) Execution result in **Cr** Command result area

The execution result of the command changes depending on the result (normal completion or abnormal completion) in **Cr.0(15-8)** Command execution result.

(a) Normal completion (When **Cr.0(15-8)** Command execution result is 00H)

Cr Command result area	Result details		
Cr.0	<p>The command execution result is stored into the higher byte, and the start slice No. of execution target into the lower byte in hexadecimal as shown below.</p> <p>b15 to b8 b7 to b0</p> <table border="1" style="margin-left: auto; margin-right: auto;"> <tr> <td style="text-align: center;">Cr.0(15-8) Command Execution Result</td> <td style="text-align: center;">Cr.0(7-0) Start Slice No. of Execution Target</td> </tr> </table> <p style="text-align: center;">→ 00H: Normal completion</p>	Cr.0(15-8) Command Execution Result	Cr.0(7-0) Start Slice No. of Execution Target
Cr.0(15-8) Command Execution Result	Cr.0(7-0) Start Slice No. of Execution Target		
Cr.1	The executed command no. is stored. (Hexadecimal)		
Cr.2	<p>The set number of times or time of the averaging process for channel 1 is stored. The value in the following range is stored.</p> <p>The averaging processing is by the number of times : 4 to 500 (times).</p> <p>The averaging processing by the times : 480 to 5000 (ms).</p>		
Cr.3	<p>The set number of times or time of the averaging process for channel 2 is stored. The range of the stored value is the same as in Cr.2 Response data 1.</p>		

(b) Abnormal completion (When **Cr.0(15-8)** Command execution result is other than 00H)

Cr Command result area	Result details		
Cr.0	<p>The command execution result is stored into the higher byte, and the start slice No. of execution target into the lower byte in hexadecimal as shown below.</p> <p>b15 to b8 b7 to b0</p> <table border="1" style="margin-left: auto; margin-right: auto;"> <tr> <td style="text-align: center;">Cr.0(15-8) Command Execution Result</td> <td style="text-align: center;">Cr.0(7-0) Start Slice No. of Execution Target *1</td> </tr> </table> <p style="text-align: center;"> Other than 00H: Abnormal completion (see Section 8.6) </p> <p>* 1: When 0FH is stored into the Cr.0(15-8) Command Execution Result, 00H (start slice No. of head module) is stored into the Cr.0(7-0) Start Slice No. of Execution Target.</p>	Cr.0(15-8) Command Execution Result	Cr.0(7-0) Start Slice No. of Execution Target *1
Cr.0(15-8) Command Execution Result	Cr.0(7-0) Start Slice No. of Execution Target *1		
Cr.1	The executed command no. is stored. (Hexadecimal)		
Cr.2	Cw.2 Argument 1 at command execution is stored.		
Cr.3	Cw.3 Argument 2 at command execution is stored.		

8.3.5 CH□ upper upper/upper lower limit set value read (Command No.: 1308H, 130AH)

Reads the upper upper limit value/upper lower limit value of the alarm output from the RAM of the ST1TD2.

(1) Values set to **Cw** Command execution area

Cw Command execution area	Setting value
Cw.0	Set the start slice no. of the ST1TD2 where the command will be executed. (Hexadecimal)
Cw.1	CH1 upper upper/upper lower limit set value read: 1308H CH2 upper upper/upper lower limit set value read: 130AH
Cw.2	Fixed to 0000H (Any value other than 0000H is ignored.)
Cw.3	

(2) Execution result in **Cr** Command result area

The execution result of the command changes depending on the result (normal completion or abnormal completion) in **Cr.0(15-8)** Command execution result.

(a) Normal completion (When **Cr.0(15-8)** Command execution result is 00H)

Cr Command result area	Result details		
Cr.0	<p>The command execution result is stored into the higher byte, and the start slice No. of execution target into the lower byte in hexadecimal as shown below.</p> <p>b15 to b8 b7 to b0</p> <table border="1" style="margin-left: 40px;"> <tr> <td style="width: 80px;">Cr.0(15-8) Command Execution Result</td> <td>Cr.0(7-0) Start Slice No. of Execution Target</td> </tr> </table> <p style="margin-left: 100px;">→ 00H: Normal completion</p>	Cr.0(15-8) Command Execution Result	Cr.0(7-0) Start Slice No. of Execution Target
Cr.0(15-8) Command Execution Result	Cr.0(7-0) Start Slice No. of Execution Target		
Cr.1	The executed command no. is stored. (Hexadecimal)		
Cr.2	The CH□ upper upper limit value is stored. (16-bit signed binary) The range to store the data is from -32768 to 32767.		
Cr.3	The CH□ upper lower limit value is stored. (16-bit signed binary) The range of the stored value is the same as in Cr.2 Response data 1.		

8.3.6 CH□ lower upper/lower lower limit set value read (Command No.: 1309H, 130BH)

Reads the lower upper limit value/ lower lower limit value of the alarm output from the RAM of the ST1TD2.

(1) Values set to **Cw** Command execution area

Cw Command execution area	Setting value
Cw.0	Set the start slice no. of the ST1TD2 where the command will be executed. (Hexadecimal)
Cw.1	CH1 lower upper/ lower lower limit set value read: 1309H CH2 lower upper/ lower lower limit set value read: 130BH
Cw.2	Fixed to 0000H (Any value other than 0000H is ignored.)
Cw.3	

(2) Execution result in **Cr** Command result area

The execution result of the command changes depending on the result (normal completion or abnormal completion) in **Cr.0(15-8)** Command execution result.

(a) Normal completion (When **Cr.0(15-8)** Command execution result is 00H)

Cr Command result area	Result details		
Cr.0	<p>The command execution result is stored into the higher byte, and the start slice No. of execution target into the lower byte in hexadecimal as shown below.</p> <p>b15 to b8 b7 to b0</p> <table border="1" style="margin-left: auto; margin-right: auto;"> <tr> <td style="text-align: center;">Cr.0(15-8) Command Execution Result</td> <td style="text-align: center;">Cr.0(7-0) Start Slice No. of Execution Target</td> </tr> </table> <p style="text-align: center;">→ 00H: Normal completion</p>	Cr.0(15-8) Command Execution Result	Cr.0(7-0) Start Slice No. of Execution Target
Cr.0(15-8) Command Execution Result	Cr.0(7-0) Start Slice No. of Execution Target		
Cr.1	The executed command no. is stored. (Hexadecimal)		
Cr.2	The CH□ lower upper limit value is stored. (16-bit signed binary) The range to store the data is from -32768 to 32767.		
Cr.3	The CH□ lower lower limit value is stored. (16-bit signed binary) The range of the stored value is the same as in Cr.2 Response data 1.		

(b) Abnormal completion (When **Cr.0(15-8)** Command execution result is other than 00H)

Cr Command result area	Result details		
Cr.0	<p>The command execution result is stored into the higher byte, and the start slice No. of execution target into the lower byte in hexadecimal as shown below.</p> <p>b15 to b8 b7 to b0</p> <table border="1" style="margin-left: 40px;"> <tr> <td style="width: 80px;">Cr.0(15-8) Command Execution Result</td> <td style="width: 80px;">Cr.0(7-0) Start Slice No. of Execution Target *1</td> </tr> </table> <p style="margin-left: 120px;"> </p> <p>* 1: When 0FH is stored into the Cr.0(15-8) Command Execution Result, 00H (start slice No. of head module) is stored into the Cr.0(7-0) Start Slice No. of Execution Target.</p>	Cr.0(15-8) Command Execution Result	Cr.0(7-0) Start Slice No. of Execution Target *1
Cr.0(15-8) Command Execution Result	Cr.0(7-0) Start Slice No. of Execution Target *1		
Cr.1	The executed command no. is stored. (Hexadecimal)		
Cr.2	Cw.2 Argument 1 at command execution is stored.		
Cr.3	Cw.3 Argument 2 at command execution is stored.		

8.3.7 User parameter set value read (Command No.: 1318H)

Reads the input type setting, offset/gain value selection and cold junction temperature compensation setting from the RAM of the ST1TD2.

(1) Values set to **Cw** Command execution area

Cw Command execution area	Setting value
Cw.0	Set the start slice no. of the ST1TD2 where the command will be executed. (Hexadecimal)
Cw.1	1318H
Cw.2	Fixed to 0000H (Any value other than 0000H is ignored.)
Cw.3	

(2) Execution result in **Cr** Command result area

The execution result of the command changes depending on the result (normal completion or abnormal completion) in **Cr.0(15-8)** Command execution result.

(a) Normal completion (When **Cr.0(15-8)** Command execution result is 00H)

Cr Command result area	Result details					
Cr.0	<p>The command execution result is stored into the higher byte, and the start slice No. of execution target into the lower byte in hexadecimal as shown below.</p> <p>b15 to b8 b7 to b0</p> <table border="1" style="margin-left: 40px;"> <tr> <td style="width: 80px;">Cr.0(15-8) Command Execution Result</td> <td style="width: 80px;">Cr.0(7-0) Start Slice No. of Execution Target</td> </tr> </table> <p style="margin-left: 100px;">→ 00H: Normal completion</p>	Cr.0(15-8) Command Execution Result	Cr.0(7-0) Start Slice No. of Execution Target			
Cr.0(15-8) Command Execution Result	Cr.0(7-0) Start Slice No. of Execution Target					
Cr.1	The executed command no. is stored. (Hexadecimal)					
Cr.2 *	<p>The input type setting, offset/gain value selection and cold junction temperature compensation setting written to the RAM are stored for each channel.</p> <p>b15 b14 b13 b12 b11 b10 b9 b8 b7 ~ b0</p> <table border="1" style="margin-left: 40px;"> <tr> <td style="width: 40px;">0</td> <td style="width: 40px;">3)</td> <td style="width: 40px;">0</td> <td style="width: 40px;">2)</td> <td style="width: 120px;">1)</td> </tr> </table> <p>1) CH□ input type setting (b0 to b3:CH1, b4 to b7:CH2) 0000 : Thermocouple K 0001 : Thermocouple E 0010 : Thermocouple J 0011 : Thermocouple T 0100 : Thermocouple B 0101 : Thermocouple R 0110 : Thermocouple S 0111 : Thermocouple N 1111 : Micro voltage input</p> <p>2) CH□ offset/gain setting (b8:CH1, b9:CH2) 0 : Factory default 1 : User range setting</p> <p>3) CH□ cold junction temperature compensation setting (b12:CH1, b13:CH2) 0 : Cold junction temperature compensation not performed 1 : Cold junction temperature compensation performed</p>	0	3)	0	2)	1)
0	3)	0	2)	1)		
Cr.3 *	<p>The currently valid input type setting, offset/gain value selection, cold junction temperature compensation setting are stored for each channel.</p> <p>The stored values are the same as those of Cr.2 Response data 1.</p>					

* If the stored values differ between **Cr.2** Response data 1 and **Cr.3** Response data 2, refer to Section 3.4 and take corrective action.

(b) Abnormal completion (When **Cr.0(15-8)** Command execution result is other than 00H)

Cr Command result area	Result details		
Cr.0	<p>The command execution result is stored into the higher byte, and the start slice No. of execution target into the lower byte in hexadecimal as shown below.</p> <p>b15 to b8 b7 to b0</p> <table border="1" style="margin-left: 40px;"> <tr> <td style="width: 80px;">Cr.0(15-8) Command Execution Result</td> <td style="width: 80px;">Cr.0(7-0) Start Slice No. of Execution Target *1</td> </tr> </table> <p style="margin-left: 100px;">→ Other than 00H: Abnormal completion (see Section 8.6)</p> <p>* 1: When 0FH is stored into the Cr.0(15-8) Command Execution Result, 00H (start slice No. of head module) is stored into the Cr.0(7-0) Start Slice No. of Execution Target.</p>	Cr.0(15-8) Command Execution Result	Cr.0(7-0) Start Slice No. of Execution Target *1
Cr.0(15-8) Command Execution Result	Cr.0(7-0) Start Slice No. of Execution Target *1		
Cr.1	The executed command no. is stored. (Hexadecimal)		
Cr.2	Cw.2 Argument 1 at command execution is stored.		
Cr.3	Cw.3 Argument 2 at command execution is stored.		

8.3.8 Sensor compensation value read (Command No.: 131AH)

From the ST1TD2's RAM, reads out a compensation value when an error is identified between "the actual temperature/voltage" and "the measured temperature/voltage".

(1) Values set to **Cw** Command execution area

Cw Command execution area	Setting value
Cw.0	Set the start slice no. of the ST1TD2 where the command will be executed. (Hexadecimal)
Cw.1	131AH
Cw.2	Fixed to 0000H (Any value other than 0000H is ignored.)
Cw.3	

(2) Execution result in **Cr** Command result area

The execution result of the command changes depending on the result (normal completion or abnormal completion) in **Cr.0(15-8)** Command execution result.

(a) Normal completion (When **Cr.0(15-8)** Command execution result is 00H)

Cr Command result area	Result details		
Cr.0	<p>The command execution result is stored into the higher byte, and the start slice No. of execution target into the lower byte in hexadecimal as shown below.</p> <p>b15 to b8 b7 to b0</p> <table border="1" style="margin-left: 40px;"> <tr> <td style="width: 80px;">Cr.0(15-8) Command Execution Result</td> <td>Cr.0(7-0) Start Slice No. of Execution Target</td> </tr> </table> <p style="margin-left: 40px;">} → 00H: Normal completion</p>	Cr.0(15-8) Command Execution Result	Cr.0(7-0) Start Slice No. of Execution Target
Cr.0(15-8) Command Execution Result	Cr.0(7-0) Start Slice No. of Execution Target		
Cr.1	The executed command no. is stored. (Hexadecimal)		
Cr.2	The CH1 sensor compensation value is stored. The range to store the data is from -500 to 500.		
Cr.3	The CH2 sensor compensation value is stored. The range of the stored value is the same as in Cr.2 Response data 1.		

(b) Abnormal completion (When Cr.0(15-8) Command execution result is other than 00H)

Cr Command result area	Result details		
Cr.0	<p>The command execution result is stored into the higher byte, and the start slice No. of execution target into the lower byte in hexadecimal as shown below.</p> <div style="text-align: center; margin-bottom: 10px;"> b15 to b8 b7 to b0 </div> <table border="1" style="margin-left: auto; margin-right: auto; border-collapse: collapse;"> <tr> <td style="text-align: center; padding: 5px;">Cr.0(15-8) Command Execution Result</td> <td style="text-align: center; padding: 5px;">Cr.0(7-0) Start Slice No. of Execution Target *1</td> </tr> </table> <p style="text-align: center; margin-top: 10px;"> } → Other than 00H: Abnormal completion (see Section 8.6) </p> <p>* 1: When 0FH is stored into the Cr.0(15-8) Command Execution Result, 00H (start slice No. of head module) is stored into the Cr.0(7-0) Start Slice No. of Execution Target.</p>	Cr.0(15-8) Command Execution Result	Cr.0(7-0) Start Slice No. of Execution Target *1
Cr.0(15-8) Command Execution Result	Cr.0(7-0) Start Slice No. of Execution Target *1		
Cr.1	The executed command no. is stored. (Hexadecimal)		
Cr.2	Cw.2 Argument 1 at command execution is stored.		
Cr.3	Cw.3 Argument 2 at command execution is stored.		

8.4 ST1TD2 Parameter Setting Write Command

8.4.1 Conversion enable/disable setting write (Command No.: 2300H)

Writes the conversion enable/disable setting to the RAM of the ST1TD2.
 This command can be executed only when $\boxed{Bw.n+1}$ convert setting request is off (0) in the normal mode.

(1) Values set to \boxed{Cw} Command execution area

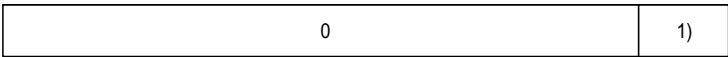
\boxed{Cw} Command execution area	Setting value
$\boxed{Cw.0}$	Set the start slice no. of the ST1TD2 where the command will be executed. (Hexadecimal)
$\boxed{Cw.1}$	2300H
$\boxed{Cw.2}$	Set the conversion enable/disable setting for each channel. b15 to b2 b1 b0  CH \square Conversion enable/disable setting (b0: CH1, b1: CH2) 0: Conversion enable 1: Conversion disable
$\boxed{Cw.3}$	Fixed to 0000H (Any value other than 0000H is ignored.)

(2) Execution result in \boxed{Cr} Command result area

The execution result of the command changes depending on the result (normal completion or abnormal completion) in $\boxed{Cr.0(15-8)}$ Command execution result.

(a) Normal completion (When $\boxed{Cr.0(15-8)}$ Command execution result is 00H)

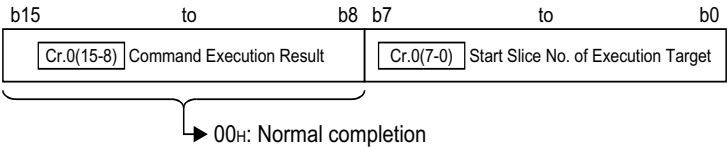
\boxed{Cr} Command result area	Result details
$\boxed{Cr.0}$	The command execution result is stored into the higher byte, and the start slice No. of execution target into the lower byte in hexadecimal as shown below. b15 to b8 b7 to b0 
$\boxed{Cr.1}$	The executed command no. is stored. (Hexadecimal)
$\boxed{Cr.2}$	$\boxed{Cw.2}$ Argument 1 at command execution is stored.
$\boxed{Cr.3}$	0000H

(b) Abnormal completion (When **Cr.0(15-8)** Command execution result is other than 00H)

Cr Command result area	Result details												
Cr.0	<p>The command execution result is stored into the higher byte, and the start slice No. of execution target into the lower byte in hexadecimal as shown below.</p> <div style="text-align: center;"> <table style="margin: auto; border-collapse: collapse;"> <tr> <td style="padding: 0 10px;">b15</td> <td style="padding: 0 10px;">to</td> <td style="padding: 0 10px;">b8</td> <td style="padding: 0 10px;">b7</td> <td style="padding: 0 10px;">to</td> <td style="padding: 0 10px;">b0</td> </tr> <tr> <td colspan="3" style="border: 1px solid black; padding: 2px;">Cr.0(15-8) Command Execution Result</td> <td colspan="3" style="border: 1px solid black; padding: 2px;">Cr.0(7-0) Start Slice No. of Execution Target *1</td> </tr> </table> </div> <p style="text-align: center;"> </p> <p>* 1: When 0FH is stored into the Cr.0(15-8) Command Execution Result, 00H (start slice No. of head module) is stored into the Cr.0(7-0) Start Slice No. of Execution Target.</p>	b15	to	b8	b7	to	b0	Cr.0(15-8) Command Execution Result			Cr.0(7-0) Start Slice No. of Execution Target *1		
b15	to	b8	b7	to	b0								
Cr.0(15-8) Command Execution Result			Cr.0(7-0) Start Slice No. of Execution Target *1										
Cr.1	The executed command no. is stored. (Hexadecimal)												
Cr.2	Cw.2 Argument 1 at command execution is stored.												
Cr.3	Cw.3 Argument 2 at command execution is stored.												

8.4.2 Operation condition set value write (Command No.: 2302H)

Writes the averaging process specification and alarm output setting to the RAM of the ST1TD2.

This command can be executed only when $\boxed{Bw.n+1}$ convert setting request is off (0) in the normal mode.

(1) Values set to \boxed{Cw} Command execution area

\boxed{Cw} Command execution area	Setting value																				
$\boxed{Cw.0}$	Set the start slice no. of the ST1TD2 where the command will be executed. (Hexadecimal)																				
$\boxed{Cw.1}$	2302H																				
$\boxed{Cw.2}$	<p>Specify the channel where sampling process or averaging process will be performed. When averaging process is specified, specify time or number of times.</p> <table border="1"> <tr> <td>b15</td> <td>to</td> <td>b10</td> <td>b9</td> <td>b8</td> <td>b7</td> <td>to</td> <td>b2</td> <td>b1</td> <td>b0</td> </tr> <tr> <td colspan="2">0</td> <td colspan="2">2)</td> <td colspan="2">0</td> <td colspan="2">1)</td> <td colspan="2"></td> </tr> </table> <p>1) Time/number of times specification (b0: CH1, b1: CH2) 0: Number of times averaging 1: Time averaging</p> <p>2) Averaging-processed channel specification (b8: CH1, b9: CH2) 0: Sampling process 1: Averaging process</p>	b15	to	b10	b9	b8	b7	to	b2	b1	b0	0		2)		0		1)			
b15	to	b10	b9	b8	b7	to	b2	b1	b0												
0		2)		0		1)															
$\boxed{Cw.3}$	<p>Specify the channel where alarm output will be executed.</p> <table border="1"> <tr> <td>b15</td> <td>to</td> <td>b2</td> <td>b1</td> <td>b0</td> </tr> <tr> <td colspan="3">0</td> <td colspan="2">1)</td> </tr> </table> <p>1) Alarm output setting (b0: CH1, b1: CH2) 0: Alarm output processing not performed 1: Alarm output processing performed</p>	b15	to	b2	b1	b0	0			1)											
b15	to	b2	b1	b0																	
0			1)																		

(2) Execution result in **Cr** Command result area

The execution result of the command changes depending on the result (normal completion or abnormal completion) in **Cr.0(15-8)** Command execution result.

(a) Normal completion (When **Cr.0(15-8)** Command execution result is 00H)

Cr Command result area	Result details		
Cr.0	<p>The command execution result is stored into the higher byte, and the start slice No. of execution target into the lower byte in hexadecimal as shown below.</p> <p>b15 to b8 b7 to b0</p> <table border="1" style="margin-left: 40px;"> <tr> <td style="width: 80px;">Cr.0(15-8) Command Execution Result</td> <td style="width: 80px;">Cr.0(7-0) Start Slice No. of Execution Target</td> </tr> </table> <p style="margin-left: 100px;">→ 00H: Normal completion</p>	Cr.0(15-8) Command Execution Result	Cr.0(7-0) Start Slice No. of Execution Target
Cr.0(15-8) Command Execution Result	Cr.0(7-0) Start Slice No. of Execution Target		
Cr.1	The executed command no. is stored. (Hexadecimal)		
Cr.2	0000H		
Cr.3			

(b) Abnormal completion (When **Cr.0(15-8)** Command execution result is other than 00H)

Cr Command result area	Result details		
Cr.0	<p>The command execution result is stored into the higher byte, and the start slice No. of execution target into the lower byte in hexadecimal as shown below.</p> <p>b15 to b8 b7 to b0</p> <table border="1" style="margin-left: 40px;"> <tr> <td style="width: 80px;">Cr.0(15-8) Command Execution Result</td> <td style="width: 80px;">Cr.0(7-0) Start Slice No. of Execution Target *1</td> </tr> </table> <p style="margin-left: 100px;">→ Other than 00H: Abnormal completion (see Section 8.6)</p> <p>*1: When 0FH is stored into the Cr.0(15-8) Command Execution Result, 00H (start slice No. of head module) is stored into the Cr.0(7-0) Start Slice No. of Execution Target.</p>	Cr.0(15-8) Command Execution Result	Cr.0(7-0) Start Slice No. of Execution Target *1
Cr.0(15-8) Command Execution Result	Cr.0(7-0) Start Slice No. of Execution Target *1		
Cr.1	The executed command no. is stored. (Hexadecimal)		
Cr.2	Cw.2 Argument 1 at command execution is stored.		
Cr.3	Cw.3 Argument 2 at command execution is stored.		

8.4.3 CH□ average time/average number of times set value write (Command No.: 2304H)

Writes the set number of times or time amount of the averaging processing to the RAM of the ST1TD2.

This command can be executed only when **[Bw.n+1]** convert setting request is off (0) in the normal mode.

(1) Values set to **[Cw]** Command execution area

[Cw] Command execution area	Setting value
[Cw.0]	Set the start slice no. of the ST1TD2 where the command will be executed. (Hexadecimal)
[Cw.1]	2304H
[Cw.2]	Set the number of times or time of the averaging process for channel 1. The value in the following range is stored. The averaging process by the number of times: 4 to 500 (times). The averaging processing by the time: 480 to 5000 (ms).
[Cw.3]	Set the number of times or time of the averaging process for channel 2. The setting range is the same as in [Cw.2] Argument 1.

(2) Execution result in **[Cr]** Command result area

The execution result of the command changes depending on the result (normal completion or abnormal completion) in **[Cr.0(15-8)]** Command execution result.

(a) Normal completion (When **[Cr.0(15-8)]** Command execution result is 00H)

[Cr] Command result area	Result details
[Cr.0]	The command execution result is stored into the higher byte, and the start slice No. of execution target into the lower byte in hexadecimal as shown below. <div style="display: flex; justify-content: space-around; align-items: center;"> b15 to b8 b7 to b0 </div> <div style="display: flex; justify-content: space-around; align-items: center; margin-top: 5px;"> <div style="border: 1px solid black; padding: 2px;"> [Cr.0(15-8)] Command Execution Result </div> <div style="border: 1px solid black; padding: 2px;"> [Cr.0(7-0)] Start Slice No. of Execution Target </div> </div> <div style="margin-top: 5px;"> } → 00H: Normal completion </div>
[Cr.1]	The executed command no. is stored. (Hexadecimal)
[Cr.2]	0000H
[Cr.3]	

8.4.4 CH□ upper upper/upper lower limit set value write (Command No.: 2308H, 230AH)

Writes the upper upper limit value/upper lower limit value to the RAM of the ST1TD2. This command can be executed only when **[Bw.n+1]** convert setting request is off (0) in the normal mode.

(1) Values set to **[Cw]** Command execution area

[Cw] Command execution area	Setting value																				
[Cw.0]	Set the start slice no. of the ST1TD2 where the command will be executed. (Hexadecimal)																				
[Cw.1]	CH1 upper upper/upper lower limit set value write: 2308H CH2 upper upper/upper lower limit set value write: 230AH																				
[Cw.2]	<p>Set the upper upper limit value of the alarm output. Setting range on each input type is shown below. Setting of thermocouple input is in 0.1°C unit. [Example] To set to 0.3°C ...Store 3.</p> <table border="1"> <thead> <tr> <th>Input type</th> <th>Setting range (Accuracy guarantee range)</th> </tr> </thead> <tbody> <tr> <td>Thermocouple K</td> <td>-2700 to 13720 (-2000 to 12000)</td> </tr> <tr> <td>Thermocouple E</td> <td>-2700 to 10000 (-2000 to 9000)</td> </tr> <tr> <td>Thermocouple J</td> <td>-2100 to 12000 (-400 to 7500)</td> </tr> <tr> <td>Thermocouple T</td> <td>-2700 to 4000 (-2000 to 3500)</td> </tr> <tr> <td>Thermocouple B</td> <td>0 to 18200 (6000 to 17000)</td> </tr> <tr> <td>Thermocouple R</td> <td>-500 to 17680 (0 to 16000)</td> </tr> <tr> <td>Thermocouple S</td> <td>-500 to 17680 (0 to 16000)</td> </tr> <tr> <td>Thermocouple N</td> <td>-2700 to 13000 (-2000 to 12500)</td> </tr> <tr> <td>Micro voltage input</td> <td>-21000 to 21000 (-20000 to 20000)</td> </tr> </tbody> </table> <p>Make setting to satisfy the condition of upper upper value ≥ upper lower value ≥ lower upper value ≥ lower lower value.</p>	Input type	Setting range (Accuracy guarantee range)	Thermocouple K	-2700 to 13720 (-2000 to 12000)	Thermocouple E	-2700 to 10000 (-2000 to 9000)	Thermocouple J	-2100 to 12000 (-400 to 7500)	Thermocouple T	-2700 to 4000 (-2000 to 3500)	Thermocouple B	0 to 18200 (6000 to 17000)	Thermocouple R	-500 to 17680 (0 to 16000)	Thermocouple S	-500 to 17680 (0 to 16000)	Thermocouple N	-2700 to 13000 (-2000 to 12500)	Micro voltage input	-21000 to 21000 (-20000 to 20000)
Input type	Setting range (Accuracy guarantee range)																				
Thermocouple K	-2700 to 13720 (-2000 to 12000)																				
Thermocouple E	-2700 to 10000 (-2000 to 9000)																				
Thermocouple J	-2100 to 12000 (-400 to 7500)																				
Thermocouple T	-2700 to 4000 (-2000 to 3500)																				
Thermocouple B	0 to 18200 (6000 to 17000)																				
Thermocouple R	-500 to 17680 (0 to 16000)																				
Thermocouple S	-500 to 17680 (0 to 16000)																				
Thermocouple N	-2700 to 13000 (-2000 to 12500)																				
Micro voltage input	-21000 to 21000 (-20000 to 20000)																				
[Cw.3]	Set the upper lower limit value of the alarm output. The setting range is the same as in [Cw.2] Argument 1																				

(2) Execution result in **[Cr]** Command result area

The execution result of the command changes depending on the result (normal completion or abnormal completion) in **[Cr.0(15-8)]** Command execution result.

(a) Normal completion (When **[Cr.0(15-8)]** Command execution result is 00H)

[Cr] Command result area	Result details												
[Cr.0]	<p>The command execution result is stored into the higher byte, and the start slice No. of execution target into the lower byte in hexadecimal as shown below.</p> <table border="1"> <tr> <td>b15</td> <td>to</td> <td>b8</td> <td>b7</td> <td>to</td> <td>b0</td> </tr> <tr> <td colspan="3">[Cr.0(15-8)] Command Execution Result</td> <td colspan="3">[Cr.0(7-0)] Start Slice No. of Execution Target</td> </tr> </table> <p>→ 00H: Normal completion</p>	b15	to	b8	b7	to	b0	[Cr.0(15-8)] Command Execution Result			[Cr.0(7-0)] Start Slice No. of Execution Target		
b15	to	b8	b7	to	b0								
[Cr.0(15-8)] Command Execution Result			[Cr.0(7-0)] Start Slice No. of Execution Target										
[Cr.1]	The executed command no. is stored. (Hexadecimal)												
[Cr.2]	0000H												
[Cr.3]													

(b) Abnormal completion (When **Cr.0(15-8)** Command execution result is other than 00H)

Cr Command result area	Result details		
Cr.0	<p>The command execution result is stored into the higher byte, and the start slice No. of execution target into the lower byte in hexadecimal as shown below.</p> <p>b15 to b8 b7 to b0</p> <table border="1" style="margin-left: auto; margin-right: auto;"> <tr> <td style="text-align: center;">Cr.0(15-8) Command Execution Result</td> <td style="text-align: center;">Cr.0(7-0) Start Slice No. of Execution Target *1</td> </tr> </table> <p style="text-align: center;"> Other than 00H: Abnormal completion (see Section 8.6) </p> <p>* 1: When 0FH is stored into the Cr.0(15-8) Command Execution Result, 00H (start slice No. of head module) is stored into the Cr.0(7-0) Start Slice No. of Execution Target.</p>	Cr.0(15-8) Command Execution Result	Cr.0(7-0) Start Slice No. of Execution Target *1
Cr.0(15-8) Command Execution Result	Cr.0(7-0) Start Slice No. of Execution Target *1		
Cr.1	The executed command no. is stored. (Hexadecimal)		
Cr.2	Cw.2 Argument 1 at command execution is stored.		
Cr.3	Cw.3 Argument 2 at command execution is stored.		

8.4.5 CH□ lower upper/ lower lower limit set value write (Command No.: 2309H, 230BH)

Writes the lower upper limit value/lower lower limit value to the RAM of the ST1TD2. This command can be executed only when **Bw.n+1** convert setting request is off (0) in the normal mode.

(1) Values set to **Cw** Command execution area

Cw Command execution area	Setting value																				
Cw.0	Set the start slice no. of the ST1TD2 where the command will be executed. (Hexadecimal)																				
Cw.1	CH1 lower upper/ lower lower limit set value write: 2309H CH2 lower upper/ lower lower limit set value write: 230BH																				
Cw.2	<p>Set the lower upper limit value of the alarm output. Setting range on each input type is shown below. Setting of thermocouple input is in 0.1°C unit. [Example] To set to 0.3°C ...Store 3.</p> <table border="1"> <thead> <tr> <th>Input type</th> <th>Setting range (Accuracy guarantee range)</th> </tr> </thead> <tbody> <tr> <td>Thermocouple K</td> <td>-2700 to 13720 (-2000 to 12000)</td> </tr> <tr> <td>Thermocouple E</td> <td>-2700 to 10000 (-2000 to 9000)</td> </tr> <tr> <td>Thermocouple J</td> <td>-2100 to 12000 (-400 to 7500)</td> </tr> <tr> <td>Thermocouple T</td> <td>-2700 to 4000 (-2000 to 3500)</td> </tr> <tr> <td>Thermocouple B</td> <td>0 to 18200 (6000 to 17000)</td> </tr> <tr> <td>Thermocouple R</td> <td>-500 to 17680 (0 to 16000)</td> </tr> <tr> <td>Thermocouple S</td> <td>-500 to 17680 (0 to 16000)</td> </tr> <tr> <td>Thermocouple N</td> <td>-2700 to 13000 (-2000 to 12500)</td> </tr> <tr> <td>Micro voltage input</td> <td>-21000 to 21000 (-20000 to 20000)</td> </tr> </tbody> </table> <p>Make setting to satisfy the condition of upper upper value ≥ upper lower value ≥ lower upper value ≥ lower lower value.</p>	Input type	Setting range (Accuracy guarantee range)	Thermocouple K	-2700 to 13720 (-2000 to 12000)	Thermocouple E	-2700 to 10000 (-2000 to 9000)	Thermocouple J	-2100 to 12000 (-400 to 7500)	Thermocouple T	-2700 to 4000 (-2000 to 3500)	Thermocouple B	0 to 18200 (6000 to 17000)	Thermocouple R	-500 to 17680 (0 to 16000)	Thermocouple S	-500 to 17680 (0 to 16000)	Thermocouple N	-2700 to 13000 (-2000 to 12500)	Micro voltage input	-21000 to 21000 (-20000 to 20000)
Input type	Setting range (Accuracy guarantee range)																				
Thermocouple K	-2700 to 13720 (-2000 to 12000)																				
Thermocouple E	-2700 to 10000 (-2000 to 9000)																				
Thermocouple J	-2100 to 12000 (-400 to 7500)																				
Thermocouple T	-2700 to 4000 (-2000 to 3500)																				
Thermocouple B	0 to 18200 (6000 to 17000)																				
Thermocouple R	-500 to 17680 (0 to 16000)																				
Thermocouple S	-500 to 17680 (0 to 16000)																				
Thermocouple N	-2700 to 13000 (-2000 to 12500)																				
Micro voltage input	-21000 to 21000 (-20000 to 20000)																				
Cw.3	Set the lower lower limit value of the alarm output. The setting range is the same as in Cw.2 Argument 1																				

(2) Execution result in **Cr** Command result area

The execution result of the command changes depending on the result (normal completion or abnormal completion) in **Cr.0(15-8)** Command execution result.

(a) Normal completion (When **Cr.0(15-8)** Command execution result is 00H)

Cr Command result area	Result details												
Cr.0	<p>The command execution result is stored into the higher byte, and the start slice No. of execution target into the lower byte in hexadecimal as shown below.</p> <table border="1"> <tr> <td>b15</td> <td>to</td> <td>b8</td> <td>b7</td> <td>to</td> <td>b0</td> </tr> <tr> <td colspan="3">Cr.0(15-8) Command Execution Result</td> <td colspan="3">Cr.0(7-0) Start Slice No. of Execution Target</td> </tr> </table> <p>→ 00H: Normal completion</p>	b15	to	b8	b7	to	b0	Cr.0(15-8) Command Execution Result			Cr.0(7-0) Start Slice No. of Execution Target		
b15	to	b8	b7	to	b0								
Cr.0(15-8) Command Execution Result			Cr.0(7-0) Start Slice No. of Execution Target										
Cr.1	The executed command no. is stored. (Hexadecimal)												
Cr.2	0000H												
Cr.3													

8.4.6 Sensor compensation value write (Command No.: 231AH)

Writes a compensation value to the ST1TD2's RAM when an error is identified between "the actual temperature/voltage" and "the measured temperature/voltage".

(1) Values set to **Cw** Command execution area

Cw Command execution area	Setting value
Cw.0	Set the start slice no. of the ST1TD2 where the command will be executed. (Hexadecimal)
Cw.1	231AH
Cw.2	Set the sensor compensation value for channel 1. Setting of thermocouple input is in 0.1°C unit. [Example] To set to 0.3°C ...Enter "3". Setting of micro voltage input is in 4μV /digits unit. [Example] When the micro voltage conversion value is 10003 at 40mV input ... Enter "-3". The setting range is -500 to 500.
Cw.3	Set the sensor compensation value for channel 2. The setting range is the same as in Cw.2 Argument 1

(2) Execution result in **Cr** Command result area

The execution result of the command changes depending on the result (normal completion or abnormal completion) in **Cr.0(15-8)** Command execution result.

(a) Normal completion (When **Cr.0(15-8)** Command execution result is 00H)

Cr Command result area	Result details		
Cr.0	<p>The command execution result is stored into the higher byte, and the start slice No. of execution target into the lower byte in hexadecimal as shown below.</p> <p>b15 to b8 b7 to b0</p> <table border="1" style="margin-left: 40px;"> <tr> <td style="width: 80px;">Cr.0(15-8) Command Execution Result</td> <td style="width: 80px;">Cr.0(7-0) Start Slice No. of Execution Target</td> </tr> </table> <p style="margin-left: 40px;">} → 00H: Normal completion</p>	Cr.0(15-8) Command Execution Result	Cr.0(7-0) Start Slice No. of Execution Target
Cr.0(15-8) Command Execution Result	Cr.0(7-0) Start Slice No. of Execution Target		
Cr.1	The executed command no. is stored. (Hexadecimal)		
Cr.2	0000H		
Cr.3			

(b) Abnormal completion (When **Cr.0(15-8)** Command execution result is other than 00H)

Cr Command result area	Result details												
Cr.0	<p>The command execution result is stored into the higher byte, and the start slice No. of execution target into the lower byte in hexadecimal as shown below.</p> <div style="text-align: center;"> <table style="margin: auto; border-collapse: collapse;"> <tr> <td style="padding: 0 10px;">b15</td> <td style="padding: 0 10px;">to</td> <td style="padding: 0 10px;">b8</td> <td style="padding: 0 10px;">b7</td> <td style="padding: 0 10px;">to</td> <td style="padding: 0 10px;">b0</td> </tr> <tr> <td colspan="3" style="border: 1px solid black; padding: 2px;">Cr.0(15-8) Command Execution Result</td> <td colspan="3" style="border: 1px solid black; padding: 2px;">Cr.0(7-0) Start Slice No. of Execution Target *1</td> </tr> </table> </div> <p style="text-align: center;">  Other than 00H: Abnormal completion (see Section 8.6) </p> <p>* 1: When 0FH is stored into the Cr.0(15-8) Command Execution Result, 00H (start slice No. of head module) is stored into the Cr.0(7-0) Start Slice No. of Execution Target.</p>	b15	to	b8	b7	to	b0	Cr.0(15-8) Command Execution Result			Cr.0(7-0) Start Slice No. of Execution Target *1		
b15	to	b8	b7	to	b0								
Cr.0(15-8) Command Execution Result			Cr.0(7-0) Start Slice No. of Execution Target *1										
Cr.1	The executed command no. is stored. (Hexadecimal)												
Cr.2	Cw.2 Argument 1 at command execution is stored.												
Cr.3	Cw.3 Argument 2 at command execution is stored.												

8.5 ST1TD2 Control Command

8.5.1 Parameter setting ROM read (Command No.: 3300H)

Reads the parameters from the ROM of the ST1TD2 to the RAM.

This command can be executed only when **[Bw.n+1]** convert setting request is off (0) in the normal mode.

(1) Values set to **[Cw]** Command execution area

[Cw] Command execution area	Setting value
[Cw.0]	Set the start slice no. of the ST1TD2 where the command will be executed. (Hexadecimal)
[Cw.1]	3300H
[Cw.2]	Fixed to 0000H (Any value other than 0000H is ignored.)
[Cw.3]	

(2) Execution result in **[Cr]** Command result area

The execution result of the command changes depending on the result (normal completion or abnormal completion) in **[Cr.0(15-8)]** Command execution result.

(a) Normal completion (When **[Cr.0(15-8)]** Command execution result is 00H)

[Cr] Command result area	Result details												
[Cr.0]	<p>The command execution result is stored into the higher byte, and the start slice No. of execution target into the lower byte in hexadecimal as shown below.</p> <table border="1" style="margin-left: 40px;"> <tr> <td style="text-align: center;">b15</td> <td style="text-align: center;">to</td> <td style="text-align: center;">b8</td> <td style="text-align: center;">b7</td> <td style="text-align: center;">to</td> <td style="text-align: center;">b0</td> </tr> <tr> <td colspan="3" style="text-align: center;">[Cr.0(15-8)] Command Execution Result</td> <td colspan="3" style="text-align: center;">[Cr.0(7-0)] Start Slice No. of Execution Target</td> </tr> </table> <p style="margin-left: 100px;">→ 00H: Normal completion</p>	b15	to	b8	b7	to	b0	[Cr.0(15-8)] Command Execution Result			[Cr.0(7-0)] Start Slice No. of Execution Target		
b15	to	b8	b7	to	b0								
[Cr.0(15-8)] Command Execution Result			[Cr.0(7-0)] Start Slice No. of Execution Target										
[Cr.1]	The executed command no. is stored. (Hexadecimal)												
[Cr.2]	0000H												
[Cr.3]													

(b) Abnormal completion (When **[Cr.0(15-8)]** Command execution result is other than 00H)

[Cr] Command result area	Result details												
[Cr.0]	<p>The command execution result is stored into the higher byte, and the start slice No. of execution target into the lower byte in hexadecimal as shown below.</p> <table border="1" style="margin-left: 40px;"> <tr> <td style="text-align: center;">b15</td> <td style="text-align: center;">to</td> <td style="text-align: center;">b8</td> <td style="text-align: center;">b7</td> <td style="text-align: center;">to</td> <td style="text-align: center;">b0</td> </tr> <tr> <td colspan="3" style="text-align: center;">[Cr.0(15-8)] Command Execution Result</td> <td colspan="3" style="text-align: center;">[Cr.0(7-0)] Start Slice No. of Execution Target *1</td> </tr> </table> <p style="margin-left: 100px;">→ Other than 00H: Abnormal completion (see Section 8.6)</p> <p>*1: When 0FH is stored into the [Cr.0(15-8)] Command Execution Result, 00H (start slice No. of head module) is stored into the [Cr.0(7-0)] Start Slice No. of Execution Target.</p>	b15	to	b8	b7	to	b0	[Cr.0(15-8)] Command Execution Result			[Cr.0(7-0)] Start Slice No. of Execution Target *1		
b15	to	b8	b7	to	b0								
[Cr.0(15-8)] Command Execution Result			[Cr.0(7-0)] Start Slice No. of Execution Target *1										
[Cr.1]	The executed command no. is stored. (Hexadecimal)												
[Cr.2]	[Cw.2] Argument 1 at command execution is stored.												
[Cr.3]	[Cw.3] Argument 2 at command execution is stored.												

8.5.2 Parameter setting ROM write (Command No.: 3301H)

Writes the parameters from the RAM of the ST1TD2 to the ROM.

This command can be executed only when Bw.n+1 convert setting request is off (0) in the normal mode.

(1) Values set to Cw Command execution area

Cw Command execution area	Setting value
Cw.0	Set the start slice no. of the ST1TD2 where the command will be executed. (Hexadecimal)
Cw.1	3301H
Cw.2	Fixed to 0000H (Any value other than 0000H is ignored.)
Cw.3	

(2) Execution result in Cr Command result area

The execution result of the command changes depending on the result (normal completion or completion) in Cr.0(15-8) Command execution result.

(a) Normal completion (When Cr.0(15-8) Command execution result is 00H)

Cr Command result area	Result details		
Cr.0	<p>The command execution result is stored into the higher byte, and the start slice No. of execution target into the lower byte in hexadecimal as shown below.</p> <p>b15 to b8 b7 to b0</p> <table border="1" style="margin-left: auto; margin-right: auto;"> <tr> <td style="text-align: center;">Cr.0(15-8) Command Execution Result</td> <td style="text-align: center;">Cr.0(7-0) Start Slice No. of Execution Target</td> </tr> </table> <p style="text-align: center;">→ 00H: Normal completion</p>	Cr.0(15-8) Command Execution Result	Cr.0(7-0) Start Slice No. of Execution Target
Cr.0(15-8) Command Execution Result	Cr.0(7-0) Start Slice No. of Execution Target		
Cr.1	The executed command no. is stored. (Hexadecimal)		
Cr.2	0000H		
Cr.3			

(b) Abnormal completion (When **Cr.0(15-8)** Command execution result is other than 00H)

Cr Command result area	Result details		
Cr.0	<p>The command execution result is stored into the higher byte, and the start slice No. of execution target into the lower byte in hexadecimal as shown below.</p> <p>b15 to b8 b7 to b0</p> <table border="1" style="margin-left: auto; margin-right: auto;"> <tr> <td style="text-align: center;">Cr.0(15-8) Command Execution Result</td> <td style="text-align: center;">Cr.0(7-0) Start Slice No. of Execution Target *1</td> </tr> </table> <p style="text-align: center;"> </p> <p>* 1: When 0FH is stored into the Cr.0(15-8) Command Execution Result, 00H (start slice No. of head module) is stored into the Cr.0(7-0) Start Slice No. of Execution Target.</p>	Cr.0(15-8) Command Execution Result	Cr.0(7-0) Start Slice No. of Execution Target *1
Cr.0(15-8) Command Execution Result	Cr.0(7-0) Start Slice No. of Execution Target *1		
Cr.1	The executed command no. is stored. (Hexadecimal)		
Cr.2	Cw.2 Argument 1 at command execution is stored.		
Cr.3	Cw.3 Argument 2 at command execution is stored.		

POINT

Execute Parameter setting ROM write (command number: 3301H) after confirming that normal operation is performed with the settings written to the RAM.

8.5.3 Operation mode setting (Command No.: 3302H)

Changes the mode of the ST1TD2. (Normal mode to offset/gain setting mode, offset/gain setting mode to normal mode)

This command can be executed when $\boxed{\text{Bw.n+1}}$ convert setting request is off (0) in the normal mode or when the module is in the offset/gain setting mode.

(1) Values set to $\boxed{\text{Cw}}$ Command execution area

$\boxed{\text{Cw}}$ Command execution area	Setting value
$\boxed{\text{Cw.0}}$	Set the start slice no. of the ST1TD2 where the command will be executed. (Hexadecimal)
$\boxed{\text{Cw.1}}$	3302H
$\boxed{\text{Cw.2}}$	Set the operation mode. 0000H : Normal mode 0001H : Offset/gain setting mode
$\boxed{\text{Cw.3}}$	Fixed to 0000H (Any value other than 0000H is ignored.)

(2) Execution result in $\boxed{\text{Cr}}$ Command result area

The execution result of the command changes depending on the result (normal completion or abnormal completion) in $\boxed{\text{Cr.0(15-8)}}$ Command execution result.

(a) Normal completion (When $\boxed{\text{Cr.0(15-8)}}$ Command execution result is 00H)

$\boxed{\text{Cr}}$ Command result area	Result details		
$\boxed{\text{Cr.0}}$	<p>The command execution result is stored into the higher byte, and the start slice No. of execution target into the lower byte in hexadecimal as shown below.</p> <p>b15 to b8 b7 to b0</p> <table border="1" style="margin-left: 40px;"> <tr> <td style="width: 80px;">$\boxed{\text{Cr.0(15-8)}}$ Command Execution Result</td> <td style="width: 80px;">$\boxed{\text{Cr.0(7-0)}}$ Start Slice No. of Execution Target</td> </tr> </table> <p style="margin-left: 40px;">} → 00H: Normal completion</p>	$\boxed{\text{Cr.0(15-8)}}$ Command Execution Result	$\boxed{\text{Cr.0(7-0)}}$ Start Slice No. of Execution Target
$\boxed{\text{Cr.0(15-8)}}$ Command Execution Result	$\boxed{\text{Cr.0(7-0)}}$ Start Slice No. of Execution Target		
$\boxed{\text{Cr.1}}$	The executed command no. is stored. (Hexadecimal)		
$\boxed{\text{Cr.2}}$	$\boxed{\text{Cw.2}}$ Argument 1 at command execution is stored.		
$\boxed{\text{Cr.3}}$	0000H		

(b) Abnormal completion (When **Cr.0(15-8)** Command execution result is other than 00H)

Cr Command result area	Result details												
Cr.0	<p>The command execution result is stored into the higher byte, and the start slice No. of execution target into the lower byte in hexadecimal as shown below.</p> <div style="text-align: center;"> <table style="margin: auto; border-collapse: collapse;"> <tr> <td style="padding: 0 10px;">b15</td> <td style="padding: 0 10px;">to</td> <td style="padding: 0 10px;">b8</td> <td style="padding: 0 10px;">b7</td> <td style="padding: 0 10px;">to</td> <td style="padding: 0 10px;">b0</td> </tr> <tr> <td colspan="3" style="border: 1px solid black; padding: 2px;">Cr.0(15-8) Command Execution Result</td> <td colspan="3" style="border: 1px solid black; padding: 2px;">Cr.0(7-0) Start Slice No. of Execution Target *1</td> </tr> </table> </div> <p style="text-align: center;">  Other than 00H: Abnormal completion (see Section 8.6) </p> <p>* 1: When 0FH is stored into the Cr.0(15-8) Command Execution Result, 00H (start slice No. of head module) is stored into the Cr.0(7-0) Start Slice No. of Execution Target.</p>	b15	to	b8	b7	to	b0	Cr.0(15-8) Command Execution Result			Cr.0(7-0) Start Slice No. of Execution Target *1		
b15	to	b8	b7	to	b0								
Cr.0(15-8) Command Execution Result			Cr.0(7-0) Start Slice No. of Execution Target *1										
Cr.1	The executed command no. is stored. (Hexadecimal)												
Cr.2	Cw.2 Argument 1 at command execution is stored.												
Cr.3	Cw.3 Argument 2 at command execution is stored.												

8.5.4 Offset channel specification (Command No.: 3303H)

Specify the channel where the offset value will be adjusted.
 When this command is executed, the value given to ST1TD2 is written in RAM as the offset value.
 This command can be executed only in the offset/gain setting mode.

(1) Values set to **Cw** Command execution area

Cw Command execution area	Setting value																				
Cw.0	Set the start slice no. of the ST1TD2 where the command will be executed. (Hexadecimal)																				
Cw.1	3303H																				
Cw.2	Specify the channel where the offset value of offset/gain setting will be adjusted. Values can be set to multiple channels at a time. b15 to b2 b1 b0 <table border="1" data-bbox="502 891 1233 947"> <tr> <td style="width: 100px; text-align: center;">0</td> <td style="width: 20px; text-align: center;">1)</td> </tr> </table> 1) Offset channel specification (b0: CH, b1: CH2) 0: Invalid 1: Channel to set	0	1)																		
0	1)																				
Cw.3	Set the acceptable temperature setting value and/or voltage setting value for input. • The temperature setting value is set in the unit of 0.1°C. [Example] To set to 0.3°C ...Store 3. • The voltage setting range is set in the unit of 0.01mV. [Example] To set to 3mV...Store 300. Setting range on each input type is shown below. <table border="1" data-bbox="512 1303 1256 1621"> <thead> <tr> <th>Input type</th> <th>Setting range (Accuracy guarantee range)</th> </tr> </thead> <tbody> <tr> <td>Thermocouple K</td> <td>-2700 to 13720 (-2000 to 12000)</td> </tr> <tr> <td>Thermocouple E</td> <td>-2700 to 10000 (-2000 to 9000)</td> </tr> <tr> <td>Thermocouple J</td> <td>-2100 to 12000 (-400 to 7500)</td> </tr> <tr> <td>Thermocouple T</td> <td>-2700 to 4000 (-2000 to 3500)</td> </tr> <tr> <td>Thermocouple B</td> <td>0 to 18200 (6000 to 17000)</td> </tr> <tr> <td>Thermocouple R</td> <td>-500 to 17680 (0 to 16000)</td> </tr> <tr> <td>Thermocouple S</td> <td>-500 to 17680 (0 to 16000)</td> </tr> <tr> <td>Thermocouple N</td> <td>-2700 to 13000 (-2000 to 12500)</td> </tr> <tr> <td>Micro voltage input</td> <td>-8000 to 8000 (-8000 to 8000)</td> </tr> </tbody> </table>	Input type	Setting range (Accuracy guarantee range)	Thermocouple K	-2700 to 13720 (-2000 to 12000)	Thermocouple E	-2700 to 10000 (-2000 to 9000)	Thermocouple J	-2100 to 12000 (-400 to 7500)	Thermocouple T	-2700 to 4000 (-2000 to 3500)	Thermocouple B	0 to 18200 (6000 to 17000)	Thermocouple R	-500 to 17680 (0 to 16000)	Thermocouple S	-500 to 17680 (0 to 16000)	Thermocouple N	-2700 to 13000 (-2000 to 12500)	Micro voltage input	-8000 to 8000 (-8000 to 8000)
Input type	Setting range (Accuracy guarantee range)																				
Thermocouple K	-2700 to 13720 (-2000 to 12000)																				
Thermocouple E	-2700 to 10000 (-2000 to 9000)																				
Thermocouple J	-2100 to 12000 (-400 to 7500)																				
Thermocouple T	-2700 to 4000 (-2000 to 3500)																				
Thermocouple B	0 to 18200 (6000 to 17000)																				
Thermocouple R	-500 to 17680 (0 to 16000)																				
Thermocouple S	-500 to 17680 (0 to 16000)																				
Thermocouple N	-2700 to 13000 (-2000 to 12500)																				
Micro voltage input	-8000 to 8000 (-8000 to 8000)																				

(2) Execution result in **Cr** Command result area

The execution result of the command changes depending on the result (normal completion or abnormal completion) in **Cr.0(15-8)** Command execution result.

(a) Normal completion (When **Cr.0(15-8)** Command execution result is 00H)

Cr Command result area	Result details		
Cr.0	<p>The command execution result is stored into the higher byte, and the start slice No. of execution target into the lower byte in hexadecimal as shown below.</p> <p>b15 to b8 b7 to b0</p> <table border="1" style="margin-left: 40px;"> <tr> <td style="width: 80px;">Cr.0(15-8) Command Execution Result</td> <td style="width: 80px;">Cr.0(7-0) Start Slice No. of Execution Target</td> </tr> </table> <p style="margin-left: 100px;">→ 00H: Normal completion</p>	Cr.0(15-8) Command Execution Result	Cr.0(7-0) Start Slice No. of Execution Target
Cr.0(15-8) Command Execution Result	Cr.0(7-0) Start Slice No. of Execution Target		
Cr.1	The executed command no. is stored. (Hexadecimal)		
Cr.2	0000H		
Cr.3			

(b) Abnormal completion (When **Cr.0(15-8)** Command execution result is other than 00H)

Cr Command result area	Result details		
Cr.0	<p>The command execution result is stored into the higher byte, and the start slice No. of execution target into the lower byte in hexadecimal as shown below.</p> <p>b15 to b8 b7 to b0</p> <table border="1" style="margin-left: 40px;"> <tr> <td style="width: 80px;">Cr.0(15-8) Command Execution Result</td> <td style="width: 80px;">Cr.0(7-0) Start Slice No. of Execution Target *1</td> </tr> </table> <p style="margin-left: 100px;">→ Other than 00H: Abnormal completion (see Section 8.6)</p> <p>*1: When 0FH is stored into the Cr.0(15-8) Command Execution Result, 00H (start slice No. of head module) is stored into the Cr.0(7-0) Start Slice No. of Execution Target.</p>	Cr.0(15-8) Command Execution Result	Cr.0(7-0) Start Slice No. of Execution Target *1
Cr.0(15-8) Command Execution Result	Cr.0(7-0) Start Slice No. of Execution Target *1		
Cr.1	The executed command no. is stored. (Hexadecimal)		
Cr.2	Cw.2 Argument 1 at command execution is stored.		
Cr.3	Cw.3 Argument 2 at command execution is stored.		

8.5.5 Gain channel specification (Command No.: 3304H)

Specify the channel where the gain value will be adjusted.

When this command is executed, the value given to ST1TD2 is written in RAM as the gain value.

This command can be executed only in the offset/gain setting mode.

(1) Values set to **Cw** Command execution area

Cw Command execution area	Setting value																				
Cw.0	Set the start slice no. of the ST1TD2 where the command will be executed. (Hexadecimal)																				
Cw.1	3304H																				
Cw.2	<p>Specify the channel where the gain value of offset/gain setting will be adjusted. Values can be set to multiple channels at a time.</p> <table border="1" data-bbox="502 869 1236 945"> <tr> <td style="text-align: right;">b15</td> <td style="text-align: center;">to</td> <td style="text-align: left;">b2</td> <td style="text-align: left;">b1</td> <td style="text-align: left;">b0</td> </tr> <tr> <td colspan="3" style="text-align: center;">0</td> <td colspan="2" style="text-align: center;">1)</td> </tr> </table> <p>1) Gain channel specification (b0: CH1, b1: CH2) 0: Invalid 1: Channel to set</p>	b15	to	b2	b1	b0	0			1)											
b15	to	b2	b1	b0																	
0			1)																		
Cw.3	<p>Set the acceptable temperature setting value and/or voltage setting value for input.</p> <ul style="list-style-type: none"> The temperature setting value is set in the unit of 0.1°C. [Example] To set to 0.3°C ...Store 3. The voltage setting range is set in the unit of 0.01mV. [Example] To set to 3mV...Store 300. <p>Setting range on each input type is shown below.</p> <table border="1" data-bbox="510 1303 1257 1621"> <thead> <tr> <th>Input type</th> <th>Setting range (Accuracy guarantee range)</th> </tr> </thead> <tbody> <tr> <td>Thermocouple K</td> <td>-2700 to 13720 (-2000 to 12000)</td> </tr> <tr> <td>Thermocouple E</td> <td>-2700 to 10000 (-2000 to 9000)</td> </tr> <tr> <td>Thermocouple J</td> <td>-2100 to 12000 (-400 to 7500)</td> </tr> <tr> <td>Thermocouple T</td> <td>-2700 to 4000 (-2000 to 3500)</td> </tr> <tr> <td>Thermocouple B</td> <td>0 to 18200 (6000 to 17000)</td> </tr> <tr> <td>Thermocouple R</td> <td>-500 to 17680 (0 to 16000)</td> </tr> <tr> <td>Thermocouple S</td> <td>-500 to 17680 (0 to 16000)</td> </tr> <tr> <td>Thermocouple N</td> <td>-2700 to 13000 (-2000 to 12500)</td> </tr> <tr> <td>Micro voltage input</td> <td>-8000 to 8000 (-8000 to 8000)</td> </tr> </tbody> </table>	Input type	Setting range (Accuracy guarantee range)	Thermocouple K	-2700 to 13720 (-2000 to 12000)	Thermocouple E	-2700 to 10000 (-2000 to 9000)	Thermocouple J	-2100 to 12000 (-400 to 7500)	Thermocouple T	-2700 to 4000 (-2000 to 3500)	Thermocouple B	0 to 18200 (6000 to 17000)	Thermocouple R	-500 to 17680 (0 to 16000)	Thermocouple S	-500 to 17680 (0 to 16000)	Thermocouple N	-2700 to 13000 (-2000 to 12500)	Micro voltage input	-8000 to 8000 (-8000 to 8000)
Input type	Setting range (Accuracy guarantee range)																				
Thermocouple K	-2700 to 13720 (-2000 to 12000)																				
Thermocouple E	-2700 to 10000 (-2000 to 9000)																				
Thermocouple J	-2100 to 12000 (-400 to 7500)																				
Thermocouple T	-2700 to 4000 (-2000 to 3500)																				
Thermocouple B	0 to 18200 (6000 to 17000)																				
Thermocouple R	-500 to 17680 (0 to 16000)																				
Thermocouple S	-500 to 17680 (0 to 16000)																				
Thermocouple N	-2700 to 13000 (-2000 to 12500)																				
Micro voltage input	-8000 to 8000 (-8000 to 8000)																				

(2) Execution result in **Cr** Command result area

The execution result of the command changes depending on the result (normal completion or abnormal completion) in **Cr.0(15-8)** Command execution result.

(a) Normal completion (When **Cr.0(15-8)** Command execution result is 00H)

Cr Command result area	Result details		
Cr.0	<p>The command execution result is stored into the higher byte, and the start slice No. of execution target into the lower byte in hexadecimal as shown below.</p> <p>b15 to b8 b7 to b0</p> <table border="1" style="margin-left: 40px;"> <tr> <td style="width: 80px;">Cr.0(15-8) Command Execution Result</td> <td style="width: 80px;">Cr.0(7-0) Start Slice No. of Execution Target</td> </tr> </table> <p style="margin-left: 100px;">→ 00H: Normal completion</p>	Cr.0(15-8) Command Execution Result	Cr.0(7-0) Start Slice No. of Execution Target
Cr.0(15-8) Command Execution Result	Cr.0(7-0) Start Slice No. of Execution Target		
Cr.1	The executed command no. is stored. (Hexadecimal)		
Cr.2	0000H		
Cr.3			

(b) Abnormal completion (When **Cr.0(15-8)** Command execution result is other than 00H)

Cr Command result area	Result details		
Cr.0	<p>The command execution result is stored into the higher byte, and the start slice No. of execution target into the lower byte in hexadecimal as shown below.</p> <p>b15 to b8 b7 to b0</p> <table border="1" style="margin-left: 40px;"> <tr> <td style="width: 80px;">Cr.0(15-8) Command Execution Result</td> <td style="width: 80px;">Cr.0(7-0) Start Slice No. of Execution Target *1</td> </tr> </table> <p style="margin-left: 100px;">→ Other than 00H: Abnormal completion (see Section 8.6)</p> <p>*1: When 0FH is stored into the Cr.0(15-8) Command Execution Result, 00H (start slice No. of head module) is stored into the Cr.0(7-0) Start Slice No. of Execution Target.</p>	Cr.0(15-8) Command Execution Result	Cr.0(7-0) Start Slice No. of Execution Target *1
Cr.0(15-8) Command Execution Result	Cr.0(7-0) Start Slice No. of Execution Target *1		
Cr.1	The executed command no. is stored. (Hexadecimal)		
Cr.2	Cw.2 Argument 1 at command execution is stored.		
Cr.3	Cw.3 Argument 2 at command execution is stored.		

8.5.6 User range write (Command No.: 3305H)

Writes the adjusted offset/gain settings to the ROM of the ST1TD2.
This command can be executed only in the offset/gain setting mode.

(1) Values set to **Cw** Command execution area

Cw Command execution area	Setting value
Cw.0	Set the start slice number of the ST1TD2 where the command will be executed. (Hexadecimal)
Cw.1	3305H
Cw.2	Fixed to 0000H (Any value other than 0000H is ignored.)
Cw.3	

(2) Execution result in **Cr** Command result area

The execution result of the command changes depending on the result (normal completion or abnormal completion) in **Cr.0(15-8)** Command execution result.

(a) Normal completion (When **Cr.0(15-8)** Command execution result is 00H)

Cr Command result area	Result details		
Cr.0	<p>The command execution result is stored into the higher byte, and the start slice No. of execution target into the lower byte in hexadecimal as shown below.</p> <p>b15 to b8 b7 to b0</p> <table border="1" style="margin-left: 40px;"> <tr> <td style="width: 80px;">Cr.0(15-8) Command Execution Result</td> <td style="width: 80px;">Cr.0(7-0) Start Slice No. of Execution Target</td> </tr> </table> <p style="margin-left: 40px;">→ 00H: Normal completion</p>	Cr.0(15-8) Command Execution Result	Cr.0(7-0) Start Slice No. of Execution Target
Cr.0(15-8) Command Execution Result	Cr.0(7-0) Start Slice No. of Execution Target		
Cr.1	The executed command no. is stored. (Hexadecimal)		
Cr.2	0000H		
Cr.3			

(b) Abnormal completion (When **Cr.0(15-8)** Command execution result is other than 00H)

Cr Command result area	Result details		
Cr.0	<p>The command execution result is stored into the higher byte, and the start slice No. of execution target into the lower byte in hexadecimal as shown below.</p> <p>b15 to b8 b7 to b0</p> <table border="1" style="margin-left: 40px;"> <tr> <td style="width: 80px;">Cr.0(15-8) Command Execution Result</td> <td style="width: 80px;">Cr.0(7-0) Start Slice No. of Execution Target *1</td> </tr> </table> <p style="margin-left: 40px;">→ Other than 00H: Abnormal completion (see Section 8.6)</p> <p>*1: When 0FH is stored into the Cr.0(15-8) Command Execution Result, 00H (start slice No. of head module) is stored into the Cr.0(7-0) Start Slice No. of Execution Target.</p>	Cr.0(15-8) Command Execution Result	Cr.0(7-0) Start Slice No. of Execution Target *1
Cr.0(15-8) Command Execution Result	Cr.0(7-0) Start Slice No. of Execution Target *1		
Cr.1	The executed command no. is stored. (Hexadecimal)		
Cr.2	Cw.2 Argument 1 at command execution is stored.		
Cr.3	Cw.3 Argument 2 at command execution is stored.		

8.6 Values Stored into Command Execution Result

The following table indicates the values stored into **Cr.0(15-8)** Command execution result in **Cr** Command result area.

Cr.0 (15-8) Command execution result	Description	Corrective action
00H	Normal completion	—
01H	The requested command is not available for the specified module.	Check Table 8.1 to see if the requested command no. can be used with the ST1TD2 or not. Check whether the specified start slice No. of execution target is the start slice No. of the ST1TD2.
02H	The value set in Cw.2 Argument 1 or Cw.3 Argument 2 is outside the allowable range.	Check whether the value set to Cw.2 Argument 1 or Cw.3 Argument 2 in the command execution area is within the range usable for the requested command no.
03H	The start slice No. of the execution target is wrong.	Check whether the ST1TD2 is mounted to the specified start slice No. of execution target. Check whether the specified start slice No. of execution target is the start slice No. of the ST1TD2.
04H	There is no response from the specified module.	Check Table 8.1 to see if the requested command no. can be used with the ST1TD2 or not. When the requested command no. can be used, the possible cause is a ST1TD2 failure. Please consult your local distributor or branch office, explaining a description of the problem.
05H	No communication is available with the specified module.	The possible cause is a ST1TD2 failure. Please consult your local distributor or branch office, explaining a description of the problem.
06H	The requested command is not executable in the current operating status (operation mode) of the module.	Check Table 8.1 to see if the requested command number can be used with the ST1TD2 or not. User range write (command number: 3305H) or Parameter setting ROM write (command number: 3301H) was executed more than 25 times after power-on. (Error code: 1200H) Execute the command after clearing the error using Ew.n error clear request. When offset/gain setting was made, the offset value was greater than or equal to the gain value (Error code: 400□H). After clearing the error using Ew.n error clear request, make the offset/gain setting again so that the offset value is less than the gain value. When setting the offset/gain values, the gain value minus the offset value is less than or equal to 0.2°C, or less than or equal to 20μV. (Error Code: 410□H.) After clearing errors using Ew.n Error clear request, make the offset/gain setting again so that the gain value minus the offset value is more than 0.2°C, or more than 20μV.

Cr.0 (15-8) Command execution result	Description	Corrective action
07H	The module has already been in the specified mode.	Continue the processing since the operation mode of the ST1TD2 specified by the start slice No. of execution target is the mode already requested.
08H	The module cannot be changed into the specified mode.	Execute the command after turning $\overline{\text{Bw.n+1}}$ convert setting request to OFF (0).
09H	The specified module is in the online module change status.	Execute the command after online module change is completed.
10H	Data cannot be read from the specified module.	Execute the command again. If the problem on the left persists, the possible cause is a ST1TD2 failure.
11H	Data cannot be written to the specified module.	Please consult your local distributor or branch office, explaining a description of the problem.
13H	The specified module is not in the status available for parameter writing.	Execute the command after turning $\overline{\text{Bw.n+1}}$ convert setting request to OFF (0).
0FH	The value of $\overline{\text{Cw.0}}$ Start Slice No. of Execution Target is outside the applicable range.	Check whether the value set at $\overline{\text{Cw.0}}$ Start Slice No. of Execution Target is not more than 7FH.

9 TROUBLESHOOTING

This chapter explains the errors that may occur when the ST1TD2 is used, and how to troubleshoot them.

9.1 Error Code List

In the ST1TD2, when an error occurs due to write of data to the master module, executing error code read request (command no.: 0101H) stores the error code into Cr Command result area of the head module.

Table 9.1 Error code list (1/2)

Error code (Hexadecimal)	Error level	Error name	Description	Corrective action
1100H	System error	ROM error	ROM fault.	Power the ST1TD2 off and then on, or reset the head module. If the error code given on the left is still stored, the possible cause is a ST1TD2 failure. Please consult your local Mitsubishi representative, explaining a detailed description of the problem.
1200H	System error	Number of writes for ROM error	Parameter setting ROM write (command no.: 3301H) or User range write (command no.: 3305H) was executed more than 25 times after power-on. Offset/gain settings were written to the ROM using GX Configurator-ST more than 25 times after power-on.	After power-on, execute the command for a single module, or write offset/gain settings to the ROM using GX Configurator-ST, within 25 times.
1300H	System error	Converter error	A converter is faulty.	Turn the convert setting request off to clear the error. Then, turn the convert setting request on again.
1400H	System error	Base module error	Base module fault.	Power the ST1TD2 off and then on, or reset the head module. If the error code given on the left is still stored, the possible cause is a base module failure. Please consult your local Mitsubishi representative, explaining a detailed description of the problem.*
200□H	System error	Input type setting error	The value set to input type setting is outside the valid range. □ indicates the number of the channel where the error has occurred.	Set a value that is within the valid range.
210□H	System error	Average setting error	The average time setting is outside the range 480 to 5000ms. □ indicates the number of the channel where the error has occurred.	Set a value that is within the valid range.
220□H	System error	Average setting error	The average number of times setting is outside the range 4 to 500 times. □ indicates the number of the channel where the error has occurred.	Set a value that is within the valid range.

* If the error code: 1400H is stored after replacing the base module, the ST1TD2 may be faulty. Please consult your local Mitsubishi representative, explaining a detailed description of the problem.

Table 9.1 Error code list (2/2)

Error code (Hexadecimal)	Error level	Error name	Description	Corrective action																				
300□ _H	System error	Alarm setting error	<p>The value set to the upper upper limit value/upper lower limit value/lower upper limit value/lower lower limit value of the alarm output is outside the valid range.</p> <p>Setting range on each input type is shown below.</p> <table border="1"> <thead> <tr> <th>Input type</th> <th>Setting range (Accuracy guarantee range)</th> </tr> </thead> <tbody> <tr> <td>Thermocouple K</td> <td>-2700 to 13720 (-2000 to 12000)</td> </tr> <tr> <td>Thermocouple E</td> <td>-2700 to 10000 (-2000 to 9000)</td> </tr> <tr> <td>Thermocouple J</td> <td>-2100 to 12000 (-400 to 7500)</td> </tr> <tr> <td>Thermocouple T</td> <td>-2700 to 4000 (-2000 to 3500)</td> </tr> <tr> <td>Thermocouple B</td> <td>0 to 18200 (6000 to 17000)</td> </tr> <tr> <td>Thermocouple R</td> <td>-500 to 17680 (0 to 16000)</td> </tr> <tr> <td>Thermocouple S</td> <td>-500 to 17680 (0 to 16000)</td> </tr> <tr> <td>Thermocouple N</td> <td>-2700 to 13000 (-2000 to 12500)</td> </tr> <tr> <td>Micro voltage input</td> <td>-21000 to 21000 (-20000 to 20000)</td> </tr> </tbody> </table> <p>□ indicates the number of the channel where the error has occurred.</p>	Input type	Setting range (Accuracy guarantee range)	Thermocouple K	-2700 to 13720 (-2000 to 12000)	Thermocouple E	-2700 to 10000 (-2000 to 9000)	Thermocouple J	-2100 to 12000 (-400 to 7500)	Thermocouple T	-2700 to 4000 (-2000 to 3500)	Thermocouple B	0 to 18200 (6000 to 17000)	Thermocouple R	-500 to 17680 (0 to 16000)	Thermocouple S	-500 to 17680 (0 to 16000)	Thermocouple N	-2700 to 13000 (-2000 to 12500)	Micro voltage input	-21000 to 21000 (-20000 to 20000)	Set a value that is within the valid range.
Input type	Setting range (Accuracy guarantee range)																							
Thermocouple K	-2700 to 13720 (-2000 to 12000)																							
Thermocouple E	-2700 to 10000 (-2000 to 9000)																							
Thermocouple J	-2100 to 12000 (-400 to 7500)																							
Thermocouple T	-2700 to 4000 (-2000 to 3500)																							
Thermocouple B	0 to 18200 (6000 to 17000)																							
Thermocouple R	-500 to 17680 (0 to 16000)																							
Thermocouple S	-500 to 17680 (0 to 16000)																							
Thermocouple N	-2700 to 13000 (-2000 to 12500)																							
Micro voltage input	-21000 to 21000 (-20000 to 20000)																							
312□ _H	System error	Alarm setting error	<p>In the lower upper limit value/lower lower limit value of the alarm output, the lower upper limit value is less than the lower lower limit value.</p> <p>□ indicates the number of the channel where the error has occurred.</p>	Re-set the limit values so that the condition of upper upper limit value ≥ upper lower limit value ≥ lower upper limit value ≥ lower lower limit value is satisfied.																				
313□ _H	System error	Alarm setting error	<p>In the upper lower limit value/lower upper limit value of the alarm output, the upper lower limit value is less than the lower upper limit value.</p> <p>□ indicates the number of the channel where the error has occurred.</p>																					
314□ _H	System error	Alarm setting error	<p>In the upper upper limit value/upper lower limit value of the alarm output, the upper upper limit value is less than the upper lower limit value.</p> <p>□ indicates the number of the channel where the error has occurred.</p>																					
400□ _H	System error	User range setting error	<p>In User range setting, offset value is equal to or greater than gain value.</p> <p>□ indicates the number of the channel where the error has occurred.</p>	Reset the range so that offset value is smaller than gain value.																				
410□ _H	System error	User range setting error	<p>In user range setting, gain value - offset value ≤ 0.2 [°C] or gain value - offset value ≤ 20[μV]</p> <p>□ indicates the number of the channel where the error has occurred.</p>	Reset the user range to gain value - offset value > 0.2[°C] or gain value - offset value > 20[μV].																				
500□ _H	System error	Disconnection detection error	<p>Line break down has been detected.</p> <p>□ indicates the number of the channel where the error has occurred.</p>	Check for any abnormality on the signal lines by doing a visual check and performing a continuity check.																				

POINT

- (1) When multiple errors of the same level occur, the code of the error first found by the ST1TD2 is stored.
- (2) The error can be cleared by turning on **Ew.n** error clear request.

9.2 Troubleshooting

9.2.1 When the RUN LED is flashing or turned off

(1) When flashing at 0.5s intervals

Check item	Corrective action
Is the offset/gain setting mode active ?	Execute Operation mode setting (command number: 3302H) to activate the normal mode. (see Section 8.5.3).

(2) When flashing at 0.25s intervals

Check item	Corrective action
Is the module selected as the target of online module change?	Refer to Chapter 7 and take corrective action.

(3) When flashing at 1s intervals

Check item	Corrective action
Has data communication been stopped between the master station and head module?	Refer to the MELSEC-ST System User's Manual and take corrective action.
Has a parameter communication error occurred between the master station and head module?	
Has an error occurred in another slice module?	
Has an internal bus error occurred?	

(4) When off

Check item	Corrective action
Is a module change enabled during an online module change?	Refer to Chapter 7 and take corrective action.
Is External SYS. power supply being supplied?	Check whether the supply voltage of the bus refreshing module is within the rated range.
Is the capacity of the bus refreshing module adequate?	Calculate the current consumption of the mounted modules, and check that the power supply capacity is sufficient.
Is the ST1TD2 correctly mounted on the base module?	Check the mounting condition of the ST1TD2.
Has a watchdog timer error occurred?	Power the ST1TD2 off and then on, or reset the head module, and check whether the LED turns on. If the LED still does not turn on, the possible cause is a ST1TD2 failure. Please consult your local Mitsubishi representative, explaining a detailed description of the problem.

9.2.2 When the RUN LED and the ERR. LED turned on

Check item	Corrective action
Is an error being generated?	Confirm the error code and take corrective action described in Section 9.1.

9.2.3 When line break down has been detected

Check item	Corrective action
Check whether the thermocouple, compensation lead wire or micro voltage signal cable is connected incompletely or not.	Connect the thermocouple, compensation lead wire or micro voltage signal cable securely.
Is the terminal screw tightened enough when the base module is screw clamp type?	Retighten the terminal screws within the specified torque range. For the specified torque range of terminal screw, refer to the MELSEC-ST System User's Manual.
Check the connected thermocouple, compensation lead wire or micro voltage signal cable for wire break.	Make continuity check on the thermocouple, compensation lead wire or micro voltage signal cable, and replace it if it is broken.
Check whether the channel where no thermocouple or micro voltage signal cable is connected is set to conversion-enabled.	Check the channels which are set to conversion-enabled and the channels where thermocouples or micro voltage signal cables are connected, and make the correct conversion enable setting.

9.2.4 Measured temperature value/micro voltage conversion cannot be read

Check item	Corrective action
Is external AUX. power being supplied?	Check whether the power distribution modules is supplied with a 24V DC voltage.
Is there any fault with the analog signal lines such as broken or disconnected line?	Check for any abnormality on the signal lines by doing a visual check or continuity check.
Are the offset/gain settings correct?	Verify that the offset/gain settings are correct. (see section 4.5 and 5.6) When the user range setting is used, switch it to the factory default setting and check whether conversion is performed correctly or not. If it is correctly performed, redo the offset/gain setting.
Is the input type setting correct?	Execute user range set value read (command number: 1318H) and confirm the input type setting. (see section 8.3.7) If the input type setting is wrong, make the setting again using the configuration software of the master station.
Is the conversion enable/disable setting for the channel, where data was input, set to Disable?	Execute conversion enable/disable setting read (command number: 1300H) and confirm the conversion enable/disable setting. (see section 8.3.1) If conversion is disabled, enable conversion by executing conversion enable/disable setting write (command number: 2300H) or using GX Configurator-ST (see section 5.3 and 8.4.1).
Are $Bw.n+1$ convert setting request and $Br.n+1$ convert setting completed flag on?	Check whether $Bw.n+1$ convert setting request and $Br.n+1$ convert setting completed flag are on or off using the program of the master station or the I/O monitor of GX Configurator-ST (see section 5.4). If $Bw.n+1$ convert setting request and $Br.n+1$ convert setting completed flag are off, reexamine the program of the master station (see section 3.3.1 and 3.3.5).

9.2.5 Measured temperature value is abnormal

Check Item	Corrective action
Check whether the connected thermocouple or compensation lead wire differs from the setting.	Set the input type setting (User Parameter) to the connected thermocouple type.
Check whether the connected thermocouple or compensation lead wire is connected reversely.	Connect the thermocouple or compensation lead wire correctly.
Check for noise in the thermocouple input.	Check influence from the ground and adjacent devices, and take action to prevent noise.
Is the cold junction temperature compensation setting correct?	Set the cold junction temperature compensation setting (User Parameter) correctly.
Check whether conversion is made with the other thermocouple set after setting of the offset/gain value.	Make offset/gain setting again for the thermocouple changed.

9.2.6 Micro voltage conversion value is abnormal

Check Item	Corrective action
Check whether the input type set is a thermocouple or not.	Set the input type setting (User Parameter) to the micro voltage input.
Check the micro voltage signal cable for noise.	Check influence from grounding and adjacent equipment, and take noise reduction measures.
After offset/gain value setting, the other signal cable was connected.	Make offset/gain setting again with the newly connected signal cable.

POINT

If the normal measured temperature value/measured micro voltage value cannot be read after taking corrective actions corresponding to the above check items, the possible cause is a module failure. Please consult your local Mitsubishi representative, explaining a detailed description of the problem.

APPENDIX

Appendix 1 Accessories

This section explains the accessories related to the ST1TD2.

(1) Wiring maker



For how to use the wiring marker, refer to the MELSEC-ST System User's Manual.

Model name	Description	Color
ST1A-WMK-BL	Terminal marker (-, 0V, N)	Blue
ST1A-WMK-BK	Terminal marker (Signal wire)	Black



(2) Coding element

The coding element is fitted before shipment.

It is also available as an option in case it is lost.

Model name	Description	Shape*		Color
		Base module side	Slice module side	
ST1A-CKY-16	Coding element for ST1TD2			Dusty gray

* Indicates the position of the projection or hole when the coding element is viewed from above.

: Projection : Hole

Appendix 2 Usual Operation Limit and Superheated Operation Limits

Conform to JIS C1602-1995

Component symbol	Old symbol (reference)	Wire diameter mm	Usual operation °C	Superheated operating limit °C
K	CA	0.65	650	850
		1.00	750	950
		1.60	850	1050
		2.30	900	1100
		3.20	1000	1200
E	CRC	0.65	450	500
		1.00	500	550
		1.60	550	600
		2.30	600	750
		3.20	700	800
J	IC	0.65	400	500
		1.00	450	550
		1.60	500	650
		2.30	550	750
		3.20	600	750
T	CC	0.32	200	250
		0.65	200	250
		1.00	250	300
		1.60	300	350
B	-	0.50	1500	1700
R	-	0.50	1400	1600
S				
N	-	0.65	850	900
		1.00	950	1000
		1.60	1050	1100
		2.30	1100	1150
		3.20	1200	1250

Note : The usual operation limit refers to the temperature limit of the air in which the module can be continuously used.

The superheated operating limit refers to the limit of temperature at which the module can be used in a short period of the time unavoidable cases.

Appendix 3 Allowable Temperature Differences

Conform to IEC584-2, JIS C1602-1995

Component symbol	Measured temperature	Class	Allowable difference
K	- 40°C or more but less than 375°C	Class 1	±1.5°C
	375°C or more but less than 1000°C		±0.4% of the measured temperature
	- 40°C or more but less than 333°C	Class 2	±2.5°C
	333°C or more but less than 1200°C		±0.75% of the measured temperature
	- 200°C or more but less than -167°C	Class 3	±1.5% of the measured temperature
	- 167°C or more but less than 40°C		±2.5°C
E	- 40°C or more but less than 375°C	Class 1	±1.5°C
	375°C or more but less than 800°C		±0.4% of the measured temperature
	- 40°C or more but less than 333°C	Class 2	±2.5°C
	333°C or more but less than 900°C		±0.75% of the measured temperature
	- 200°C or more but less than -167°C	Class 3	±1.5% of the measured temperature
	- 167°C or more but less than 40°C		±2.5°C
J	- 40°C or more but less than 375°C	Class 1	±1.5°C
	375°C or more but less than 750°C		±0.4% of the measured temperature
	- 40°C or more but less than 333°C	Class 2	±2.5°C
	333°C or more but less than 750°C		±0.75% of the measured temperature
T	- 40°C or more but less than 125°C	Class 1	±0.5°C
	125°C or more but less than 350°C		±0.4% of the measured temperature
	- 40°C or more but less than 133°C	Class 2	±1°C
	133°C or more but less than 350°C		±0.75% of the measured temperature
	- 200°C or more but less than -67°C	Class 3	±1.5% of the measured temperature
	- 67°C or more but less than 40°C		±1°C
B	600°C or more but less than 1700°C	Class 2	±0.25% of the measured temperature
	600°C or more but less than 800°C	Class 3	±4°C
	800°C or more but less than 1700°C		±0.5% of the measured temperature
R	0°C or more but less than 1100°C	Class 1	±1°C
	0°C or more but less than 600°C	Class 2	±1.5°C
	600°C or more but less than 1600°C		±0.25% of the measured temperature
S	0°C or more but less than 1100°C	Class 1	±1°C
	0°C or more but less than 600°C	Class 2	±1.5°C
	600°C or more but less than 1600°C		±0.2% of the measured temperature
N	- 40°C or more but less than 375°C	Class 1	±1.5°C
	375°C or more but less than 1000°C		±0.4% of the measured temperature
	- 40°C or more but less than 333°C	Class 2	±2.5°C
	333°C or more but less than 1200°C		±0.75% of the measured temperature
	- 200°C or more but less than -167°C	Class 3	±1.5% of the measured temperature
	- 167°C or more but less than 40°C		±2.5°C

Note : The allowable difference refers to the maximum allowable limit for the difference between the resultant temperature of a conversion from thermal electromotive force using a standard thermal electromotive force chart, and the temperature at temperature detector contact.
The greater value of °C or % will take effect for the allowable difference.

Appendix 4 Thermal Electromotive Force Chart

The calculation formula for accuracy differs according to the relation between the measured temperature and the operating ambient temperature.

(1) When the measured temperature is higher than the operating ambient temperature

(Accuracy) = (conversion accuracy) + (temperature characteristic) × (operating ambient temperature variation) + (cold junction temperature compensation accuracy)

Operating ambient temperature variation: A value of deviation from the operating ambient temperature range of $25\pm 5^{\circ}\text{C}$

Example: When the thermocouple used is B (Refer to Section 3.1 (2)), the operating ambient temperature is 35°C , the measured temperature is 1000°C , and the cold junction temperature compensation setting is set, the accuracy is:

$$(\pm 3.5^{\circ}\text{C}) + (\pm 0.35^{\circ}\text{C}) \times (35^{\circ}\text{C} - 30^{\circ}\text{C}) + (\pm 2.5^{\circ}\text{C}) = \pm 7.75^{\circ}\text{C}$$

(2) When the measured temperature is lower than the operating ambient temperature

(Accuracy) = (conversion accuracy) + (temperature characteristic) × (operating ambient temperature variation) + (cold junction temperature compensation accuracy) × (compensation value for cold junction compensation accuracy)

Operating ambient temperature variation: A value of deviation from the operating ambient temperature range of $25\pm 5^{\circ}\text{C}$

When the measured temperature is lower than the operating ambient temperature, the cold junction compensation accuracy is lowered because the thermocouple's thermal electromotive force does not have a linear characteristic. Based on the thermal electromotive force table, compensate for the cold junction compensation accuracy.

Example) In the case of the thermocouple E (Refer to Section 3.1 (2)), operating ambient temperature of 25°C , measured temperature of -100°C and the cold junction temperature compensation yes setting,
 Type E thermal electromotive force at around 25°C : $61\mu\text{V}/^{\circ}\text{C}$
 Type E thermal electromotive force at around -100°C : $45\mu\text{V}/^{\circ}\text{C}$
 The compensation value for cold junction compensation accuracy is:
 $[61\mu\text{V}/^{\circ}\text{C}]/[45\mu\text{V}/^{\circ}\text{C}] = 1.4$

And the accuracy is:

$$(\pm 1.5^{\circ}\text{C}) + (\pm 1.5^{\circ}\text{C}) \times 1.4 = \pm 3.6^{\circ}\text{C}$$

Appendix 4.1 Standard Thermal Electromotive Force of K

Type K

Conform to IEC584-1(1977), IEC584-2(1982), JIS C1602-1995

Unit μV

Temperature (°C)	0	-1	-2	-3	-4	-5	-6	-7	-8	-9	Temperature (°C)
-270	-6458										-270
-260	-6441	-6444	-6446	-6448	-6450	-6452	-6453	-6455	-645-6	-6457	-260
-250	-6404	-6408	-6413	-6417	-6421	-6425	-6429	-6432	-6435	-6438	-250
-240	-6344	-6351	-6358	-6364	-6370	-6377	-6382	-6388	-6393	-6399	-240
-230	-6262	-6271	-6280	-6289	-6297	-6306	-6314	-6322	-6329	-6337	-230
-220	-6158	-6170	-6181	-6192	-6202	-6213	-6223	-6233	-6243	-6252	-220
-210	-6035	-6048	-6061	-6074	-6087	-6099	-6111	-6123	-6135	-6147	-210
-200	-5891	-5907	-5922	-5936	-5951	-5965	-5980	-5994	-6007	-6021	-200
-190	-5730	-5747	-5763	-5780	-5797	-5813	-5829	-5845	-5861	-5876	-190
-180	-5550	-5569	-5588	-5606	-5624	-5642	-5660	-5678	-5695	-5713	-180
-170	-5354	-5374	-5395	-5415	-5435	-5454	-5474	-5493	-5512	-5531	-170
-160	-5141	-5163	-5185	-5207	-5228	-5250	-5271	-5292	-5313	-5333	-160
-150	-4913	-4936	-4960	-4983	-5006	-5029	-5052	-5074	-5097	-5119	-150
-140	-4669	-4694	-4719	-4744	-4768	-4793	-4817	-4841	-4865	-4889	-140
-130	-4411	-4437	-4463	-4490	-4516	-4542	-4567	-4593	-4618	-4644	-130
-120	-4138	-4166	-4194	-4221	-4249	-4276	-4303	-4330	-4357	-4384	-120
-110	-3852	-3882	-3911	-3939	-3968	-3997	-4025	-4054	-4082	-4110	-110
-100	-3554	-3584	-3614	-3645	-3675	-3705	-3734	-3764	-3794	-3823	-100
-90	-3243	-3274	-3306	-3337	-3368	-3400	-3431	-3462	-3492	-3523	-90
-80	-2920	-2953	-2986	-3018	-3050	-3083	-3115	-3147	-3179	-3211	-80
-70	-2587	-2620	-2654	-2688	-2721	-2755	-2788	-2821	-2854	-2887	-70
-60	-2243	-2278	-2312	-2347	-2382	-2416	-2450	-2485	-2519	-2553	-60
-50	-1889	-1925	-1961	-1996	-2032	-2067	-2103	-2138	-2173	-2208	-50
-40	-1527	-1564	-1600	-1637	-1673	-1709	-1745	-1782	-1818	-1854	-40
-30	-1156	-1194	-1231	-1268	-1305	-1343	-1380	-1417	-1453	-1490	-30
-20	-778	-816	-854	-892	-930	-968	-1006	-1043	-1081	-1119	-20
-10	-392	-431	-470	-508	-547	-586	-624	-663	-701	-739	-10
0	0	-39	-79	-118	-157	-197	-236	-275	-314	-353	0
Temperature (°C)	0	1	2	3	4	5	6	7	8	9	Temperature (°C)
0	0	39	79	119	158	198	238	277	317	357	0
10	397	437	477	517	557	597	637	677	718	758	10
20	798	838	879	919	960	1000	1041	1081	1122	1163	20
30	1203	1244	1285	1326	1366	1407	1448	1489	1530	1571	30
40	1612	1653	1694	1735	1776	1817	1858	1899	1941	1982	40
50	2023	2064	2106	2147	2188	2230	2271	2312	2354	2395	50
60	2436	2478	2519	2561	2602	2644	2685	2727	2768	2810	60
70	2851	2893	2934	2976	3017	3059	3100	3142	3184	3225	70
80	3267	3308	3350	3391	3433	3474	3516	3557	3599	3640	80
90	3682	3723	3765	3806	3848	3889	3931	3972	4013	4055	90
100	4096	4138	4179	4220	4262	4303	4344	4385	4427	4468	100
110	4509	4550	4591	4633	4674	4715	4756	4797	4838	4879	110
120	4920	4961	5002	5043	5084	5124	5165	5206	5247	5288	120
130	5328	5369	5410	5450	5491	5532	5572	5613	5653	5694	130
140	5735	5775	5815	5856	5896	5937	5977	6017	6058	6098	140
										357	

Type K

 Unit μ V

Conform to IEC584-1(1977), IEC584-2(1982), JIS C1602-1995

Temperature (°C)	0	1	2	3	4	5	6	7	8	9	Temperature (°C)
150	6138	6179	6219	6259	6299	6339	6380	6420	6460	6500	150
160	6540	6580	6620	6660	6701	6741	6781	6821	6861	6901	160
170	6941	6981	7021	7060	7100	7140	7180	7220	7260	7300	170
180	7340	7380	7420	7460	7500	7540	7579	7619	7659	7699	180
190	7739	7779	7819	7859	7899	7939	7979	8019	8059	8099	190
200	8138	8178	8218	8258	8298	8338	8378	8418	8458	8499	200
210	8539	8579	8619	8659	8699	8739	8779	8819	8860	8900	210
220	8940	8980	9020	9061	9101	9141	9181	9222	9262	9302	220
230	9343	9383	9423	9464	9504	9545	9585	9626	9666	9707	230
240	9747	9788	9828	9869	9909	9950	9991	10031	10072	10113	240
250	10153	10194	10235	10276	10316	10357	10398	10439	10480	10520	250
260	10561	10602	10643	10684	10725	10766	10807	10848	10889	10930	260
270	10971	11012	11053	11094	11135	11176	11217	11259	11300	11341	270
280	11382	11423	11465	11506	11547	11588	11630	11671	11712	11753	280
290	11795	11836	11877	11919	11960	12001	12043	12084	12126	12167	290
300	12209	12250	12291	12333	12374	12416	12457	12499	12540	12582	300
310	12624	12665	12707	12748	12790	12831	12873	12915	12956	12998	310
320	13040	13081	13123	13165	13206	13248	13290	13331	13373	13415	320
330	13457	13498	13540	13582	13624	13665	13707	13749	13791	13833	330
340	13874	13916	13958	14000	14042	14084	14126	14167	14209	14251	340
350	14293	14335	14377	14419	14461	14503	14545	14587	14629	14671	350
360	14713	14755	14797	14839	14881	14923	14965	15007	15049	15091	360
370	15133	15175	15217	15259	15301	15343	15385	15427	15469	15511	370
380	15554	15596	15638	15680	15722	15764	15806	15849	15891	15933	380
390	15975	16017	16059	16102	16144	16186	16228	16270	16313	16355	390
400	16397	16439	16482	16524	16566	16608	16651	16693	16735	16778	400
410	16820	16862	16904	16947	16989	17031	17074	17116	17158	17201	410
420	17243	17285	17328	17370	17413	17455	17497	17540	17582	17624	420
430	17667	17709	17752	17794	17837	17879	17921	17964	18006	18049	430
440	18091	18134	18176	18218	18261	18303	18346	18388	18431	18473	440
450	18516	18558	18601	18643	18686	18728	18771	18813	18856	18898	450
460	18941	18983	19026	19068	19111	19154	19196	19239	19281	19324	460
470	19366	19409	19451	19494	19537	19579	19622	19664	19707	19750	470
480	19792	19835	19877	19920	19962	20005	20048	20090	20133	20175	480
490	20218	20261	20303	20346	20389	20431	20474	20516	20559	20602	490
500	20644	20687	20730	20772	20815	20857	20900	20943	20985	21028	500
510	21071	21113	21156	21199	21241	21284	21326	21369	21412	21454	510
520	21497	21540	21582	21625	21668	21710	21753	21796	21838	21881	520
530	21924	21966	22009	22052	22094	22137	22179	22222	22265	22307	530
540	22350	22393	22435	22478	22521	22563	22606	22649	22691	22734	540
550	22776	22819	22862	22904	22947	22990	23032	23075	23117	23160	550
560	23203	23245	23288	23331	23373	23416	23458	23501	23544	23586	560
570	23629	23671	23714	23757	23799	23842	23884	23927	23970	24012	570
580	24055	24097	24140	24182	24225	24267	24310	24353	24395	24438	580
590	24480	24523	24565	24608	24650	24693	24735	24778	24820	24863	590

Type K

 Unit μ V

Conform to IEC584-1(1977), IEC584-2(1982), JIS C1602-1995

Temperature (°C)	0	1	2	3	4	5	6	7	8	9	Temperature (°C)
600	24905	24948	24990	25033	25075	25118	25160	25203	25245	25288	600
610	25330	25373	25415	25458	25500	25543	25585	25627	25670	25712	610
620	25755	25797	25840	25882	25924	25967	26009	26052	26094	26136	620
630	26179	26221	26263	26306	26348	26390	26433	26475	26517	26560	630
640	26602	26644	26687	26729	26771	26814	26856	26898	26940	26983	640
650	27025	27067	27109	27152	27194	27236	27278	27320	27363	27405	650
660	27447	27489	27531	27574	27616	27658	27700	27742	27784	27826	660
670	27869	27911	27953	27995	28037	28079	28121	28163	28205	28247	670
680	28289	28332	28374	28416	28458	28500	28542	28584	28626	28668	680
690	28710	28752	28794	28835	28877	28919	28961	29003	29045	29087	690
700	29129	29171	29213	29255	29297	29338	29380	29422	29464	29506	700
710	29548	29589	29631	29673	29715	29757	29798	29840	29882	29924	710
720	29965	30007	30049	30090	30132	30174	30216	30257	30299	30341	720
730	30382	30424	30466	30507	30549	30590	30632	30674	30715	30757	730
740	30798	30840	30881	30923	30964	31006	31047	31089	31130	31172	740
750	31213	31255	31296	31338	31379	31421	31462	31504	31545	31586	750
760	31628	31669	31710	31752	31793	31834	31876	31917	31958	32000	760
770	32041	32082	32124	32165	32206	32247	32289	32330	32371	32412	770
780	32453	32495	32536	32577	32618	32659	32700	32742	32783	32824	780
790	32865	32906	32947	32988	33029	33070	33111	33152	33193	33234	790
800	33275	33316	33357	33398	33439	33480	33521	33562	33603	33644	800
810	33685	33726	33767	33808	33848	33889	33930	33971	34012	34053	810
820	34093	34134	34175	34216	34257	34297	34338	34379	34420	34460	820
830	34501	34542	34582	34623	34664	34704	34745	34786	34826	34867	830
840	34908	34948	34989	35029	35070	35110	35151	35192	35232	35273	840
850	35313	35354	35394	35435	35475	35516	35556	35596	35637	35677	850
860	35718	35758	35798	35839	35879	35920	35960	36000	36041	36081	860
870	36121	36162	36202	36242	36282	36323	36363	36403	36443	36484	870
880	36524	36564	36604	36644	36685	36725	36765	36805	36845	36885	880
890	36925	36965	37006	37046	37086	37126	37166	37206	37246	37286	890
900	37326	37366	37406	37446	37486	37526	37566	37606	37646	37686	900
910	37725	37765	37805	37845	37885	37925	37965	38005	38044	38084	910
920	38124	38164	38204	38243	38283	38323	38363	38402	38442	38482	920
930	38522	38561	38601	38641	38680	38720	38760	38799	38839	38878	930
940	38918	38958	38997	39037	39076	39116	39155	39195	39235	39274	940
950	39314	39353	39393	39432	39471	39511	39550	39590	39629	39669	950
960	39708	39747	39787	39826	39866	39905	39944	39984	40023	40062	960
970	40101	40141	40180	40219	40259	40298	40337	40376	40415	40455	970
980	40494	40533	40572	40611	40651	40690	40729	40768	40807	40846	980
990	40885	40924	40963	41002	41042	41081	41120	41159	41198	41237	990
1000	41276	41315	41354	41393	41431	41470	41509	41548	41587	41626	1000
1010	41665	41704	41743	41781	41820	41859	41898	41937	41976	42014	1010
1020	42053	42092	42131	42169	42208	42247	42286	42324	42363	42402	1020
1030	42440	42479	42518	42556	42595	42633	42672	42711	42749	42788	1030
1040	42826	42865	42903	42942	42980	43019	43057	43096	43134	43173	1040

Type K

Conform to IEC584-1(1977), IEC584-2(1982), JIS C1602-1995

Unit μV

Temperature (°C)	0	1	2	3	4	5	6	7	8	9	Temperature (°C)
1050	43211	43250	43288	43327	43365	43403	43442	43480	43518	43557	1050
1060	43595	43633	43672	43710	43748	43787	43825	43863	43901	43940	1060
1070	43978	44016	44054	44092	44130	44169	44207	44245	44283	44321	1070
1080	44359	44397	44435	44473	44512	44550	44588	44626	44664	44702	1080
1090	44740	44778	44816	44853	44891	44929	44967	45005	45043	45081	1090
1100	45119	45157	45194	45232	45270	45308	45346	45383	45421	45459	1100
1110	45497	45534	45572	45610	45647	45685	45723	45760	45798	45836	1110
1120	45873	45911	45948	45986	46024	46061	46099	46136	46174	46211	1120
1130	46249	46286	46324	46361	46398	46436	46473	46511	46548	46585	1130
1140	46623	46660	46697	46735	46772	46809	46847	46884	46921	46958	1140
1150	46995	47033	47070	47107	47144	47181	47218	47256	47293	47330	1150
1160	47367	47404	47441	47478	47515	47552	47589	47626	47663	47700	1160
1170	47737	47774	47811	47848	47884	47921	47958	47995	48032	48069	1170
1180	48105	48142	48179	48216	48252	48289	48326	48363	48399	48436	1180
1190	48473	48509	48546	48582	48619	48656	48692	48729	48765	48802	1190
1200	48838	48875	48911	48948	48984	49021	49057	49093	49130	49166	1200
1210	49202	49239	49275	49311	49348	49384	49420	49456	49493	49529	1210
1220	49565	49601	49637	49674	49710	49746	49782	49818	49854	49890	1220
1230	49926	49962	49998	50034	50070	50106	50142	50178	50214	50250	1230
1240	50286	50322	50358	50393	50429	50465	50501	50537	50572	50608	1240
1250	50644	50680	50715	50751	50787	50822	50858	50894	50929	50965	1250
1260	51000	51036	51071	51107	51142	51178	51213	51249	51284	51320	1260
1270	51355	51391	51426	51461	51497	51532	51567	51603	51638	51673	1270
1280	51708	51744	51779	51814	51849	51885	51920	51955	51990	52025	1280
1290	52060	52095	52130	52165	52200	52235	52270	52305	52340	52375	1290
1300	52410	52445	52480	52515	52550	52585	52620	52654	52689	52724	1300
1310	52759	52794	52828	52863	52898	52932	52967	53002	53037	53071	1310
1320	53106	53140	53175	53210	53244	53279	53313	53348	53382	53417	1320
1330	53451	53486	53520	53555	53589	53623	53658	53692	53727	53761	1330
1340	53795	53830	53864	53898	53932	53967	54001	54035	54069	54104	1340
1350	54138	54172	54206	54240	54274	54308	54343	54377	54411	54445	1350
1360	54479	54513	54547	54581	54615	54649	54683	54717	54751	54785	1360
1370	54819	54852	54886								1370

REMARK

Standard contact temperature is 0°C.

Appendix 4.2 Standard Thermal Electromotive Force of E

Type E

Conform to IEC584-1(1977), IEC584-2(1982), JIS C1602-1995

Unit μV

Temperature (°C)	0	-1	-2	-3	-4	-5	-6	-7	-8	-9	Temperature (°C)
-270	-9835										-270
-260	-9797	-9802	-9808	-9813	-9817	-9821	-9825	-9828	-9831	-9833	-260
-250	-9718	-9728	-9737	-9746	-9754	-9762	-9770	-9777	-9784	-9790	-250
-240	-9604	-9617	-9630	-9642	-9654	-9666	-9677	-9688	-9698	-9709	-240
-230	-9455	-9471	-9487	-9503	-9519	-9534	-9548	-9563	-9577	-9591	-230
-220	-9274	-9293	-9313	-9331	-9350	-9368	-9386	-9404	-9421	-9438	-220
-210	-9063	-9085	-9107	-9129	-9151	-9172	-9193	-9214	-9234	-9254	-210
-200	-8825	-8850	-8874	-8899	-8923	-8947	-8971	-8994	-9017	-9040	-200
-190	-8561	-8588	-8616	-8643	-8669	-8696	-8722	-8748	-8774	-8799	-190
-180	-8273	-8303	-8333	-8362	-8391	-8420	-8449	-8477	-8505	-8533	-180
-170	-7963	-7995	-8027	-8059	-8090	-8121	-8152	-8183	-8213	-8243	-170
-160	-7632	-7666	-7700	-7733	-7767	-7800	-7833	-7866	-7899	-7931	-160
-150	-7279	-7315	-7351	-7387	-7423	-7458	-7493	-7528	-7563	-7597	-150
-140	-6907	-6945	-6983	-7021	-7058	-7096	-7133	-7170	-7206	-7243	-140
-130	-6516	-6556	-6596	-6636	-6675	-6714	-6753	-6792	-6831	-6869	-130
-120	-6107	-6149	-6191	-6232	-6273	-6314	-6355	-6396	-6436	-6476	-120
-110	-5681	-5724	-5767	-5810	-5853	-5896	-5939	-5981	-6023	-6065	-110
-100	-5237	-5282	-5327	-5372	-5417	-5461	-5505	-5549	-5593	-5637	-100
-90	-4777	-4824	-4871	-4917	-4963	-5009	-5055	-5101	-5147	-5192	-90
-80	-4302	-4350	-4398	-4446	-4494	-4542	-4589	-4636	-4684	-4731	-80
-70	-3811	-3861	-3911	-3960	-4009	-4058	-4107	-4156	-4205	-4254	-70
-60	-3306	-3357	-3408	-3459	-3510	-3561	-3611	-3661	-3711	-3761	-60
-50	-2787	-2840	-2892	-2944	-2996	-3048	-3100	-3152	-3204	-3255	-50
-40	-2255	-2309	-2362	-2416	-2469	-2523	-2576	-2629	-2682	-2735	-40
-30	-1709	-1765	-1820	-1874	-1929	-1984	-2038	-2093	-2147	-2201	-30
-20	-1152	-1208	-1264	-1320	-1376	-1432	-1488	-1543	-1599	-1654	-20
-10	-582	-639	-697	-754	-811	-868	-925	-982	-1039	-1095	-10
0	0	-59	-117	-176	-234	-292	-350	-408	-466	-524	0
Temperature (°C)	0	1	2	3	4	5	6	7	8	9	Temperature (°C)
0	0	59	118	176	235	294	354	413	472	532	0
10	591	651	711	770	830	890	950	1010	1071	1131	10
20	1192	1252	1313	1373	1434	1495	1556	1617	1678	1740	20
30	1801	1862	1924	1986	2047	2109	2171	2233	2295	2357	30
40	2420	2482	2545	2607	2670	2733	2795	2858	2921	2984	40
50	3048	3111	3174	3238	3301	3365	3429	3492	3556	3620	50
60	3685	3749	3813	3877	3942	4006	4071	4136	4200	4265	60
70	4330	4395	4460	4526	4591	4656	4722	4788	4853	4919	70
80	4985	5051	5117	5183	5249	5315	5382	5448	5514	5581	80
90	5648	5714	5781	5848	5915	5982	6049	6117	6184	6251	90
100	6319	6386	6454	6522	6590	6658	6725	6794	6862	6930	100
110	6998	7066	7135	7203	7272	7341	7409	7478	7547	7616	110
120	7685	7754	7823	7892	7962	8031	8101	8170	8240	8309	120
130	8379	8449	8519	8589	8659	8729	8799	8869	8940	9010	130
140	9081	9151	9222	9292	9363	9434	9505	9576	9647	9718	140
150	9789	9860	9931	10003	10074	10145	10217	10288	10360	10432	150
160	10503	10575	10647	10719	10791	10863	10935	11007	11080	11152	160
170	11224	11297	11369	11442	11514	11587	11660	11733	11805	11878	170
180	11951	12024	12097	12170	12243	12317	12390	12463	12537	12610	180
190	12684	12757	12831	12904	12978	13052	13126	13199	13273	13347	190

Type E

Conform to IEC584-1(1977), IEC584-2(1982), JIS C1602-1995

Unit μ V

Temperature (°C)	0	1	2	3	4	5	6	7	8	9	Temperature (°C)
200	13421	13495	13569	13644	13718	13792	13866	13941	14015	14090	200
210	14164	14239	14313	14388	14463	14537	14612	14687	14762	14837	210
220	14912	14987	15062	15137	15212	15287	15362	15438	15513	15588	220
230	15664	15739	15815	15890	15966	16041	16117	16193	16269	16344	230
240	16420	16496	16572	16648	16724	16800	16876	16952	17028	17104	240
250	17181	17257	17333	17409	17486	17562	17639	17715	17792	17868	250
260	17945	18021	18098	18175	18252	18328	18405	18482	18559	18636	260
270	18713	18790	18867	18944	19021	19098	19175	19252	19330	19407	270
280	19484	19561	19639	19716	19791	19871	19948	20026	20103	20181	280
290	20259	20336	20414	20492	20569	20647	20725	20803	20880	20958	290
300	21036	21114	21192	21270	21348	21426	21504	21582	21660	21739	300
310	21817	21895	21973	22051	22130	22208	22286	22365	22443	22522	310
320	22600	22678	22757	22835	22914	22993	23071	23150	23228	23307	320
330	23386	23464	23543	23622	23701	23780	23858	23937	24016	24095	330
340	24174	24253	24332	24411	24490	24569	24648	24727	24806	24885	340
350	24964	25044	25123	25202	25281	25360	25440	25519	25598	25678	350
360	25757	25836	25916	25995	26075	26154	26233	26313	26392	26472	360
370	26552	26631	26711	26790	26870	26950	27029	27109	27189	27268	370
380	27348	27428	27507	27587	27667	27747	27827	27907	27986	28066	380
390	28146	28226	28306	28386	28466	28546	28626	28706	28786	28866	390
400	28946	29026	29106	29186	29266	29346	29427	29507	29587	29667	400
410	29747	29827	29908	29988	30068	30148	30229	30309	30389	30470	410
420	30550	30630	30711	30791	30871	30952	31032	31112	31193	31273	420
430	31354	31434	31515	31595	31676	31756	31837	31917	31998	32078	430
440	32159	32239	32320	32400	32481	32562	32642	32723	32803	32884	440
450	32965	33045	33126	33207	33287	33368	33449	33529	33610	33691	450
460	33772	33852	33933	34014	34095	34175	34256	34337	34418	34498	460
470	34579	34660	34741	34822	34902	34983	35064	35145	35226	35307	470
480	35387	35468	35549	35630	35711	35792	35873	35954	36034	36115	480
490	36196	36277	36358	36439	36520	36601	36682	36763	36843	36924	490
500	37005	37086	37167	37248	37329	37410	37491	37572	37653	37734	500
510	37815	37896	37977	38058	38139	38220	38300	38381	38462	38543	510
520	38624	38705	38786	38867	38948	39029	39110	39191	39272	39353	520
530	39434	39515	39596	39677	39758	39839	39920	40001	40082	40163	530
540	40243	40324	40405	40486	40567	40648	40729	40810	40891	40972	540
550	41053	41134	41215	41296	41377	41457	41538	41619	41700	41781	550
560	41862	41943	42024	42105	42185	42266	42347	42428	42509	42590	560
570	42671	42751	42832	42913	42994	43075	43156	43236	43317	43398	570
580	43479	43560	43640	43721	43802	43883	43963	44044	44125	44206	580
590	44285	44367	44448	44529	44609	44690	44771	44851	44932	45013	590
600	45093	45174	45255	45335	45416	45497	45577	45658	45738	45819	600
610	45900	45980	46061	46141	46222	46302	46383	46463	46544	46624	610
620	46705	46785	46866	46946	47027	47107	47188	47268	47349	47429	620
630	47509	47590	47670	47751	47831	47911	47992	48072	48152	48233	630
640	48313	48393	48474	48554	48634	48715	48795	48875	48955	49035	640
650	49116	49196	49276	49356	49436	49517	49597	49677	49757	49837	650
660	49917	49997	50077	50157	50238	50318	50398	50478	50558	50638	660
670	50718	50798	50878	50958	51038	51118	51197	51277	51357	51437	670
680	51517	51597	51677	51757	51837	51916	51996	52076	52156	52236	680
690	52315	52395	52475	52555	52634	52714	52794	52873	52953	53033	690

Type E

Conform to IEC584-1(1977), IEC584-2(1982), JIS C1602-1995

Unit μV

Temperature (°C)	0	1	2	3	4	5	6	7	8	9	Temperature (°C)
700	53112	53192	53272	53351	53431	53510	53590	53670	53749	53829	700
710	53908	53988	54067	54147	54226	54306	54385	54465	54544	54624	710
720	54703	54782	54862	54941	55021	55100	55179	55259	55338	55417	720
730	55497	55576	55655	55734	55814	55893	55972	56051	56131	56210	730
740	56289	56368	56447	56526	56606	56685	56764	56843	56922	57001	740
750	57080	57159	57238	57317	57396	57475	57554	57633	57712	57791	750
760	57870	57949	58028	58107	58186	58265	58343	58422	58501	58580	760
770	58659	58738	58816	58895	58974	59053	59131	59210	59289	59367	770
780	59446	59525	59604	59682	59761	59839	59918	59997	60075	60154	780
790	60232	60311	60390	60468	60547	60625	60704	60782	60860	60939	790
800	61017	61096	61174	61253	61331	61409	61488	61566	61644	61723	800
810	61801	61879	61958	62036	62114	62192	62271	62349	62427	62505	810
820	62583	62662	62740	62818	62896	62974	63052	63130	63208	63286	820
830	63364	63442	63520	63598	63676	63754	63832	63910	63988	64066	830
840	64144	64222	64300	64377	64455	64533	64611	64689	64766	64844	840
850	64922	65000	65077	65155	65233	65310	65388	65465	65543	65621	850
860	65698	65776	65853	65931	66008	66086	66163	66241	66318	66396	860
870	66473	66550	66628	66705	66782	66860	66937	67014	67092	67169	870
880	67246	67323	67400	67478	67555	67632	67709	67786	67863	67940	880
890	68017	68094	68174	68248	68325	68402	68479	68556	68633	68710	890
900	68787	68863	68940	69017	69094	69171	69247	69324	69401	69477	900
910	69554	69631	69707	69784	69860	69937	70013	70090	70166	70243	910
920	70319	70396	70472	70548	70625	70701	70777	70854	70930	71006	920
930	71082	71159	71235	71311	71387	71463	71539	71615	71692	71768	930
940	71844	71920	71996	72072	72147	72223	72299	72375	72451	72527	940
950	72603	72678	72754	72830	72906	72981	73057	73133	73208	73284	950
960	73360	73435	73511	73586	73662	73738	73813	73889	73964	74040	960
970	74115	74190	74266	74341	74417	74492	74567	74643	74718	74793	970
980	74869	74944	75019	75095	75170	75245	75320	75395	75471	75546	980
990	75621	75696	75771	75847	75922	75997	76072	76147	76223	76298	990
1000	76373										1000

Appendix 4.3 Standard Thermal Electromotive Force of J

Type J

Conform to IEC584-1(1977), IEC584-2(1982), JIS C1602-1995

Unit μV

Temperature (°C)	0	-1	-2	-3	-4	-5	-6	-7	-8	-9	Temperature (°C)
-210	-8095										-210
-200	-7890	-7912	-7934	-7955	-7976	-7996	-8017	-8037	-8057	-8076	-200
-190	-7659	-7683	-7707	-7731	-7755	-7778	-7801	-7824	-7846	-7868	-190
-180	-7403	-7429	-7456	-7482	-7508	-7534	-7559	-7585	-7610	-7634	-180
-170	-7123	-7152	-7181	-7209	-7237	-7265	-7293	-7321	-7348	-7376	-170
-160	-6821	-6853	-6883	-6914	-6944	-6975	-7005	-7035	-7064	-7094	-160
-150	-6500	-6533	-6566	-6598	-6631	-6663	-6695	-6727	-6759	-6790	-150
-140	-6159	-6194	-6229	-6263	-6298	-6332	-6366	-6400	-6433	-6467	-140
-130	-5801	-5838	-5874	-5910	-5946	-5982	-6018	-6054	-6089	-6124	-130
-120	-5426	-5465	-5503	-5541	-5578	-5616	-5653	-5690	-5727	-5764	-120
-110	-5037	-5076	-5116	-5155	-5194	-5233	-5272	-5311	-5350	-5388	-110
-100	-4633	-4674	-4714	-4755	-4796	-4836	-4877	-4917	-4957	-4997	-100
-90	-4215	-4257	-4300	-4342	-4384	-4425	-4467	-4509	-4550	-4591	-90
-80	-3786	-3829	-3872	-3916	-3959	-4002	-4045	-4088	-4130	-4173	-80
-70	-3344	-3389	-3434	-3478	-3522	-3566	-3610	-3654	-3698	-3742	-70
-60	-2893	-2938	-2984	-3029	-3075	-3120	-3165	-3210	-3255	-3300	-60
-50	-2431	-2478	-2524	-2571	-2617	-2663	-2709	-2755	-2801	-2847	-50
-40	-1961	-2008	-2055	-2103	-2150	-2197	-2244	-2291	-2338	-2385	-40
-30	-1482	-1530	-1578	-1626	-1674	-1722	-1770	-1818	-1865	-1913	-30
-20	-995	-1044	-1093	-1142	-1190	-1239	-1288	-1336	-1385	-1433	-20
-10	-501	-550	-600	-650	-699	-749	-798	-847	-896	-946	-10
0	0	-50	-101	-151	-201	-251	-301	-351	-401	-451	0
Temperature (°C)	0	1	2	3	4	5	6	7	8	9	Temperature (°C)
0	0	50	101	151	202	253	303	354	405	456	0
10	507	558	609	660	711	762	814	865	916	968	10
20	1019	1071	1122	1174	1226	1277	1329	1381	1433	1485	20
30	1537	1589	1641	1693	1745	1797	1849	1902	1954	2006	30
40	2059	2111	2164	2216	2269	2322	2374	2427	2480	2532	40
50	2585	2638	2691	2744	2797	2850	2903	2956	3009	3062	50
60	3116	3169	3222	3275	3329	3382	3436	3489	3543	3596	60
70	3650	3703	3757	3810	3864	3918	3971	4025	4079	4133	70
80	4187	4240	4294	4348	4402	4456	4510	4564	4618	4672	80
90	4726	4781	4835	4889	4943	4997	5052	5106	5160	5215	90
100	5269	5323	5378	5432	5487	5541	5595	5650	5705	5759	100
110	5814	5868	5923	5977	6032	6087	6141	6196	6251	6306	110
120	6360	6415	6470	6525	6579	6634	6689	6744	6799	6854	120
130	6909	6964	7019	7074	7129	7184	7239	7294	7349	7404	130
140	7459	7514	7569	7624	7679	7734	7789	7844	7900	7955	140
150	8010	8065	8120	8175	8231	8286	8341	8396	8452	8507	150
160	8562	8618	8673	8728	8783	8839	8894	8949	9005	9060	160
170	9115	9171	9226	9282	9337	9392	9448	9503	9559	9614	170
180	9669	9725	9780	9836	9891	9947	10002	10057	10113	10168	180
190	10224	10279	10335	10390	10446	10501	10557	10612	10668	10723	190

Type J

Conform to IEC584-1(1977), IEC584-2(1982), JIS C1602-1995

Unit μ V

Temperature (°C)	0	1	2	3	4	5	6	7	8	9	Temperature (°C)
200	10779	10834	10890	10945	11001	11056	11112	11167	11223	11278	200
210	11334	11389	11445	11501	11556	11612	11667	11723	11778	11834	210
220	11889	11945	12000	12056	12111	12167	12222	12278	12334	12389	220
230	12445	12500	12556	12611	12667	12722	12778	12833	12889	12944	230
240	13000	13056	13111	13167	13222	13278	13333	13389	13444	13500	240
250	13555	13611	13666	13722	13777	13833	13888	13944	13999	14055	250
260	14110	14166	14221	14277	14332	14388	14443	14499	14554	14609	260
270	14665	14720	14776	14831	14887	14942	14998	15053	15109	15164	270
280	15219	15275	15330	15386	15441	15496	15552	15607	15663	15718	280
290	15773	15829	15884	15940	15995	16050	16106	16161	16216	16272	290
300	16327	16383	16438	16493	16549	16604	16659	16715	16770	16825	300
310	16881	16936	16991	17046	17102	17157	17212	17268	17323	17378	310
320	17434	17489	17544	17599	17655	17710	17765	17820	17876	17931	320
330	17986	18041	18097	18152	18207	18262	18318	18373	18428	18483	330
340	18538	18594	18649	18704	18759	18814	18870	18925	18980	19035	340
350	19090	19146	19201	19256	19311	19366	19422	19477	19532	19587	350
360	19642	19697	19753	19808	19863	19918	19973	20028	20083	20139	360
370	20194	20249	20304	20359	20414	20469	20525	20580	20635	20690	370
380	20745	20800	20855	20911	20966	21021	21076	21131	21186	21241	380
390	21297	21352	21407	21462	21517	21572	21627	21683	21738	21793	390
400	21848	21903	21958	22014	22069	22124	22179	22234	22289	22345	400
410	22400	22455	22510	22565	22620	22676	22731	22786	22841	22896	410
420	22952	23007	23062	23117	23172	23228	23283	23338	23393	23449	420
430	23504	23559	23614	23670	23725	23780	23835	23891	23946	24001	430
440	24057	24112	24167	24223	24278	24333	24389	24444	24499	24555	440
450	24610	24665	24721	24776	24832	24887	24943	24998	25053	25109	450
460	25164	25220	25275	25331	25386	25442	25497	25553	25608	25664	460
470	25720	25775	25831	25886	25942	25998	26053	26109	26165	26220	470
480	26276	26332	26387	26443	26499	26555	26610	26666	26722	26778	480
490	26834	26889	26945	27001	27057	27113	27169	27225	27281	27337	490
500	27393	27449	27505	27561	27617	27673	27729	27785	27841	27897	500
510	27953	28010	28066	28122	28178	28234	28291	28347	28403	28460	510
520	28516	28572	28629	28685	28741	28798	28854	28911	28967	29024	520
530	29080	29137	29194	29250	29307	29363	29420	29477	29534	29590	530
540	29647	29704	29761	29818	29874	29931	29988	30045	30102	30159	540
550	30216	30273	30330	30387	30444	30502	30559	30616	30673	30730	550
560	30788	30845	30902	30960	31017	31074	31132	31189	31247	31304	560
570	31362	31419	31477	31535	31592	31650	31708	31766	31823	31881	570
580	31939	31997	32055	32113	32171	32229	32287	32345	32403	32461	580
590	32519	32577	32636	32694	32752	32810	32869	32927	32985	33044	590
600	33102	33161	33219	33278	33337	33395	33454	33513	33571	33630	600
610	33689	33748	33807	33866	33925	33984	34043	34102	34161	34220	610
620	34279	34338	34397	34457	34516	34575	34635	34694	34754	34813	620
630	34873	34932	34992	35051	35111	35171	35230	35290	35350	35410	630
640	35470	35530	35590	35650	35710	35770	35830	35890	35950	36010	640

Type J

Conform to IEC584-1(1977), IEC584-2(1982), JIS C1602-1995

Unit μV

Temperature (°C)	0	1	2	3	4	5	6	7	8	9	Temperature (°C)
650	36071	36131	36191	36252	36312	36373	36433	36494	36554	36615	650
660	36675	36736	36797	36858	36918	36979	37040	37101	37162	37223	660
670	37284	37345	37406	37467	37528	37590	37651	37712	37773	37835	670
680	37896	37958	38019	38081	38142	38204	38265	38327	38389	38450	680
690	38512	38574	38636	38698	38760	38822	38884	38946	39008	39070	690
700	39132	39194	39256	39318	39381	39443	39505	39568	39630	39693	700
710	39755	39818	39880	39943	40005	40068	40131	40193	40256	40319	710
720	40382	40445	40508	40570	40633	40696	40759	40822	40886	40949	720
730	41012	41075	41138	41201	41265	41328	41391	41455	41518	41581	730
740	41645	41708	41772	41835	41899	41962	42026	42090	42153	42217	740
750	42281	42344	42408	42472	42536	42599	42663	42727	42791	42855	750
760	42919	42983	43047	43111	43175	43239	43303	43367	43431	43495	760
770	43559	43624	43688	43752	43817	43881	43945	44010	44074	44139	770
780	44203	44267	44332	44396	44461	44525	44590	44655	44719	44784	780
790	44848	44913	44977	45042	45107	45171	45236	45301	45365	45430	790
800	45494	45559	45624	45688	45753	45818	45882	45947	46011	46076	800
810	46141	46205	46270	46334	46399	46464	46528	46593	46657	46722	810
820	46786	46851	46915	46980	47044	47109	47173	47238	47302	47367	820
830	47431	47495	47560	47624	47688	47753	47817	47881	47946	48010	830
840	48074	48138	48202	48267	48331	48395	48459	48523	48587	48651	840
850	48715	48779	48843	48907	48971	49034	49098	49162	49226	49290	850
860	49353	49417	49481	49544	49608	49672	49735	49799	49862	49926	860
870	49989	50052	50116	50179	50243	50306	50369	50432	50495	50559	870
880	50622	50685	50748	50811	50874	50937	51000	51063	51126	51189	880
890	51251	51314	51377	51439	51502	51565	51627	51690	51752	51815	890
900	51877	51940	52002	52064	52127	52189	52251	52314	52376	52438	900
910	52500	52562	52624	52686	52748	52810	52872	52934	52996	53057	910
920	53119	53181	53243	53304	53366	53427	53489	53550	53612	53673	920
930	53735	53796	53857	53919	53980	54041	54102	54164	54225	54286	930
940	54347	54408	54469	54530	54591	54652	54713	54773	54834	54895	940
950	54956	55016	55077	55138	55198	55259	55319	55380	55440	55501	950
960	55561	55622	55682	55742	55803	55863	55923	55983	56043	56104	960
970	56164	56224	56284	56344	56404	56464	56524	56584	56643	56703	970
980	56763	56823	56883	56942	57002	57062	57121	57181	57240	57300	980
990	57360	57419	57479	57538	57597	57657	57716	57776	57835	57894	990
1000	57953	58013	58072	58131	58190	58249	58309	58368	58427	58486	1000
1010	58545	58604	58663	58722	58781	58840	58899	58957	59016	59075	1010
1020	59134	59193	59252	59310	59369	59428	59487	59545	59604	59663	1020
1030	59721	59780	59838	59897	59956	60014	60073	60131	60190	60248	1030
1040	60307	60365	60423	60482	60540	60599	60657	60715	60774	60832	1040
1050	60890	60949	61007	61065	61123	61182	61240	61298	61356	61415	1050
1060	61473	61531	61589	61647	61705	61763	61822	61880	61938	61996	1060
1070	62054	62112	62170	62228	62286	62344	62402	62460	62518	62576	1070
1080	62634	62692	62750	62808	62866	62924	62982	63040	63098	63156	1080
1090	63214	63271	63329	63387	63445	63503	63561	63619	63677	63734	1090

Type J

Conform to IEC584-1(1977), IEC584-2(1982), JIS C1602-1995

Unit μV

Temperature (°C)	0	1	2	3	4	5	6	7	8	9	Temperature (°C)
1100	63792	63850	63908	63966	64024	64081	64139	64197	64255	64313	1100
1110	64370	64428	64486	64544	64602	64659	64717	64775	64833	64890	1110
1120	64948	65006	65064	65121	65179	65237	65295	65352	65410	65468	1120
1130	65525	65583	65641	65699	65756	65814	65872	65929	65987	66045	1130
1140	66102	66160	66218	66275	66333	66391	66448	66506	66564	66621	1140
1150	66679	66737	66794	66852	66910	66967	67025	67082	67140	67198	1150
1160	67255	67313	67370	67428	67486	67543	67601	67658	67716	67773	1160
1170	67831	67888	67946	68003	68061	68119	68176	68234	68291	68348	1170
1180	68406	68463	68521	68578	68636	68693	68751	68808	68865	68923	1180
1190	68980	69037	69095	69152	69209	69267	69324	69381	69439	69496	1190
1200	69553										1200

REMARK

Standard contact temperature is 0°C.

Appendix 4.4 Standard Thermal Electromotive Force of T

Type T

 Unit μV

Conform to IEC584-1(1977), IEC584-2(1982), JIS C1602-1995

Temperature (°C)	0	-1	-2	-3	-4	-5	-6	-7	-8	-9	Temperature (°C)
-270	-6258										-270
-260	-6232	-6236	-6239	-6242	-6245	-6248	-6251	-6253	-6255	-6256	-260
-250	-6180	-6187	-6193	-6198	-6204	-6209	-6214	-6219	-6223	-6228	-250
-240	-6105	-6114	-6122	-6130	-6138	-6146	-6153	-6160	-6167	-6174	-240
-230	-6007	-6017	-6028	-6038	-6049	-6059	-6068	-6078	-6087	-6096	-230
-220	-5888	-5901	-5914	-5926	-5938	-5950	-5962	-5973	-5985	-5996	-220
-210	-5753	-5767	-5782	-5795	-5809	-5823	-5836	-5850	-5863	-5876	-210
-200	-5603	-5619	-5634	-5650	-5665	-5680	-5695	-5710	-5724	-5739	-200
-190	-5439	-5456	-5473	-5489	-5506	-5523	-5539	-5555	-5571	-5587	-190
-180	-5261	-5279	-5297	-5316	-5334	-5351	-5369	-5387	-5404	-5421	-180
-170	-5070	-5089	-5109	-5128	-5148	-5167	-5186	-5205	-5224	-5242	-170
-160	-4865	-4886	-4907	-4928	-4949	-4969	-4989	-5010	-5030	-5050	-160
-150	-4648	-4671	-4693	-4715	-4737	-4759	-4780	-4802	-4823	-4844	-150
-140	-4419	-4443	-4466	-4489	-4512	-4535	-4558	-4581	-4604	-4626	-140
-130	-4177	-4202	-4226	-4251	-4275	-4300	-4324	-4348	-4372	-4395	-130
-120	-3923	-3949	-3975	-4000	-4026	-4052	-4077	-4102	-4127	-4152	-120
-110	-3657	-3684	-3711	-3738	-3765	-3791	-3818	-3844	-3871	-3897	-110
-100	-3379	-3407	-3435	-3463	-3491	-3519	-3547	-3574	-3602	-3629	-100
-90	-3089	-3118	-3148	-3177	-3206	-3235	-3264	-3293	-3322	-3350	-90
-80	-2788	-2818	-2849	-2879	-2910	-2940	-2970	-3000	-3030	-3059	-80
-70	-2476	-2507	-2539	-2571	-2602	-2633	-2664	-2695	-2726	-2757	-70
-60	-2153	-2186	-2218	-2251	-2283	-2316	-2348	-2380	-2412	-2444	-60
-50	-1819	-1853	-1887	-1920	-1954	-1987	-2021	-2054	-2087	-2120	-50
-40	-1475	-1510	-1545	-1579	-1614	-1648	-1683	-1717	-1751	-1785	-40
-30	-1121	-1157	-1192	-1228	-1264	-1299	-1335	-1370	-1405	-1440	-30
-20	-757	-794	-830	-867	-904	-940	-976	-1013	-1049	-1085	-20
-10	-383	-421	-459	-496	-534	-571	-608	-646	-683	-720	-10
0	0	-39	-77	-116	-154	-193	-231	-269	-307	-345	0
Temperature (°C)	0	1	2	3	4	5	6	7	8	9	Temperature (°C)
0	0	39	78	117	156	195	234	273	312	352	0
10	391	431	470	510	549	589	629	669	709	749	10
20	790	830	870	911	951	992	1033	1074	1114	1155	20
30	1196	1238	1279	1320	1362	1403	1445	1486	1528	1570	30
40	1612	1654	1696	1738	1780	1823	1865	1908	1950	1993	40
50	2036	2079	2122	2165	2208	2251	2294	2338	2381	2425	50
60	2468	2512	2556	2600	2643	2687	2732	2776	2820	2864	60
70	2909	2953	2998	3043	3087	3132	3177	3222	3267	3312	70
80	3358	3403	3448	3494	3539	3585	3631	3677	3722	3768	80
90	3814	3860	3907	3953	3999	4046	4092	4138	4185	4232	90
100	4279	4325	4372	4419	4466	4513	4561	4608	4655	4702	100
110	4750	4798	4845	4893	4941	4988	5036	5084	5132	5180	110
120	5228	5277	5325	5373	5422	5470	5519	5567	5616	5665	120
130	5714	5763	5812	5861	5910	5959	6008	6057	6107	6156	130
140	6206	6255	6305	6355	6404	6454	6504	6554	6604	6654	140
150	6704	6754	6805	6855	6905	6956	7006	7057	7107	7158	150
160	7209	7260	7310	7361	7412	7463	7515	7566	7617	7668	160
170	7720	7771	7823	7874	7926	7977	8029	8081	8133	8185	170
180	8237	8289	8341	8393	8445	8497	8550	8602	8654	8707	180
190	8759	8812	8865	8917	8970	9023	9076	9129	9182	9235	190

Type T

Conform to IEC584-1(1977), IEC584-2(1982), JIS C1602-1995

Unit μV

Temperature (°C)	0	1	2	3	4	5	6	7	8	9	Temperature (°C)
200	9288	9341	9395	9448	9501	9555	9608	9662	9715	9769	200
210	9822	9876	9930	9984	10038	10092	10146	10200	10254	10308	210
220	10362	10417	10471	10525	10580	10634	10689	10743	10798	10853	220
230	10907	10962	11017	11072	11127	11182	11237	11292	11347	11403	230
240	11458	11513	11569	11624	11680	11735	11791	11846	11902	11958	240
250	12013	12069	12125	12181	12237	12293	12349	12405	12461	12518	250
260	12574	12630	12687	12743	12799	12856	12912	12969	13026	13082	260
270	13139	13196	13253	13310	13366	13423	13480	13537	13595	13652	270
280	13709	13766	13823	13881	13938	13995	14053	14110	14168	14226	280
290	14283	14341	14399	14456	14514	14572	14630	14688	14746	14804	290
300	14862	14920	14978	15036	15095	15153	15211	15270	15328	15386	300
310	15445	15503	15562	15621	15679	15738	15797	15856	15914	15973	310
320	16032	16091	16150	16209	16268	16327	16387	16446	16505	16564	320
330	16624	16683	16742	16802	16861	16921	16980	17040	17100	17159	330
340	17219	17279	17339	17399	17458	17518	17578	17638	17698	17759	340
350	17819	17879	17939	17999	18060	18120	18180	18241	18301	18362	350
360	18422	18483	18543	18604	18665	18725	18786	18847	18908	18969	360
370	19030	19091	19152	19213	19274	19335	19396	19457	19518	19579	370
380	19641	19702	19763	19825	19886	19947	20009	20070	20132	20193	380
390	20255	20317	20378	20440	20502	20563	20625	20687	20748	20810	390
400	20872										400

REMARK

Standard contact temperature is 0°C.

Appendix 4.5 Standard Thermal Electromotive Force of B

Type B

 Unit μV

Conform to IEC584-1(1977), IEC584-2(1982), JIS C1602-1995

Temperature (°C)	0	1	2	3	4	5	6	7	8	9	Temperature (°C)
0	0	0	0	-1	-1	-1	-1	-1	-2	-2	0
10	-2	-2	-2	-2	-2	-2	-2	-2	-3	-3	10
20	-3	-3	-3	-3	-3	-2	-2	-2	-2	-2	20
30	-2	-2	-2	-2	-2	-1	-1	-1	-1	-1	30
40	0	0	0	0	0	1	1	1	2	2	40
50	2	3	3	3	4	4	4	5	5	6	50
60	6	7	7	8	8	9	9	10	10	11	60
70	11	12	12	13	14	14	15	15	16	17	70
80	17	18	19	20	20	21	22	22	23	24	80
90	25	26	26	27	28	29	30	31	31	32	90
100	33	34	35	36	37	38	39	40	41	42	100
110	43	44	45	46	47	48	49	50	51	52	110
120	53	55	56	57	58	59	60	62	63	64	120
130	65	66	68	69	70	72	73	74	75	77	130
140	78	79	81	82	84	85	86	88	89	91	140
150	92	94	95	96	98	99	101	102	104	106	150
160	107	109	110	112	113	115	117	118	120	122	160
170	123	125	127	128	130	132	134	135	137	139	170
180	141	142	144	146	148	150	151	153	155	157	180
190	159	161	163	165	166	168	170	172	174	176	190
200	178	180	182	184	186	188	190	192	195	197	200
210	199	201	203	205	207	209	212	214	216	218	210
220	220	222	225	227	229	231	234	236	238	241	220
230	243	245	248	250	252	255	257	259	262	264	230
240	267	269	271	274	276	279	281	284	286	289	240
250	291	294	296	299	301	304	307	309	312	314	250
260	317	320	322	325	328	330	333	336	338	341	260
270	344	347	349	352	355	358	360	363	366	369	270
280	372	375	377	380	383	386	389	392	395	398	280
290	401	404	407	410	413	416	419	422	425	428	290
300	431	434	437	440	443	446	449	452	455	458	300
310	462	465	468	471	474	478	481	484	487	490	310
320	494	497	500	503	507	510	513	517	520	523	320
330	527	530	533	537	540	544	547	550	554	557	330
340	561	564	568	571	575	578	582	585	589	592	340
350	596	599	603	607	610	614	617	621	625	628	350
360	632	636	639	643	647	650	654	658	662	665	360
370	669	673	677	680	684	688	692	696	700	703	370
380	707	711	715	719	723	727	731	735	738	742	380
390	746	750	754	758	762	766	770	774	778	782	390
400	787	791	795	799	803	807	811	815	819	824	400
410	828	832	836	840	844	849	853	857	861	866	410
420	870	874	878	883	887	891	896	900	904	909	420
430	913	917	922	926	930	935	939	944	948	953	430
440	957	961	966	970	975	979	984	988	993	997	440
450	1002	1007	1011	1016	1020	1025	1030	1034	1039	1043	450
460	1048	1053	1057	1062	1067	1071	1076	1081	1086	1090	460
470	1095	1100	1105	1109	1114	1119	1124	1129	1133	1138	470
480	1143	1148	1153	1158	1163	1167	1172	1177	1182	1187	480
490	1192	1197	1202	1207	1212	1217	1222	1227	1232	1237	490

Type B

Conform to IEC584-1(1977), IEC584-2(1982), JIS C1602-1995

Unit μ V

Temperature (°C)	0	1	2	3	4	5	6	7	8	9	Temperature (°C)
500	1242	1247	1252	1257	1262	1267	1272	1277	1282	1288	500
510	1293	1298	1303	1308	1313	1318	1324	1329	1334	1339	510
520	1344	1350	1355	1360	1365	1371	1376	1381	1387	1392	520
530	1397	1402	1408	1413	1418	1424	1429	1435	1440	1445	530
540	1451	1456	1462	1467	1472	1478	1483	1489	1494	1500	540
550	1505	1511	1516	1522	1527	1533	1539	1544	1550	1555	550
560	1561	1566	1572	1578	1583	1589	1595	1600	1606	1612	560
570	1617	1623	1629	1634	1640	1646	1652	1657	1663	1669	570
580	1675	1680	1686	1692	1698	1704	1709	1715	1721	1727	580
590	1733	1739	1745	1750	1756	1762	1768	1774	1780	1786	590
600	1792	1798	1804	1810	1816	1822	1828	1834	1840	1846	600
610	1852	1858	1864	1870	1876	1882	1888	1894	1901	1907	610
620	1913	1919	1925	1931	1937	1944	1950	1956	1962	1968	620
630	1975	1981	1987	1993	1999	2006	2012	2018	2025	2031	630
640	2037	2043	2050	2056	2062	2069	2075	2082	2088	2094	640
650	2101	2107	2113	2120	2126	2133	2139	2146	2152	2158	650
660	2165	2171	2178	2184	2191	2197	2204	2210	2217	2224	660
670	2230	2237	2243	2250	2256	2263	2270	2276	2283	2289	670
680	2296	2303	2309	2316	2323	2329	2336	2343	2350	2356	680
690	2363	2370	2376	2383	2390	2397	2403	2410	2417	2424	690
700	2431	2437	2444	2451	2458	2456	2472	2479	2485	2492	700
710	2499	2506	2513	2520	2527	2534	2541	2548	2555	2562	710
720	2569	2576	2583	2590	2597	2604	2611	2618	2625	2632	720
730	2639	2646	2653	2660	2667	2674	2681	2688	2696	2703	730
740	2710	2717	2724	2731	2738	2746	2753	2760	2767	2775	740
750	2782	2789	2796	2803	2811	2818	2825	2833	2840	2847	750
760	2854	2862	2869	2876	2884	2891	2898	2906	2913	2921	760
770	2928	2935	2943	2950	2958	2965	2973	2980	2987	2995	770
780	3002	3010	3017	3025	3032	3040	3047	3055	3062	3070	780
790	3078	3085	3093	3100	3108	3116	3123	3131	3138	3146	790
800	3154	3161	3169	3177	3184	3192	3200	3207	3215	3223	800
810	3230	3238	3246	3254	3261	3269	3277	3285	3292	3300	810
820	3308	3316	3324	3331	3339	3347	3355	3363	3371	3379	820
830	3386	3394	3402	3410	3418	3426	3434	3442	3450	3458	830
840	3466	3474	3482	3490	3498	3506	3514	3522	3530	3538	840
850	3546	3554	3562	3570	3578	3586	3594	3602	3610	3618	850
860	3626	3634	3643	3651	3659	3667	3675	3683	3692	3700	860
870	3708	3716	3724	3732	3741	3749	3757	3765	3774	3782	870
880	3790	3798	3807	3815	3823	3832	3840	3848	3857	3865	880
890	3873	3882	3890	3898	3907	3915	3923	3932	3940	3949	890
900	3957	3965	3974	3982	3991	3999	4008	4016	4024	4033	900
910	4041	4050	4058	4067	4075	4084	4093	4101	4110	4118	910
920	4127	4135	4144	4152	4161	4170	4178	4187	4195	4204	920
930	4213	4221	4230	4239	4247	4256	4265	4273	4282	4291	930
940	4299	4308	4317	4326	4334	4343	4352	4360	4369	4378	940
950	4387	4396	4404	4413	4422	4431	4440	4448	4457	4466	950
960	4475	4484	4493	4501	4510	4519	4528	4537	4546	4555	960
970	4564	4573	4582	4591	4599	4608	4617	4626	4635	4644	970
980	4653	4662	4671	4680	4689	4698	4707	4716	4725	4734	980
990	4743	4753	4762	4771	4780	4789	4798	4807	4816	4825	990

Type B

Conform to IEC584-1(1977), IEC584-2(1982), JIS C1602-1995

Unit μV

Temperature (°C)	0	1	2	3	4	5	6	7	8	9	Temperature (°C)
1000	4834	4843	4853	4862	4871	4880	4889	4898	4908	4917	1000
1010	4926	4935	4944	4954	4963	4972	4981	4990	5000	5009	1010
1020	5018	5027	5037	5046	5055	5065	5074	5083	5092	5102	1020
1030	5111	5120	5130	5139	5148	5158	5167	5176	5186	5195	1030
1040	5205	5214	5223	5233	5242	5252	5261	5270	5280	5289	1040
1050	5299	5308	5318	5327	5337	5346	5356	5365	5375	5384	1050
1060	5394	5403	5413	5422	5432	5441	5451	5460	5470	5480	1060
1070	5489	5499	5508	5518	5528	5537	5547	5556	5566	5576	1070
1080	5585	5595	5605	5614	5624	5634	5643	5653	5663	5672	1080
1090	5682	5692	5702	5711	5721	5731	5740	5750	5760	5770	1090
1100	5780	5789	5799	5809	5819	5828	5838	5848	5858	5868	1100
1110	5878	5887	5897	5907	5917	5927	5937	5947	5956	5966	1110
1120	5976	5986	5996	6006	6016	6026	6036	6046	6055	6065	1120
1130	6075	6085	6095	6105	6115	6125	6135	6145	6155	6165	1130
1140	6175	6185	6195	6205	6215	6225	6235	6245	6256	6266	1140
1150	6276	6286	6296	6306	6316	6326	6336	6346	6356	6367	1150
1160	6377	6387	6397	6407	6417	6427	6438	6448	6458	6468	1160
1170	6478	6488	6499	6509	6519	6529	6539	6550	6560	6570	1170
1180	6580	6591	6601	6611	6621	6632	6642	6652	6663	6673	1180
1190	6683	6693	6704	6714	6724	6735	6745	6755	6766	6776	1190
1200	6786	6797	6807	6818	6828	6838	6849	6859	6869	6880	1200
1210	6890	6901	6911	6922	6932	6942	6953	6963	6974	6984	1210
1220	6995	7005	7016	7026	7037	7047	7058	7068	7079	7089	1220
1230	7100	7110	7121	7131	7142	7152	7163	7173	7184	7194	1230
1240	7205	7216	7226	7237	7247	7258	7269	7279	7290	7300	1240
1250	7311	7322	7332	7343	7353	7364	7375	7385	7396	7407	1250
1260	7417	7428	7439	7449	7460	7471	7482	7492	7503	7514	1260
1270	7524	7535	7546	7557	7567	7578	7589	7600	7610	7621	1270
1280	7632	7643	7653	7664	7675	7686	7697	7707	7718	7729	1280
1290	7740	7751	7761	7772	7783	7794	7805	7816	7827	7837	1290
1300	7848	7859	7870	7881	7892	7903	7914	7924	7935	7946	1300
1310	7957	7968	7979	7990	8001	8012	8023	8034	8045	8058	1310
1320	8066	8077	8088	8099	8110	8121	8132	8143	8154	8165	1320
1330	8176	8187	8198	8209	8220	8231	8242	8253	8264	8275	1330
1340	8286	8298	8309	8320	8331	8342	8353	8364	8375	8386	1340
1350	8397	8408	8419	8430	8441	8453	8464	8475	8486	8497	1350
1360	8508	8519	8530	8542	8553	8564	8575	8586	8597	8608	1360
1370	8620	8631	8642	8653	8664	8675	8687	8698	8709	8720	1370
1380	8731	8743	8754	8765	8776	8787	8799	8810	8821	8832	1380
1390	8844	8855	8866	8877	8889	8900	8911	8922	8934	8945	1390
1400	8956	8967	8979	8990	9001	9013	9024	9035	9047	9058	1400
1410	9069	9080	9092	9103	9114	9126	9137	9148	9160	9171	1410
1420	9182	9194	9205	9216	9228	9239	9251	9262	9273	9285	1420
1430	9296	9307	9319	9330	9342	9353	9364	9376	9387	9398	1430
1440	9410	9421	9433	9444	9456	9467	9478	9490	9501	9513	1440
1450	9524	9536	9547	9558	9570	9581	9593	9604	9616	9627	1450
1460	9639	9650	9662	9673	9684	9696	9707	9719	9730	9742	1460
1470	9753	9765	9776	9788	9799	9811	9822	9834	9845	9857	1470
1480	9868	9880	9891	9903	9914	9926	9937	9949	9961	9972	1480
1490	9984	9995	10007	10018	10030	10041	10053	10064	10076	10088	1490

Type B

 Unit μ V

Conform to IEC584-1(1977), IEC584-2(1982), JIS C1602-1995

Temperature (°C)	0	1	2	3	4	5	6	7	8	9	Temperature (°C)
1500	10099	10111	10122	10134	10145	10157	10168	10180	10192	10203	1500
1510	10215	10226	10238	10249	10261	10273	10284	10296	10307	10319	1510
1520	10331	10342	10354	10365	10377	10389	10400	10412	10423	10435	1520
1530	10447	10458	10470	10482	10493	10505	10516	10528	10540	10551	1530
1540	10563	10575	10586	10598	10609	10621	10633	10644	10656	10668	1540
1550	10679	10691	10703	10714	10726	10738	10749	10761	10773	10784	1550
1560	10796	10808	10819	10831	10843	10854	10866	10877	10889	10901	1560
1570	10913	10924	10936	10948	10959	10971	10983	10994	11006	11018	1570
1580	11029	11041	11053	11064	11076	11088	11099	11111	11123	11134	1580
1590	11146	11158	11169	11181	11193	11205	11216	11228	11240	11251	1590
1600	11263	11275	11286	11298	11310	11321	11333	11345	11357	11368	1600
1610	11380	11392	11403	11415	11427	11438	11450	11462	11474	11485	1610
1620	11497	11509	11520	11532	11544	11555	11567	11579	11591	11602	1620
1630	11614	11626	11637	11649	11661	11673	11684	11696	11708	11719	1630
1640	11731	11743	11754	11766	11778	11790	11801	11813	11825	11836	1640
1650	11848	11860	11871	11883	11895	11907	11918	11930	11942	11953	1650
1660	11965	11977	11988	12000	12012	12024	12035	12047	12059	12070	1660
1670	12082	12094	12105	12117	12129	12141	12152	12164	12176	12187	1670
1680	12199	12211	12222	12234	12246	12257	12269	12281	12292	12304	1680
1690	12316	12327	12339	12351	12363	12374	12386	12398	12409	12421	1690
1700	12433	12444	12456	12468	12479	12491	12503	12514	12526	12538	1700
1710	12549	12561	12572	12584	12596	12607	12619	12631	12642	12654	1710
1720	12666	12677	12689	12701	12712	12724	12736	12747	12759	12770	1720
1730	12782	12794	12805	12817	12829	12840	12852	12863	12875	12887	1730
1740	12898	12910	12921	12933	12945	12956	12968	12980	12991	13003	1740
1750	13014	13026	13037	13049	13061	13072	13084	13095	13107	13119	1750
1760	13130	13142	13153	13165	13176	13188	13200	13211	13223	13234	1760
1770	13246	13257	13269	13280	13292	13304	13315	13327	13338	13350	1770
1780	13361	13373	13384	13396	13407	13419	13430	13442	13453	13465	1780
1790	13476	13488	13499	13511	13522	13534	13545	13557	13568	13580	1790
1800	13591	13603	13614	13626	13637	13649	13660	13672	13683	13694	1800
1810	13706	13717	13729	13740	13752	13763	13775	13786	13797	13809	1810
1820	13820										1820

REMARK

Standard contact temperature is 0°C.

Appendix 4.6 Standard Thermal Electromotive Force of R

Type R

Conform to IEC584-1(1977), IEC584-2(1982), JIS C1602-1995

Unit μV

Temperature (°C)	0	-1	-2	-3	-4	-5	-6	-7	-8	-9	Temperature (°C)
-50	-226										-50
-40	-188	-192	-196	-200	-204	-208	-211	-215	-219	-223	-40
-30	-145	-150	-154	-158	-163	-167	-171	-175	-180	-184	-30
-20	-100	-105	-109	-114	-119	-123	-128	-132	-137	-141	-20
-10	-51	-56	-61	-66	-71	-76	-81	-86	-91	-95	-10
0	0	-5	-11	-16	-21	-26	-31	-36	-41	-46	0
Temperature (°C)	0	1	2	3	4	5	6	7	8	9	Temperature (°C)
0	0	5	11	16	21	27	32	38	43	49	0
10	54	60	65	71	77	82	88	94	100	105	10
20	111	117	123	129	135	141	147	153	159	165	20
30	171	177	183	189	195	201	207	214	220	226	30
40	232	239	245	251	258	264	271	277	284	290	40
50	296	303	310	316	323	329	336	343	349	356	50
60	363	369	376	383	390	397	403	410	417	424	60
70	431	438	445	452	459	466	473	480	487	494	70
80	501	508	516	523	530	537	544	552	559	566	80
90	573	581	588	595	603	610	618	625	632	640	90
100	647	655	662	670	677	685	693	700	708	715	100
110	723	731	738	746	754	761	769	777	785	792	110
120	800	808	816	824	832	839	847	855	863	871	120
130	879	887	895	903	911	919	927	935	943	951	130
140	959	967	976	984	992	1000	1008	1016	1025	1033	140
150	1041	1049	1058	1066	1074	1082	1091	1099	1107	1116	150
160	1124	1132	1141	1149	1158	1166	1175	1183	1191	1200	160
170	1208	1217	1225	1234	1242	1251	1260	1268	1277	1285	170
180	1294	1303	1311	1320	1329	1337	1346	1355	1363	1372	180
190	1381	1389	1398	1407	1416	1425	1433	1442	1451	1460	190
200	1469	1477	1486	1495	1504	1513	1522	1531	1540	1549	200
210	1558	1567	1575	1584	1593	1602	1611	1620	1629	1639	210
220	1648	1657	1666	1675	1684	1693	1702	1711	1720	1729	220
230	1739	1748	1757	1766	1775	1784	1794	1803	1812	1821	230
240	1831	1840	1849	1858	1868	1877	1886	1895	1905	1914	240
250	1923	1933	1942	1951	1961	1970	1980	1989	1998	2008	250
260	2017	2027	2036	2046	2055	2064	2074	2083	2093	2102	260
270	2112	2121	2131	2140	2150	2159	2169	2179	2188	2198	270
280	2207	2217	2226	2236	2246	2255	2265	2275	2284	2294	280
290	2304	2313	2323	2333	2342	2352	2362	2371	2381	2391	290
300	2401	2410	2420	2430	2440	2449	2459	2469	2479	2488	300
310	2498	2508	2518	2528	2538	2547	2557	2567	2577	2587	310
320	2597	2607	2617	2626	2636	2646	2656	2666	2676	2686	320
330	2696	2706	2716	2726	2736	2746	2756	2766	2776	2786	330
340	2796	2806	2816	2826	2836	2846	2856	2866	2876	2886	340
350	2896	2906	2916	2926	2937	2947	2957	2967	2977	2987	350
360	2997	3007	3018	3028	3038	3048	3058	3068	3079	3089	360
370	3099	3109	3119	3130	3140	3150	3160	3171	3181	3191	370
380	3201	3212	3222	3232	3242	3253	3263	3273	3284	3294	380
390	3304	3315	3325	3335	3346	3356	3366	3377	3387	3397	390

Type R

Conform to IEC584-1(1977), IEC584-2(1982), JIS C1602-1995

Unit μ V

Temperature (°C)	0	1	2	3	4	5	6	7	8	9	Temperature (°C)
400	3408	3418	3428	3439	3449	3460	3470	3480	3491	3501	400
410	3512	3522	3533	3543	3553	3564	3574	3585	3595	3606	410
420	3616	3627	3637	3648	3658	3669	3679	3690	3700	3711	420
430	3721	3732	3742	3753	3764	3774	3785	3795	3806	3816	430
440	3827	3838	3848	3859	3869	3880	3891	3901	3912	3922	440
450	3933	3944	3954	3965	3976	3986	3997	4008	4018	4029	450
460	4040	4050	4061	4072	4083	4093	4104	4115	4125	4136	460
470	4147	4158	4168	4179	4190	4201	4211	4222	4233	4244	470
480	4255	4265	4276	4287	4298	4309	4319	4330	4341	4352	480
490	4363	4373	4384	4395	4406	4417	4428	4439	4449	4460	490
500	4471	4482	4493	4504	4515	4526	4537	4548	4558	4569	500
510	4580	4591	4602	4613	4624	4635	4646	4657	4668	4679	510
520	4690	4701	4712	4723	4734	4745	4756	4767	4778	4789	520
530	4800	4811	4822	4833	4844	4855	4866	4877	4888	4899	530
540	4910	4922	4933	4944	4955	4966	4977	4988	4999	5010	540
550	5021	5033	5044	5055	5066	5077	5088	5099	5111	5122	550
560	5133	5144	5155	5166	5178	5189	5200	5211	5222	5234	560
570	5245	5256	5267	5279	5290	5301	5312	5323	5335	5346	570
580	5357	5369	5380	5391	5402	5414	5425	5436	5448	5459	580
590	5470	5481	5493	5504	5515	5527	5538	5549	5561	5572	590
600	5583	5595	5606	5618	5629	5640	5652	5663	5674	5686	600
610	5697	5709	5720	5731	5743	5754	5766	5777	5789	5800	610
620	5812	5823	5834	5846	5857	5869	5880	5892	5903	5915	620
630	5926	5938	5949	5961	5972	5984	5995	6007	6018	6030	630
640	6041	6053	6065	6076	6088	6099	6111	6122	6134	6146	640
650	6157	6169	6180	6192	6204	6215	6227	6238	6250	6262	650
660	6273	6285	6297	6308	6320	6332	6343	6355	6367	6378	660
670	6390	6402	6413	6425	6437	6448	6460	6472	6484	6495	670
680	6507	6519	6531	6542	6554	6566	6578	6589	6601	6613	680
690	6625	6636	6648	6660	6672	6684	6695	6707	6719	6731	690
700	6743	6755	6766	6778	6790	6802	6814	6826	6838	6849	700
710	6861	6873	6885	6897	6909	6921	6933	6945	6956	6968	710
720	6980	6992	7004	7016	7028	7040	7052	7064	7076	7088	720
730	7100	7112	7124	7136	7148	7160	7172	7184	7196	7208	730
740	7220	7232	7244	7256	7268	7280	7292	7304	7316	7328	740
750	7340	7352	7364	7376	7389	7401	7413	7425	7437	7449	750
760	7461	7473	7485	7498	7510	7522	7534	7546	7558	7570	760
770	7583	7595	7607	7619	7631	7644	7656	7668	7680	7692	770
780	7705	7717	7729	7741	7753	7766	7778	7790	7802	7815	780
790	7827	7839	7851	7864	7876	7888	7901	7913	7925	7938	790
800	7950	7962	7974	7987	7999	8011	8024	8036	8048	8061	800
810	8073	8086	8098	8110	8123	8135	8147	8160	8172	8185	810
820	8197	8209	8222	8234	8247	8259	8272	8284	8296	8309	820
830	8321	8334	8346	8359	8371	8384	8396	8409	8421	8434	830
840	8446	8459	8471	8484	8496	8509	8521	8534	8546	8559	840
850	8571	8584	8597	8609	8622	8634	8647	8659	8672	8685	850
860	8697	8710	8722	8735	8748	8760	8773	8785	8798	8811	860
870	8823	8836	8849	8861	8874	8887	8899	8912	8925	8937	870
880	8950	8963	8975	8988	9001	9014	9026	9039	9052	9065	880
890	9077	9090	9103	9115	9128	9141	9154	9167	9179	9192	890

Type R

 Unit μ V

Conform to IEC584-1(1977), IEC584-2(1982), JIS C1602-1995

Temperature (°C)	0	1	2	3	4	5	6	7	8	9	Temperature (°C)
900	9205	9218	9230	9243	9256	9269	9282	9294	9307	9320	900
910	9333	9346	9359	9371	9384	9397	9410	9423	9436	9449	910
920	9461	9474	9487	9500	9513	9526	9539	9552	9565	9578	920
930	9590	9603	9616	9629	9642	9655	9668	9681	9694	9707	930
940	9720	9733	9746	9759	9772	9785	9798	9811	9824	9837	940
950	9850	9863	9876	9889	9902	9915	9928	9941	9954	9967	950
960	9980	9993	10006	10019	10032	10046	10059	10072	10085	10098	960
970	10111	10124	10137	10150	10163	10177	10190	10203	10216	10229	970
980	10242	10255	10268	10282	10295	10308	10321	10334	10347	10361	980
990	10374	10387	10400	10413	10427	10440	10453	10466	10480	10493	990
1000	10506	10519	10532	10546	10559	10572	10585	10599	10612	10625	1000
1010	10638	10652	10665	10678	10692	10705	10718	10731	10745	10758	1010
1020	10771	10785	10798	10811	10825	10838	10851	10865	10878	10891	1020
1030	10905	10918	10932	10945	10958	10972	10985	10998	11012	11025	1030
1040	11039	11052	11065	11079	11092	11106	11119	11132	11146	11159	1040
1050	11173	11186	11200	11213	11227	11240	11253	11267	11280	11294	1050
1060	11307	11321	11334	11348	11361	11375	11388	11402	11415	11429	1060
1070	11442	11456	11469	11483	11496	11510	11524	11537	11551	11564	1070
1080	11578	11591	11605	11618	11632	11646	11659	11673	11686	11700	1080
1090	11714	11727	11741	11754	11768	11782	11795	11809	11822	11836	1090
1100	11850	11863	11877	11891	11904	11918	11931	11945	11959	11972	1100
1110	11986	12000	12013	12027	12041	12054	12068	12082	12096	12109	1110
1120	12123	12137	12150	12164	12178	12191	12205	12219	12233	12246	1120
1130	12260	12274	12288	12301	12315	12329	12342	12356	12370	12384	1130
1140	12397	12411	12425	12439	12453	12466	12480	12494	12508	12521	1140
1150	12535	12549	12563	12577	12590	12604	12618	12632	12646	12659	1150
1160	12673	12687	12701	12715	12729	12742	12756	12770	12784	12798	1160
1170	12812	12825	12839	12853	12867	12881	12895	12909	12922	12936	1170
1180	12950	12964	12978	12992	13006	13019	13033	13047	13061	13075	1180
1190	13089	13103	13117	13131	13145	13158	13172	13186	13200	13214	1190
1200	13228	13242	13256	13270	13284	13298	13311	13325	13339	13353	1200
1210	13367	13381	13395	13409	13423	13437	13451	13465	13479	13493	1210
1220	13507	13521	13535	13549	13563	13577	13590	13604	13618	13632	1220
1230	13646	13660	13674	13688	13702	13716	13730	13744	13758	13772	1230
1240	13786	13800	13814	13828	13842	13856	13870	13884	13898	13912	1240
1250	13926	13940	13954	13968	13982	13996	14010	14024	14038	14052	1250
1260	14066	14081	14095	14109	14123	14137	14151	14165	14179	14193	1260
1270	14207	14221	14235	14249	14263	14277	14291	14305	14319	14333	1270
1280	14347	14361	14375	14390	14404	14418	14432	14446	14460	14474	1280
1290	14488	14502	14516	14530	14544	14558	14572	14586	14601	14615	1290
1300	14629	14643	14657	14671	14685	14699	14713	14727	14741	14755	1300
1310	14770	14784	14798	14812	14826	14840	14854	14868	14882	14896	1310
1320	14911	14925	14939	14953	14967	14981	14995	15009	15023	15037	1320
1330	15052	15066	15080	15094	15108	15122	15136	15150	15164	15179	1330
1340	15193	15207	15221	15235	15249	15263	15277	15291	15306	15320	1340
1350	15334	15348	15362	15376	15390	15404	15419	15433	15447	15461	1350
1360	15475	15489	15503	15517	15531	15546	15560	15574	15588	15602	1360
1370	15616	15630	15645	15659	15673	15687	15701	15715	15729	15743	1370
1380	15758	15772	15786	15800	15814	15828	15842	15856	15871	15885	1380
1390	15899	15913	15927	15941	15955	15969	15984	15998	16012	16026	1390

Type R

Conform to IEC584-1(1977), IEC584-2(1982), JIS C1602-1995

Unit μV

Temperature (°C)	0	1	2	3	4	5	6	7	8	9	Temperature (°C)
1400	16040	16054	16068	16082	16097	16111	16125	16139	16153	16167	1400
1410	16181	16196	16210	16224	16238	16252	16266	16280	16294	16309	1410
1420	16323	16337	16351	16365	16379	16393	16407	16422	16436	16450	1420
1430	16464	16478	16492	16506	16520	16534	16549	16563	16577	16591	1430
1440	16605	16619	16633	16647	16662	16676	16690	16704	16718	16732	1440
1450	16746	16760	16774	16789	16803	16817	16831	16845	16859	16873	1450
1460	16887	16901	16915	16930	16944	16958	16972	16986	17000	17014	1460
1470	17028	17042	17056	17071	17085	17099	17113	17127	17141	17155	1470
1480	17169	17183	17197	17211	17225	17240	17254	17268	17282	17296	1480
1490	17310	17324	17338	17352	17366	17380	17394	17408	17423	17437	1490
1500	17451	17465	17479	17493	17507	17521	17535	17549	17563	17577	1500
1510	17591	17605	17619	17633	17647	17661	17676	17690	17704	17718	1510
1520	17732	17746	17760	17774	17788	17802	17816	17830	17844	17858	1520
1530	17872	17886	17900	17914	17928	17942	17956	17970	17984	17998	1530
1540	18012	18026	18040	18054	18068	18082	18096	18110	18124	18138	1540
1550	18152	18166	18180	18194	18208	18222	18236	18250	18264	18278	1550
1560	18292	18306	18320	18334	18348	18362	18376	18390	18404	18417	1560
1570	18431	18445	18459	18473	18487	18501	18515	18529	18543	18557	1570
1580	18571	18585	18599	18613	18627	18640	18654	18668	18682	18696	1580
1590	18710	18724	18738	18752	18766	18779	18793	18807	18821	18835	1590
1600	18849	18863	18877	18891	18904	18918	18932	18946	18960	18974	1600
1610	18988	19002	19015	19029	19043	19057	19071	19085	19098	19112	1610
1620	19126	19140	19154	19168	19181	19195	19209	19223	19237	19250	1620
1630	19264	19278	19292	19306	19319	19333	19347	19361	19375	19388	1630
1640	19402	19416	19430	19444	19457	19471	19485	19499	19512	19526	1640
1650	19540	19554	19567	19581	19595	19609	19622	19636	19650	19663	1650
1660	19677	19691	19705	19718	19732	19746	19759	19773	19787	19800	1660
1670	19814	19828	19841	19855	19869	19882	19896	19910	19923	19937	1670
1680	19951	19964	19978	19992	20005	20019	20032	20046	20060	20073	1680
1690	20087	20100	20114	20127	20141	20154	20168	20181	20195	20208	1690
1700	20222	20235	20249	20262	20275	20289	20302	20316	20329	20342	1700
1710	20356	20369	20382	20396	20409	20422	20436	20449	20462	20475	1710
1720	20488	20502	20515	20528	20541	20554	20567	20581	20594	20607	1720
1730	20620	20633	20646	20659	20672	20685	20698	20711	20724	20736	1730
1740	20749	20762	20775	20788	20801	20813	20826	20839	20852	20864	1740
1750	20877	20890	20902	20915	20928	20940	20953	20965	20978	20990	1750
1760	21003	21015	21027	21040	21052	21065	21077	21089	21101		1760

REMARK

Standard contact temperature is 0°C.

Appendix 4.7 Standard Thermal Electromotive Force of S

Type S

Conform to IEC584-1(1977), IEC584-2(1982), JIS C1602-1995

Unit μV

Temperature (°C)	0	-1	-2	-3	-4	-5	-6	-7	-8	-9	Temperature (°C)
-50	-236										-50
-40	-194	-199	-203	-207	-211	-215	-219	-224	-228	-232	-40
-30	-150	-155	-159	-164	-168	-173	-177	-181	-186	-190	-30
-20	-103	-108	-113	-117	-122	-127	-132	-136	-141	-146	-20
-10	-53	-58	-63	-68	-73	-78	-83	-88	-93	-98	-10
0	0	-5	-11	-16	-21	-27	-32	-37	-42	-48	0
Temperature (°C)	0	1	2	3	4	5	6	7	8	9	Temperature (°C)
0	0	5	11	16	22	27	33	38	44	50	0
10	55	61	67	72	78	84	90	95	101	107	10
20	113	119	125	131	137	143	149	155	161	167	20
30	173	179	185	191	197	204	210	216	222	229	30
40	235	241	248	254	260	267	273	280	286	292	40
50	299	305	312	319	325	332	338	345	352	358	50
60	365	372	378	385	392	399	405	412	419	426	60
70	433	440	446	453	460	467	474	481	488	495	70
80	502	509	516	523	530	538	545	552	559	566	80
90	573	580	588	595	602	609	617	624	631	639	90
100	646	653	661	668	675	683	690	698	705	713	100
110	720	727	735	743	750	758	765	773	780	788	110
120	795	803	811	818	826	834	841	849	857	865	120
130	872	880	888	896	903	911	919	927	935	942	130
140	950	958	966	974	982	990	998	1006	1013	1021	140
150	1029	1037	1045	1053	1061	1069	1077	1085	1094	1102	150
160	1110	1118	1126	1134	1142	1150	1158	1167	1175	1183	160
170	1191	1199	1207	1216	1224	1232	1240	1249	1257	1265	170
180	1273	1282	1290	1298	1307	1315	1323	1332	1340	1348	180
190	1357	1365	1373	1382	1390	1399	1407	1415	1424	1432	190
200	1441	1449	1458	1466	1475	1483	1492	1500	1509	1517	200
210	1526	1534	1543	1551	1560	1569	1577	1586	1594	1603	210
220	1612	1620	1629	1638	1646	1655	1663	1672	1681	1690	220
230	1698	1707	1716	1724	1733	1742	1751	1759	1768	1777	230
240	1786	1794	1803	1812	1821	1829	1838	1847	1856	1865	240
250	1874	1882	1891	1900	1909	1918	1927	1936	1944	1953	250
260	1962	1971	1980	1989	1998	2007	2016	2025	2034	2043	260
270	2052	2061	2070	2078	2087	2096	2105	2114	2123	2132	270
280	2141	2151	2160	2169	2178	2187	2196	2205	2214	2223	280
290	2232	2241	2250	2259	2268	2277	2287	2296	2305	2314	290
300	2323	2332	2341	2350	2360	2369	2378	2387	2396	2405	300
310	2415	2424	2433	2442	2451	2461	2470	2479	2488	2497	310
320	2507	2516	2525	2534	2544	2553	2562	2571	2581	2590	320
330	2599	2609	2618	2627	2636	2646	2655	2664	2674	2683	330
340	2692	2702	2711	2720	2730	2739	2748	2758	2767	2776	340
350	2786	2795	2805	2814	2823	2833	2842	2851	2861	2870	350
360	2880	2889	2899	2908	2917	2927	2936	2946	2955	2965	360
370	2974	2983	2993	3002	3012	3021	3031	3040	3050	3059	370
380	3069	3078	3088	3097	3107	3116	3126	3135	3145	3154	380
390	3164	3173	3183	3192	3202	3212	3221	3231	3240	3250	390

Type S

Conform to IEC584-1(1977), IEC584-2(1982), JIS C1602-1995

Unit μV

Temperature (°C)	0	1	2	3	4	5	6	7	8	9	Temperature (°C)
400	3259	3269	3279	3288	3298	3307	3317	3326	3336	3346	400
410	3355	3365	3374	3384	3394	3403	3413	3423	3432	3442	410
420	3451	3461	3471	3480	3490	3500	3509	3519	3529	3538	420
430	3548	3558	3567	3577	3587	3596	3606	3616	3626	3635	430
440	3645	3655	3664	3674	3684	3694	3703	3713	3723	3732	440
450	3742	3752	3762	3771	3781	3791	3801	3810	3820	3830	450
460	3840	3850	3859	3869	3879	3889	3898	3908	3918	3928	460
470	3938	3947	3957	3967	3977	3987	3997	4006	4016	4026	470
480	4036	4046	4056	4065	4075	4085	4095	4105	4115	4125	480
490	4134	4144	4154	4164	4174	4184	4194	4204	4213	4223	490
500	4233	4243	4253	4263	4273	4283	4293	4303	4313	4323	500
510	4332	4342	4352	4362	4372	4382	4392	4402	4412	4422	510
520	4432	4442	4452	4462	4472	4482	4492	4502	4512	4522	520
530	4532	4542	4552	4562	4572	4582	4592	4602	4612	4622	530
540	4632	4642	4652	4662	4672	4682	4692	4702	4712	4722	540
550	4732	4742	4752	4762	4772	4782	4793	4803	4813	4823	550
560	4833	4843	4853	4863	4873	4883	4893	4904	4914	4924	560
570	4934	4944	4954	4964	4974	4984	4995	5005	5015	5025	570
580	5035	5045	5055	5066	5076	5086	5096	5106	5116	5127	580
590	5137	5147	5157	5167	5178	5188	5198	5208	5218	5228	590
600	5239	5249	5259	5269	5280	5290	5300	5310	5320	5331	600
610	5341	5351	5361	5372	5382	5392	5402	5413	5423	5433	610
620	5443	5454	5464	5474	5485	5495	5505	5515	5526	5536	620
630	5546	5557	5567	5577	5588	5598	5608	5618	5629	5639	630
640	5649	5660	5670	5680	5691	5701	5712	5722	5732	5743	640
650	5753	5763	5774	5784	5794	5805	5815	5826	5836	5846	650
660	5857	5867	5878	5888	5898	5909	5919	5930	5940	5950	660
670	5961	5971	5982	5992	6003	6013	6024	6034	6044	6055	670
680	6065	6076	6086	6097	6107	6118	6128	6139	6149	6160	680
690	6170	6181	6191	6202	6212	6223	6233	6244	6254	6265	690
700	6275	6286	6296	6307	6317	6328	6338	6349	6360	6370	700
710	6381	6391	6402	6412	6423	6434	6444	6455	6465	6476	710
720	6486	6497	6508	6518	6529	6539	6550	6561	6571	6582	720
730	6593	6603	6614	6624	6635	6646	6656	6667	6678	6688	730
740	6699	6710	6720	6731	6742	6752	6763	6774	6784	6795	740
750	6806	6817	6827	6838	6849	6859	6870	6881	6892	6902	750
760	6913	6924	6934	6945	6956	6967	6977	6988	6999	7010	760
770	7020	7031	7042	7053	7064	7074	7085	7096	7107	7117	770
780	7128	7139	7150	7161	7172	7182	7193	7204	7215	7226	780
790	7236	7247	7258	7269	7280	7291	7302	7312	7323	7334	790
800	7345	7356	7367	7378	7388	7399	7410	7421	7432	7443	800
810	7454	7465	7476	7487	7497	7508	7519	7530	7541	7552	810
820	7563	7574	7585	7596	7607	7618	7629	7640	7651	7662	820
830	7673	7684	7695	7706	7717	7728	7739	7750	7761	7772	830
840	7783	7794	7805	7816	7827	7838	7849	7860	7871	7882	840
850	7893	7904	7915	7926	7937	7948	7959	7970	7981	7992	850
860	8003	8014	8026	8037	8048	8059	8070	8081	8092	8103	860
870	8114	8125	8137	8148	8159	8170	8181	8192	8203	8214	870
880	8226	8237	8248	8259	8270	8281	8293	8304	8315	8326	880
890	8337	8348	8360	8371	8382	8393	8404	8416	8427	8438	890

Type S

Conform to IEC584-1(1977), IEC584-2(1982), JIS C1602-1995

Unit μ V

Temperature (°C)	0	1	2	3	4	5	6	7	8	9	Temperature (°C)
900	8449	8460	8472	8483	8494	8505	8517	8528	8539	8550	900
910	8562	8573	8584	8595	8607	8618	8629	8640	8652	8663	910
920	8674	8685	8697	8708	8719	8731	8742	8753	8765	8776	920
930	8787	8798	8810	8821	8832	8844	8855	8866	8878	8889	930
940	8900	8912	8923	8935	8946	8957	8969	8980	8991	9003	940
950	9014	9025	9037	9048	9060	9071	9082	9094	9105	9117	950
960	9128	9139	9151	9162	9174	9185	9197	9208	9219	9231	960
970	9242	9254	9265	9277	9288	9300	9311	9323	9334	9345	970
980	9357	9368	9380	9391	9403	9414	9426	9437	9449	9460	980
990	9472	9483	9495	9506	9518	9529	9541	9552	9564	9576	990
1000	9587	9599	9610	9622	9633	9645	9656	9668	9680	9691	1000
1010	9703	9714	9726	9737	9749	9761	9772	9784	9795	9807	1010
1020	9819	9830	9842	9853	9865	9877	9888	9900	9911	9923	1020
1030	9935	9946	9958	9970	9981	9993	10005	10016	10028	10040	1030
1040	10051	10063	10075	10086	10098	10110	10121	10133	10145	10156	1040
1050	10168	10180	10191	10203	10215	10227	10238	10250	10262	10273	1050
1060	10285	10297	10309	10320	10332	10344	10356	10367	10379	10391	1060
1070	10403	10414	10426	10438	10450	10461	10473	10485	10497	10509	1070
1080	10520	10532	10544	10556	10567	10579	10591	10603	10615	10626	1080
1090	10638	10650	10662	10674	10686	10697	10709	10721	10733	10745	1090
1100	10757	10768	10780	10792	10804	10816	10828	10839	10851	10863	1100
1110	10875	10887	10899	10911	10922	10934	10946	10958	10970	10982	1110
1120	10994	11006	11017	11029	11041	11053	11065	11077	11089	11101	1120
1130	11113	11125	11136	11148	11160	11172	11184	11196	11208	11220	1130
1140	11232	11244	11256	11268	11280	11291	11303	11315	11327	11339	1140
1150	11351	11363	11375	11387	11399	11411	11423	11435	11447	11459	1150
1160	11471	11483	11495	11507	11519	11531	11542	11554	11566	11578	1160
1170	11590	11602	11614	11626	11638	11650	11662	11674	11686	11698	1170
1180	11710	11722	11734	11746	11758	11770	11782	11794	11806	11818	1180
1190	11830	11842	11854	11866	11878	11890	11902	11914	11926	11939	1190
1200	11951	11963	11975	11987	11999	12011	12023	12035	12047	12059	1200
1210	12071	12083	12095	12107	12119	12131	12143	12155	12167	12179	1210
1220	12191	12203	12216	12228	12240	12252	12264	12276	12288	12300	1220
1230	12312	12324	12336	12348	12360	12372	12384	12397	12409	12421	1230
1240	12433	12445	12457	12469	12481	12493	12505	12517	12529	12542	1240
1250	12554	12566	12578	12590	12602	12614	12626	12638	12650	12662	1250
1260	12675	12687	12699	12711	12723	12735	12747	12759	12771	12783	1260
1270	12796	12808	12820	12832	12844	12856	12868	12880	12892	12905	1270
1280	12917	12929	12941	12953	12965	12977	12989	13001	13014	13026	1280
1290	13038	13050	13062	13074	13086	13098	13111	13123	13135	13147	1290
1300	13159	13171	13183	13195	13208	13220	13232	13244	13256	13268	1300
1310	13280	13292	13305	13317	13329	13341	13353	13365	13377	13390	1310
1320	13402	13414	13426	13438	13450	13462	13474	13487	13499	13511	1320
1330	13523	13535	13547	13559	13572	13584	13596	13608	13620	13632	1330
1340	13644	13657	13669	13681	13693	13705	13717	13729	13742	13754	1340
1350	13766	13778	13790	13802	13814	13826	13839	13851	13863	13875	1350
1360	13887	13899	13911	13924	13936	13948	13960	13972	13984	13996	1360
1370	14009	14021	14033	14045	14057	14069	14081	14094	14106	14118	1370
1380	14130	14142	14154	14166	14178	14191	14203	14215	14227	14239	1380
1390	14251	14263	14276	14288	14300	14312	14324	14336	14348	14360	1390

Type S

 Unit μ V

Conform to IEC584-1(1977), IEC584-2(1982), JIS C1602-1995

Temperature (°C)	0	1	2	3	4	5	6	7	8	9	Temperature (°C)
1400	14373	14385	14397	14409	14421	14433	14445	14457	14470	14482	1400
1410	14494	14506	14518	14530	14542	14554	14567	14579	14591	14603	1410
1420	14615	14627	14639	14651	14664	14676	14688	14700	14712	14724	1420
1430	14736	14748	14760	14773	14785	14797	14809	14821	14833	14845	1430
1440	14857	14869	14881	14894	14906	14918	14930	14942	14954	14966	1440
1450	14978	14990	15002	15015	15027	15039	15051	15063	15075	15087	1450
1460	15099	15111	15123	15135	15148	15160	15172	15184	15196	15208	1460
1470	15220	15232	15244	15256	15268	15280	15292	15304	15317	15329	1470
1480	15341	15353	15365	15377	15389	15401	15413	15425	15437	15449	1480
1490	15461	15473	15485	15497	15509	15521	15534	15546	15558	15570	1490
1500	15582	15594	15606	15618	15630	15642	15654	15666	15678	15690	1500
1510	15702	15714	15726	15738	15750	15762	15774	15786	15798	15810	1510
1520	15822	15834	15846	15858	15870	15882	15894	15906	15918	15930	1520
1530	15942	15954	15966	15978	15990	16002	16014	16026	16038	16050	1530
1540	16062	16074	16086	16098	16110	16122	16134	16146	16158	16170	1540
1550	16182	16194	16205	16217	16229	16241	16253	16265	16277	16289	1550
1560	16301	16313	16325	16337	16349	16361	16373	16385	16396	16408	1560
1570	16420	16432	16444	16456	16468	16480	16492	16504	16516	16527	1570
1580	16539	16551	16563	16575	16587	16599	16611	16623	16634	16646	1580
1590	16658	16670	16682	16694	16706	16718	16729	16741	16753	16765	1590
1600	16777	16789	16801	16812	16824	16836	16848	16860	16872	16883	1600
1610	16895	16907	16919	16931	16943	16954	16966	16978	16990	17002	1610
1620	17013	17025	17037	17049	17061	17072	17084	17096	17108	17120	1620
1630	17131	17143	17155	17167	17178	17190	17202	17214	17225	17237	1630
1640	17249	17261	17272	17284	17296	17308	17319	17331	17343	17355	1640
1650	17366	17378	17390	17401	17413	17425	17437	17448	17460	17472	1650
1660	17483	17495	17507	17518	17530	17542	17553	17565	17577	17588	1660
1670	17600	17612	17623	17635	17647	17658	17670	17682	17693	17705	1670
1680	17717	17728	17740	17751	17763	17775	17786	17798	17809	17821	1680
1690	17832	17844	17855	17867	17878	17890	17901	17913	17924	17936	1690
1700	17947	17959	17970	17982	17993	18004	18016	18027	18039	18050	1700
1710	18061	18073	18084	18095	18107	18118	18129	18140	18152	18163	1710
1720	18174	18185	18196	18208	18219	18230	18241	18252	18263	18274	1720
1730	18285	18297	18308	18319	18330	18341	18352	18362	18373	18384	1730
1740	18395	18406	18417	18428	18439	18449	18460	18471	18482	18493	1740
1750	18503	18514	18525	18535	18546	18557	18567	18578	18588	18599	1750
1760	18609	18620	18630	18641	18651	18661	18672	18682	18693	18703	1760

REMARK

Standard contact temperature is 0°C.

Appendix 4.8 Standard Thermal Electromotive Force of N

Type N

 Unit μV

Conform to IEC584-1(1977), IEC584-2(1982), JIS C1602-1995

Temperature (°C)	0	-1	-2	-3	-4	-5	-6	-7	-8	-9	Temperature (°C)
-270	-4345										-270
-260	-4336	-4337	-4339	-4340	-4341	-4342	-4343	-4344	-4344	-4345	-260
-250	-4313	-4316	-4319	-4321	-4324	-4326	-4328	-4330	-4332	-4334	-250
-240	-4277	-4281	-4285	-4289	-4293	-4297	-4300	-4304	-4307	-4310	-240
-230	-4226	-4232	-4238	-4243	-4248	-4254	-4258	-4263	-4268	-4273	-230
-220	-4162	-4169	-4176	-4183	-4189	-4196	-4202	-4209	-4215	-4221	-220
-210	-4083	-4091	-4100	-4108	-4116	-4124	-4132	-4140	-4147	-4154	-210
-200	-3990	-4000	-4010	-4020	-4029	-4038	-4048	-4057	-4066	-4074	-200
-190	-3884	-3896	-3907	-3918	-3928	-3939	-3950	-3960	-3970	-3980	-190
-180	-3766	-3778	-3790	-3803	-3815	-3827	-3838	-3850	-3862	-3873	-180
-170	-3634	-3648	-3662	-3675	-3688	-3702	-3715	-3728	-3740	-3753	-170
-160	-3491	-3506	-3521	-3535	-3550	-3564	-3578	-3593	-3607	-3621	-160
-150	-3336	-3352	-3368	-3384	-3400	-3415	-3431	-3446	-3461	-3476	-150
-140	-3171	-3188	-3205	-3221	-3238	-3255	-3271	-3288	-3304	-3320	-140
-130	-2994	-3012	-3030	-3048	-3066	-3084	-3101	-3119	-3136	-3153	-130
-120	-2808	-2827	-2846	-2865	-2883	-2902	-2921	-2939	-2958	-2976	-120
-110	-2612	-2632	-2652	-2672	-2691	-2711	-2730	-2750	-2769	-2789	-110
-100	-2407	-2428	-2448	-2469	-2490	-2510	-2531	-2551	-2571	-2592	-100
-90	-2193	-2215	-2237	-2258	-2280	-2301	-2322	-2344	-2365	-2386	-90
-80	-1972	-1995	-2017	-2039	-2062	-2084	-2106	-2128	-2150	-2172	-80
-70	-1744	-1767	-1790	-1813	-1836	-1859	-1882	-1905	-1927	-1950	-70
-60	-1509	-1533	-1557	-1580	-1604	-1627	-1651	-1674	-1698	-1721	-60
-50	-1269	-1293	-1317	-1341	-1366	-1390	-1414	-1438	-1462	-1485	-50
-40	-1023	-1048	-1072	-1097	-1122	-1146	-1171	-1195	-1220	-1244	-40
-30	-772	-798	-823	-848	-873	-898	-923	-948	-973	-998	-30
-20	-518	-544	-569	-595	-620	-646	-671	-696	-722	-747	-20
-10	-260	-286	-312	-338	-364	-390	-415	-441	-467	-492	-10
0	0	-26	-52	-78	-104	-131	-157	-183	-209	-234	0
Temperature (°C)	0	1	2	3	4	5	6	7	8	9	Temperature (°C)
0	0	26	52	78	104	130	156	182	208	235	0
10	261	287	313	340	366	393	419	446	472	499	10
20	525	552	578	605	632	659	685	712	739	766	20
30	793	820	847	874	901	928	955	983	1010	1037	30
40	1065	1092	1119	1147	1174	1202	1229	1257	1284	1312	40
50	1340	1368	1395	1423	1451	1479	1507	1535	1563	1591	50
60	1619	1647	1675	1703	1732	1760	1788	1817	1845	1873	60
70	1902	1930	1959	1988	2016	2045	2074	2102	2131	2160	70
80	2189	2218	2247	2276	2305	2334	2363	2392	2421	2450	80
90	2480	2509	2538	2568	2597	2626	2656	2685	2715	2744	90
100	2774	2804	2833	2863	2893	2923	2953	2983	3012	3042	100
110	3072	3102	3133	3163	3193	3223	3253	3283	3314	3344	110
120	3374	3405	3435	3466	3496	3527	3557	3588	3619	3649	120
130	3680	3711	3742	3772	3803	3834	3865	3896	3927	3958	130
140	3989	4020	4051	4083	4114	4145	4176	4208	4239	4270	140
150	4302	4333	4365	4396	4428	4459	4491	4523	4554	4586	150
160	4618	4650	4681	4713	4745	4777	4809	4841	4873	4905	160
170	4937	4969	5001	5033	5066	5098	5130	5162	5195	5227	170
180	5259	5292	5324	5357	5389	5422	5454	5487	5520	5552	180

Type N

Conform to IEC584-1(1977), IEC584-2(1982), JIS C1602-1995

Unit μ V

Temperature (°C)	0	1	2	3	4	5	6	7	8	9	Temperature (°C)
190	5585	5618	5650	5683	5716	5749	5782	5815	5847	5880	190
200	5913	5946	5979	6013	6046	6079	6112	6145	6178	6211	200
210	6245	6278	6311	6345	6378	6411	6445	6478	6512	6545	210
220	6579	6612	6646	6680	6713	6747	6781	6814	6848	6882	220
230	6916	6949	6983	7017	7051	7085	7119	7153	7187	7221	230
240	7255	7289	7323	7357	7392	7426	7460	7494	7528	7563	240
250	7597	7631	7666	7700	7734	7769	7803	7838	7872	7907	250
260	7941	7976	8010	8045	8080	8114	8149	8184	8218	8253	260
270	8288	8323	8358	8392	8427	8462	8497	8532	8567	8602	270
280	8637	8672	8707	8742	8777	8812	8847	8882	8918	8953	280
290	8988	9023	9058	9094	9129	9164	9200	9235	9270	9306	290
300	9341	9377	9412	9448	9483	9519	9554	9590	9625	9661	300
310	9696	9732	9768	9803	9839	9875	9910	9946	9982	10018	310
320	10054	10089	10125	10161	10197	10233	10269	10305	10341	10377	320
330	10413	10449	10485	10521	10557	10593	10629	10665	10701	10737	330
340	10774	10810	10846	10882	10918	10955	10991	11027	11064	11100	340
350	11136	11173	11209	11245	11282	11318	11355	11391	11428	11464	350
360	11501	11537	11574	11610	11647	11683	11720	11757	11793	11830	360
370	11867	11903	11940	11977	12013	12050	12087	12124	12160	12197	370
380	12234	12271	12308	12345	12382	12418	12455	12492	12529	12566	380
390	12603	12640	12677	12714	12751	12788	12825	12862	12899	12937	390
400	12974	13011	13048	13085	13122	13159	13197	13234	13271	13308	400
410	13346	13383	13420	13457	13495	13532	13569	13607	13644	13682	410
420	13719	13756	13794	13831	13869	13906	13944	13981	14019	14056	420
430	14094	14131	14169	14206	14244	14281	14319	14356	14394	14432	430
440	14469	14507	14545	14582	14620	14658	14695	14733	14771	14809	440
450	14846	14884	14922	14960	14998	15035	15073	15111	15149	15187	450
460	15225	15262	15300	15338	15376	15414	15452	15490	15528	15566	460
470	15604	15642	15680	15718	15756	15794	15832	15870	15908	15946	470
480	15984	16022	16060	16099	16137	16175	16213	16251	16289	16327	480
490	16366	16404	16442	16480	16518	16557	16595	16633	16671	16710	490
500	16748	16786	16824	16863	16901	16939	16978	17016	17054	17093	500
510	17131	17169	17208	17246	17285	17323	17361	17400	17438	17477	510
520	17515	17554	17592	17630	17669	17707	17746	17784	17823	17861	520
530	17900	17938	17977	18016	18054	18093	18131	18170	18208	18247	530
540	18286	18324	18363	18401	18440	18479	18517	18556	18595	18633	540
550	18672	18711	18749	18788	18827	18865	18904	18943	18982	19020	550
560	19059	19098	19136	19175	19214	19253	19292	19330	19369	19408	560
570	19447	19485	19524	19563	19602	19641	19680	19718	19757	19796	570
580	19835	19874	19913	19952	19990	20029	20068	20107	20146	20185	580
590	20224	20263	20302	20341	20379	20418	20457	20496	20535	20574	590
600	20613	20652	20691	20730	20769	20808	20847	20886	20925	20964	600
610	21003	21042	21081	21120	21159	21198	21237	21276	21315	21354	610
620	21393	21432	21471	21510	21549	21588	21628	21667	21706	21745	620
630	21784	21823	21862	21901	21940	21979	22018	22058	22097	22136	630
640	22175	22214	22253	22292	22331	22370	22410	22449	22488	22527	640
650	22566	22605	22644	22684	22723	22762	22801	22840	22879	22919	650
660	22958	22997	23036	23075	23115	23154	23193	23232	23271	23311	660
670	23350	23389	23428	23467	23507	23546	23585	23624	23663	23703	670
680	23742	23781	23820	23860	23899	23938	23977	24016	24056	24095	680
690	24134	24173	24213	24252	24291	24330	24370	24409	24448	24487	690

Type N

Conform to IEC584-1(1977), IEC584-2(1982), JIS C1602-1995

Unit μ V

Temperature (°C)	0	1	2	3	4	5	6	7	8	9	Temperature (°C)
700	24527	24566	24605	24644	24684	24723	24762	24801	24841	24880	700
710	24919	24959	24998	25037	25076	25116	25155	25194	25233	25273	710
720	25312	25351	25391	25430	25469	25508	25548	25587	25626	25666	720
730	25705	25744	25783	25823	25862	25901	25941	25980	26019	26058	730
740	26098	26137	26176	26216	26255	26294	26333	26373	26412	26451	740
750	26491	26530	26569	26608	26648	26687	26726	26766	26805	26844	750
760	26883	26923	26962	27001	27041	27080	27119	27158	27198	27237	760
770	27276	27316	27355	27394	27433	27473	27512	27551	27591	27630	770
780	27669	27708	27748	27787	27826	27866	27905	27944	27983	28023	780
790	28062	28101	28140	28180	28219	28258	28297	28337	28376	28415	790
800	28455	28494	28533	28572	28612	28651	28690	28729	28769	28808	800
810	28847	28886	28926	28965	29004	29043	29083	29122	29161	29200	810
820	29239	29279	29318	29357	29396	29436	29475	29514	29553	29592	820
830	29632	29671	29710	29749	29789	29828	29867	29906	29945	29985	830
840	30024	30063	30102	30141	30181	30220	30259	30298	30337	30376	840
850	30416	30455	30494	30533	30572	30611	30651	30690	30729	30768	850
860	30807	30846	30886	30925	30964	31003	31042	31081	31120	31160	860
870	31199	31238	31277	31316	31355	31394	31433	31473	31512	31551	870
880	31590	31629	31668	31707	31746	31785	31824	31863	31903	31942	880
890	31981	32020	32059	32098	32137	32176	32215	32254	32293	32332	890
900	32371	32410	32449	32488	32527	32566	32605	32644	32683	32722	900
910	32761	32800	32839	32878	32917	32956	32995	33034	33073	33112	910
920	33151	33190	33229	33268	33307	33346	33385	33424	33463	33502	920
930	33541	33580	33619	33658	33697	33736	33774	33813	33852	33891	930
940	33930	33969	34008	34047	34086	34124	34163	34202	34241	34280	940
950	34319	34358	34396	34435	34474	34513	34552	34591	34629	34668	950
960	34707	34746	34785	34823	34862	34901	34940	34979	35017	35056	960
970	35095	35134	35172	35211	35250	35289	35327	35366	35405	35444	970
980	35482	35521	35560	35598	35637	35676	35714	35753	35792	35831	980
990	35869	35908	35946	35985	36024	36062	36101	36140	36178	36217	990
1000	36256	36294	36333	36371	36410	36449	36487	36526	36564	36603	1000
1010	36641	36680	36718	36757	36796	36834	36873	36911	36950	36988	1010
1020	37027	37065	37104	37142	37181	37219	37258	37296	37334	37373	1020
1030	37411	37450	37488	37527	37565	37603	37642	37680	37719	37757	1030
1040	37795	37834	37872	37911	37949	37987	38026	38064	38102	38141	1040
1050	38179	38217	38256	38294	38332	38370	38409	38447	38485	38524	1050
1060	38562	38600	38638	38677	38715	38753	38791	38829	38868	38906	1060
1070	38944	38982	39020	39059	39097	39135	39173	39211	39249	39287	1070
1080	39326	39364	39402	39440	39478	39516	39554	39592	39630	39668	1080
1090	39706	39744	39783	39821	39859	39897	39935	39973	40011	40049	1090
1100	40087	40125	40163	40201	40238	40276	40314	40352	40390	40428	1100
1110	40466	40504	40542	40580	40618	40655	40693	40731	40769	40807	1110
1120	40845	40883	40920	40958	40996	41034	41072	41109	41147	41185	1120
1130	41223	41260	41298	41336	41374	41411	41449	41487	41525	41562	1130
1140	41600	41638	41675	41713	41751	41788	41826	41864	41901	41939	1140
1150	41976	42014	42052	42089	42127	42164	42202	42239	42277	42314	1150
1160	42352	42390	42427	42465	42502	42540	42577	42614	42652	42689	1160
1170	42727	42764	42802	42839	42877	42914	42951	42989	43026	43064	1170
1180	43101	43138	43176	43213	43250	43288	43325	43362	43399	43437	1180
1190	43474	43511	43549	43586	43623	43660	43698	43735	43772	43809	1190

Type N

Conform to IEC584-1(1977), IEC584-2(1982), JIS C1602-1995

Unit μV

Temperature (°C)	0	1	2	3	4	5	6	7	8	9	Temperature (°C)
1200	43846	43884	43921	43958	43995	44032	44069	44106	44144	44181	1200
1210	44218	44255	44292	44329	44366	44403	44440	44477	44514	44551	1210
1220	44588	44625	44662	44699	44736	44773	44810	44847	44884	44921	1220
1230	44958	44995	45032	45069	45105	45142	45179	45216	45253	45290	1230
1240	45326	45363	45400	45437	45474	45510	45547	45584	45621	45657	1240
1250	45694	45731	45767	45804	45841	45877	45914	45951	45987	46024	1250
1260	46060	46097	46133	46170	46207	46243	46280	46316	46353	46389	1260
1270	46425	46462	46498	46535	46571	46608	46644	46680	46717	46753	1270
1280	46789	46826	46862	46898	46935	46971	47007	47043	47079	47116	1280
1290	47152	47188	47224	47260	47296	47333	47369	47405	47441	47477	1290
1300	47513										1300

REMARK

Standard contact temperature is 0°C.

Appendix 5 External Dimensions

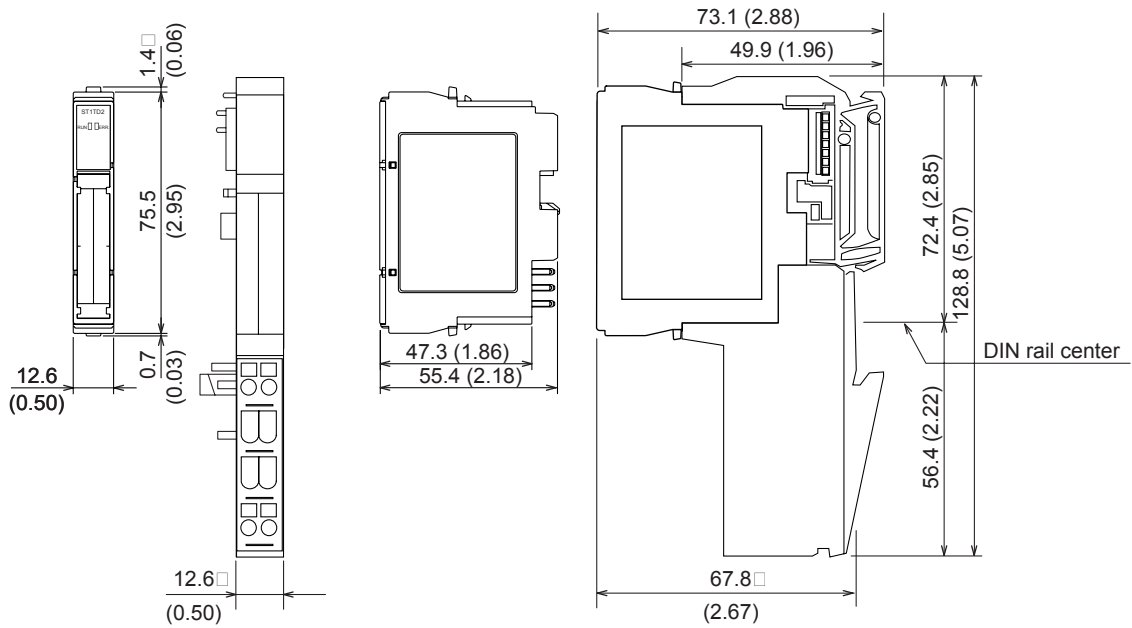

Unit: mm (inch)

REMARK

For ST1TD2 of hardware version B or before, side face diagram of the module is as follows.

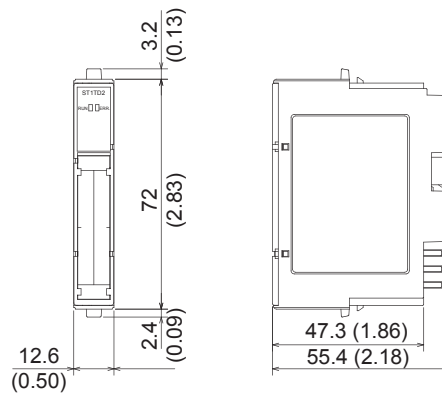

Unit: mm (inch)

INDEX

- [2]
24V DC current..... 3-1
- [A]
Accessories App-1
Accuracy 3-1, 3-3
Alarm output function 3-7, 3-14
Alarm output signal..... 3-20
Averaging process 3-12
Average time/average number of times set value write 8-28
Average time/average number of times set value read..... 8-13
- [B]
Base module..... 2-2
Bit input area 3-19
Bit output area 3-22
Br 3-19
Bw 3-22
- [C]
Coding element 2-2, 4-3, App-1
Command 3-8, 8-1
Command list..... 8-1
Command parameter 3-25
Compensation of measured temperature/micro voltage value 3-21
Conversion completed flag 3-20
Conversion completion channel read 8-9
Conversion enable/disable function..... 3-6
Conversion enable/disable setting read 8-9
Conversion enable/disable setting write 8-23
Conversion speed 3-1, 3-5
Convert setting completed flag 3-19
Convert setting request 3-22
Current consumption..... 3-1
- [D]
Data symbol..... A-10
Disconnection detection function 3-6, 3-13
- [E]
EMC directive A-9
Er 3-20
- Error clear area 3-23
Error clear request 3-23
Error code list 9-1
Error code read request..... 8-5
Error information 3-20
Error information area..... 3-20
Ew..... 3-23
External AUX. power supply..... 3-1
External dimensions App-32
External wiring..... 4-6
- [F]
Features 1-1
Forced output test..... 5-8
Function list 3-6
- [G]
Gain channel specification..... 8-43
GX Configurator-ST Functions 5-1
- [H]
Handling precautions 4-1
Head module..... 2-2
- [I]
I/O data..... 3-18
Input data A-10, A-13, 3-1, 3-18
Input type..... 3-7
Input/output monitor 5-7
Intelligent function module processing time.... 3-7
Isolation 3-1
- [L]
LED indications 4-4
Low voltage directive A-9
Lower upper/lower lower limit set value read 8-17
Lower upper/lower lower limit set value write 8-32

[M]
 Measured temperature value/micro voltage conversion value 3-21
 Memory 3-24
 Micro voltage I/O conversion characteristic ... 3-4
 Module ready 3-19
 Module status 3-21
 Module status area 3-21
 Mr 3-21

[N]
 Number of occupied I/O points 3-1
 Number of occupied slices 3-1
 Number of times averaging 3-6, 3-12

[O]
 Offset channel specification 8-41
 Offset/gain setting 4-9, 5-10
 Online module change 7-1
 Operation condition set value read 8-11
 Operation condition set value write 8-26
 Operation mode setting 8-39
 Operation status read request 8-3
 Output data A-11, A-13, 3-1, 3-18

[P]
 Parameter 3-25
 Parameter setting 5-3
 Parameter setting ROM read 8-36
 Parameter setting ROM write 8-37
 Part names 4-3
 Performance specification 3-1
 Programming 6-1
 Project creation 5-2

[R]
 RAM 3-24
 Resolution 3-1
 ROM 3-24
 ROM write count 3-1

[S]
 Sampling process 3-11
 Sensor compensation function 3-17
 Sensor compensation value read 8-22
 Sensor compensation value write 8-34
 Set up and procedure before operation 4-2
 Software package 2-2

Specification 3-1
 System configuration 2-1

[T]
 Temperature/micro voltage conversion system 3-6
 Terminal block 4-3, 4-4
 Thermocouple 3-1
 Time averaging 3-6, 3-12
 Troubleshooting 9-4

[U]
 Upper upper/upper lower set value read 8-15
 Upper upper/upper lower set value write 8-30
 User parameter 3-25
 User parameter set value read 8-19
 User range write 8-45

[V]
 Values stored into command execution result 8-46

[W]
 Weight 3-2
 Wiring 4-5
 Wiring maker App-1
 Wiring precautions 4-5
 Word input area 3-21
 Word output area 3-23
 Wr 3-21
 Ww 3-23

WARRANTY

Please confirm the following product warranty details before starting use.

1. Gratis Warranty Term and Gratis Warranty Range

If any faults or defects (hereinafter "Failure") found to be the responsibility of Mitsubishi occurs during use of the product within the gratis warranty term, the product shall be repaired at no cost via the dealer or Mitsubishi Service Company. Note that if repairs are required at a site overseas, on a detached island or remote place, expenses to dispatch an engineer shall be charged for.

[Gratis Warranty Term]

The gratis warranty term of the product shall be for one year after the date of purchase or delivery to a designated place.

Note that after manufacture and shipment from Mitsubishi, the maximum distribution period shall be six (6) months, and the longest gratis warranty term after manufacturing shall be eighteen (18) months. The gratis warranty term of repair parts shall not exceed the gratis warranty term before repairs.

[Gratis Warranty Range]

- (1) The range shall be limited to normal use within the usage state, usage methods and usage environment, etc., which follow the conditions and precautions, etc., given in the instruction manual, user's manual and caution labels on the product.
- (2) Even within the gratis warranty term, repairs shall be charged for in the following cases.
 1. Failure occurring from inappropriate storage or handling, carelessness or negligence by the user. Failure caused by the user's hardware or software design.
 2. Failure caused by unapproved modifications, etc., to the product by the user.
 3. When the Mitsubishi product is assembled into a user's device, Failure that could have been avoided if functions or structures, judged as necessary in the legal safety measures the user's device is subject to or as necessary by industry standards, had been provided.
 4. Failure that could have been avoided if consumable parts (battery, backlight, fuse, etc.) designated in the instruction manual had been correctly serviced or replaced.
 5. Failure caused by external irresistible forces such as fires or abnormal voltages, and Failure caused by force majeure such as earthquakes, lightning, wind and water damage.
 6. Failure caused by reasons unpredictable by scientific technology standards at time of shipment from Mitsubishi.
 7. Any other failure found not to be the responsibility of Mitsubishi or the user.

2. Onerous repair term after discontinuation of production

- (1) Mitsubishi shall accept onerous product repairs for seven (7) years after production of the product is discontinued. Discontinuation of production shall be notified with Mitsubishi Technical Bulletins, etc.
- (2) Product supply (including repair parts) is not possible after production is discontinued.

3. Overseas service

Overseas, repairs shall be accepted by Mitsubishi's local overseas FA Center. Note that the repair conditions at each FA Center may differ.

4. Exclusion of chance loss and secondary loss from warranty liability

Regardless of the gratis warranty term, Mitsubishi shall not be liable for compensation to damages caused by any cause found not to be the responsibility of Mitsubishi, chance losses, lost profits incurred to the user by Failures of Mitsubishi products, damages and secondary damages caused from special reasons regardless of Mitsubishi's expectations, compensation for accidents, and compensation for damages to products other than Mitsubishi products and other duties.

5. Changes in product specifications

The specifications given in the catalogs, manuals or technical documents are subject to change without prior notice.

6. Product application

- (1) In using the Mitsubishi MELSEC programmable logic controller, the usage conditions shall be that the application will not lead to a major accident even if any problem or fault should occur in the programmable logic controller device, and that backup and fail-safe functions are systematically provided outside of the device for any problem or fault.
- (2) The Mitsubishi general-purpose programmable logic controller has been designed and manufactured for applications in general industries, etc. Thus, applications in which the public could be affected such as in nuclear power plants and other power plants operated by respective power companies, and applications in which a special quality assurance system is required, such as for Railway companies or National Defense purposes shall be excluded from the programmable logic controller applications.

Note that even with these applications, if the user approves that the application is to be limited and a special quality is not required, application shall be possible.

When considering use in aircraft, medical applications, railways, incineration and fuel devices, manned transport devices, equipment for recreation and amusement, and safety devices, in which human life or assets could be greatly affected and for which a particularly high reliability is required in terms of safety and control system, please consult with Mitsubishi and discuss the required specifications.

MELSEC-ST

Thermocouple Input Module

User's Manual

MODEL	ST1TD-U-SY-E
MODEL CODE	13JR78
SH(NA)-080539ENG-B(0606)MEE	



HEAD OFFICE : TOKYO BUILDING, 2-7-3 MARUNOUCHI, CHIYODA-KU, TOKYO 100-8310, JAPAN
NAGOYA WORKS : 1-14, YADA-MINAMI 5-CHOME, HIGASHI-KU, NAGOYA, JAPAN

When exported from Japan, this manual does not require application to the Ministry of Economy, Trade and Industry for service transaction permission.

Specifications subject to change without notice.