

# OMRON

Model **ZN-KMX21-**

Power Sensor Station

## INSTRUCTION SHEET

Thank you for selecting OMRON product. This sheet primarily describes precautions required in installing and operating the product. Before operating the product, read the sheet thoroughly to acquire sufficient knowledge of the product. For your convenience, keep the sheet at your disposal.

### TRACEABILITY INFORMATION:

Importer in EU: OMRON Europe B.V.  
Wegalaan 67-69  
2132 JD Hoofddorp,  
The Netherlands

Manufacturer: OMRON Corporation,  
Shiokoji Horikawa, Shimogyo-ku,  
Kyoto 600-8530 JAPAN

The following notice applies only to products that carry the CE mark:  
Notice:  
This is a class A product. In residential areas it may cause radio interference, in which case the user may be required to take adequate measures to reduce interference.

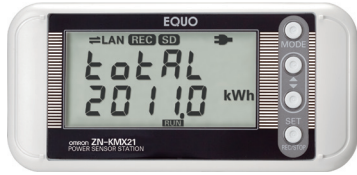

© OMRON Corporation 2011 All Rights Reserved.

### Perchlorate regulations by the State of California, USA

This product uses a lithium battery that contains perchlorate that is regulated by California State Law. Appropriate measures must be taken to comply with regulations. For details, refer to the URL as below:  
[www.dtsc.ca.gov/hazardouswaste/perchlorate](http://www.dtsc.ca.gov/hazardouswaste/perchlorate)

## PRECAUTIONS ON SAFETY

### Meanings of Signal Words

**WARNING** Indicates a potentially hazardous situation which, if not avoided, will result in minor or moderate injury, or may result in serious injury or death. Additionally there may be significant property damage.

**CAUTION** Indicates a potentially hazardous situation which, if not avoided, may result in minor or moderate injury or in property damage.

### Meaning of Precaution Symbols

|  |   |
|--|---|
|  | ● Mandatory Requirement<br>Indicates a general mandatory requirement.   |
|  | ● Prohibition<br>Indicates general prohibition.   |
|  | ● Electric Shock Warning<br>Warns against an electric shock under specific conditions.                                    |
|  | ● Explosion Warning<br>Warns against an explosion under specific conditions.  |
|  | ● Disassembly Prohibition<br>Indicates the possibility of accidents such as an electric shock caused by unit disassembly. |

### Warning Indications

|  |                |
|--|----------------|
|  | <b>WARNING</b> |
| The mounting magnets provided with the product have strong magnetism. If the product is mounted using these magnets, anyone wearing a heart pacemaker must not operate the product; or the product must not be in proximity of such a person.  |                |
| This product contains lithium batteries. Serious injury may occur due to fire or explosion. Do not attempt to disassemble the product, deform it by applying pressure, heat it in a high temperature (100°C or more), or burn it for disposal. |                |

|  |                |
|--|----------------|
|  | <b>CAUTION</b> |
| Tighten the terminal screws at a recommended torque: 0.69 to 0.88N·m. Make sure that the screws are not slanted away from the center after tightened.          |                |
| A minor or moderate injury or property damage may occur due to explosion. Do not use the product in an environment containing an inflammable or explosive gas. |                |
| An electric shock may occur. Do not replace the batteries when the unit is clamped to a conductor for measurement.   |                |

## PRECAUTIONS FOR SAFE USE

Observe the following precautions to ensure safe operation.

- Do not install the product in the places subject to exposure to water, oil, or chemical splashes.
  - Only the provided AC adapter (not other) must be used when using AC power supply.
  - If a voltage that exceeds the rated voltage is applied to the AC adapter, smoking may occur. Do not connect a power supply that exceeds the rated voltage. In a situation where a voltage higher than the rating is applied, use protective equipment so that the power supply voltage does not exceed the rated voltage.
  - Dispose of the product as industrial waste.
  - Do not let the product drop or subject it to a shock, which may cause its damage or malfunction. Use screws to secure the product when mounting it on the wall. Stop using the product if it has been applied with a strong impact.
  - When inserting or removing an SD card, securely hold the product to prevent it from dropping, which may cause a damage. Do the same when inserting or detaching an AC adapter, alarm output cable, or sensor connector.
  - Do not bring the product close to magnetic products (e.g. magnetic cards), sensitive electronics equipment (e.g. computers or clocks), when the product is attached with the mounting magnets.
  - Small pieces may be chipped off the mounting magnets when they are attracted to the surface. Make sure the pieces do not enter the eyes. Consult a medical doctor if this happens.
  - When using the mounting magnets to install the product, take caution not to allow a finger to be caught between the product(s) and the magnetic surface.
  - Do not install the product at a high place when using the mounting magnets.
  - Apply an appropriate load to the alarm output terminals to prevent possible smoking.
  - If liquid crystal leaks due to a damage to the LCD panel, take caution not to allow it to contact your skin, to be inhaled or swallowed. If it has contacted your skin or entered your mouth, seek medical attention.
  - Take anti-static electricity measures (e.g. touching grounded metal object) when handling the product.
- Applicable standards
- EN61326-1
  - Electromagnetic environment : Industrial electromagnetic environment (EN/IEC 61326-1 Table 2)

## PRECAUTIONS FOR CORRECT USE

1. Avoid installing the product in the following places:

- Places exceeding the rated ambient temperature
- Places exposed to extreme temperature changes (where condensation occurs)
- Places subject to relative humidity exceeding the rated humidity range
- Places subject to corrosive or flammable gases
- Places subject to mist, droplets, coarse particles, fiber, salt, metal dust, or large amount of particles
- Places subject to direct shock or vibration
- Places subject to direct sunlight
- Places subject to exposure to water, oil, or chemical splashes
- Places subject to strong magnetic field or electric field
- Outdoors

2. Wiring

- Wire the product cable separately from high-voltage or power lines. Placing them in the same wiring or the same duct may cause induction, resulting in the product malfunction or damage.
- Make sure that the I/O terminals are inserted or removed with the power turned OFF. Doing this with the power ON may result in a failure.
- When using a DC cable, connect the white-lined wire of the cable to the power input (24 VDC ± 3%) and the non-lined wire to 0V.

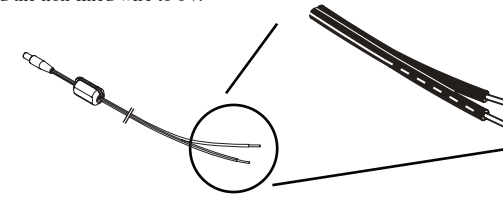

- Use a ferrite core to reduce the noise to/from other device when supplying power to the unit via a DC cable. To use the provided DC cable, attach the provided ferrite core as shown below.

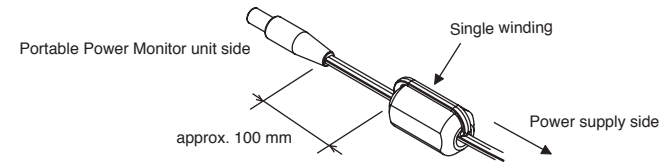

## Dimensions

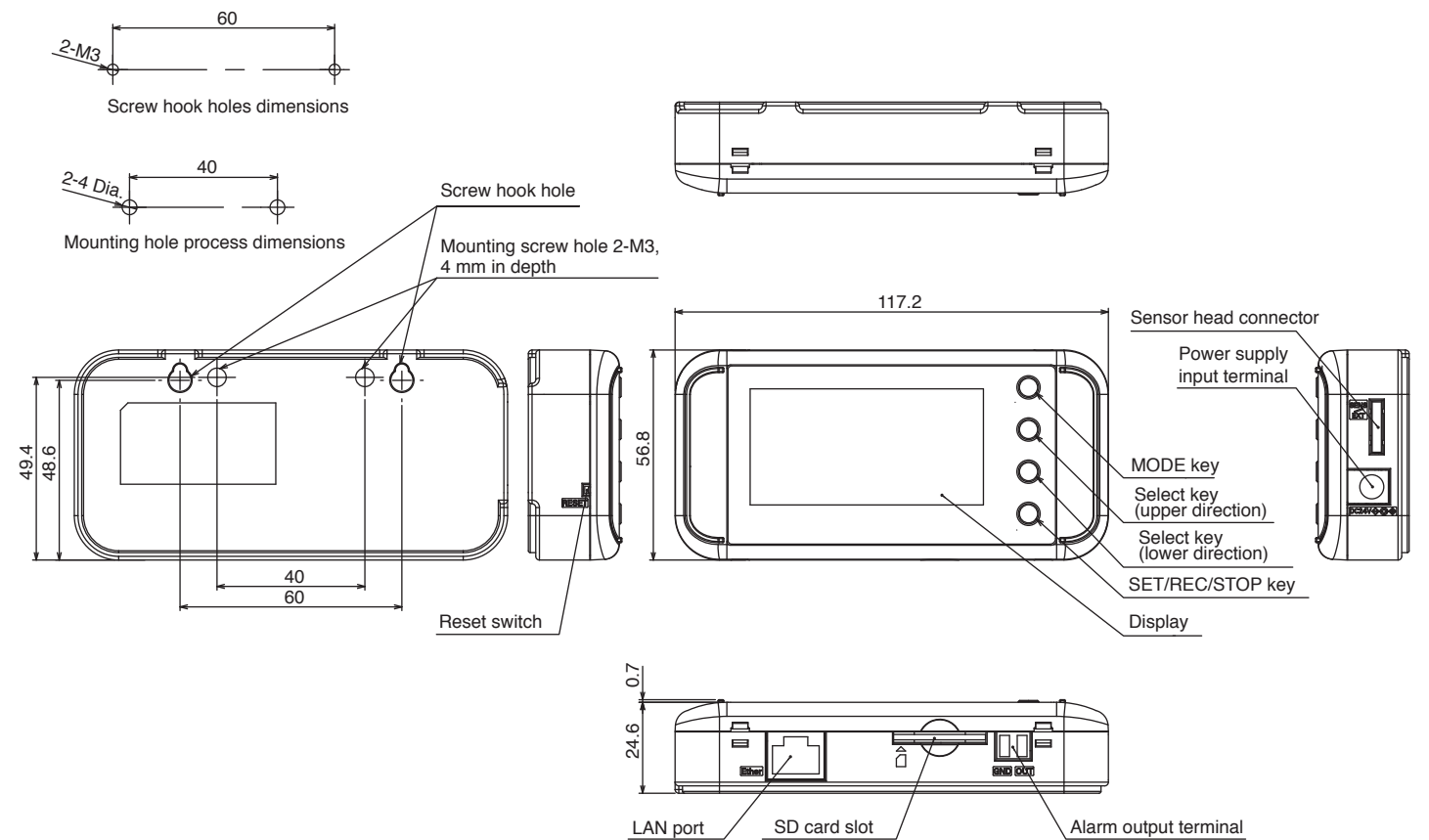

(Unit: mm)

## Overview and Features

By connecting the power monitor/sensor KM series (sold separately), the ZN-KMX21-□ allows you to record the measured data of the power monitor/sensor (KM series) and set various operations.

### ● Display and judgment output

The display of the measured data can be switched with the ▲ and ▼ keys. Also, you can select the measurement target of the monitoring target and set the threshold value to output an alarm from the output terminal.

### ● Data output and viewing

Measurement values can be recorded to the unit's memory and the recorded measurement values can be stored into the SD card.

SD card (\*): Data is in CSV format.

By using the provided software, the measured values recorded with multiple sensors can be converted into graphs and unified into one file.

\* The operation has been checked with the HMC-SD291 2GB SD card (Separately sold).

## Names and Functions

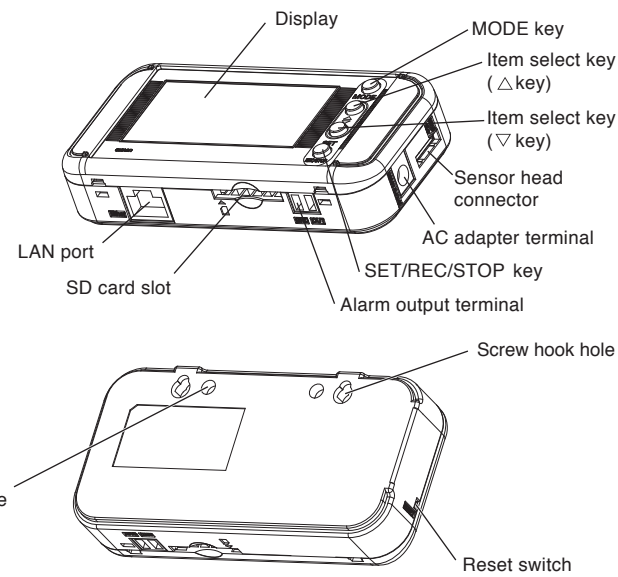

| Name                    | Function  |
|-------------------------|---|
| MODE key                | Switches operating modes<br>Releases error and alarm (holding)<br>Cancels during settings   |
| Item select key (Δ key) | Moves setting items (upper direction)<br>Switches display screens (reverse direction)<br>Changes the setting value (increasing)         |
| Item select key (▽ key) | Moves the setting items (lower direction)<br>Switches the display screens (forward direction)<br>Changes the setting value (decreasing) |
| SET/REC/STOP key        | Confirms the setting value<br>Starts/stops record (holding)<br>Saves recorded data to the SD memory card.                               |
| Mounting screw hole     | Used to secure screws (M3x4 mm female hole)   |
| Screw hook hole         | For screw head hook   |
| Reset switch            | Restarts the unit.*   |

\* Used when an SD card is not available when recording stops, or when error recovery cannot be made.

## Alarm Output Specifications

### ● Terminals

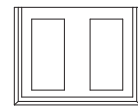

GND OUT

Terminal names are inscribed on the unit.  
For wire used for a terminal block, consider the following.  
Wire length : 30m and less  
(1) OUT  
Judgment result allocated in THR mode is output.  
(2) GND  
Common terminal.

### ● Output Specifications

Do not directly connect the external power supply between OUT and GND.  
Be sure to connect the load.

|                               |                   |
|-------------------------------|-------------------|
| External power supply voltage | 12 to 24 VDC ±10% |
| Load current                  | 45 mA max.        |
| ON residual voltage           | 1.2 V max.        |
| OFF leakage current           | 0.1 mA max.       |
| Internal circuit diagram      |                   |

## Display Unit

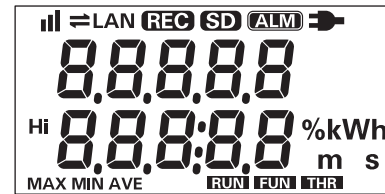

| Display    | Meaning and operation when turned on   |
|------------|--|
|            | Integral power consumption reset interval is set. The setting is OFF when it is not displayed.   |
|            | Communication with LAN cable.  |
|            | LAN cable is connected and network communication is possible.<br>Recording data into the internal memory.<br>Recording start wait using timer when blinking. |
|            | SD card has been inserted.<br>SD card is being accessed while light blinking.  |
|            | A total integrated power consumption has exceeded the specified upper threshold value.   |
|            | Power is supplied.   |
| <b>Hi</b>  | Indicates the upper limit threshold value.   |
| <b>MAX</b> | Indicates the maximum total momentary power value.   |
| <b>MIN</b> | Indicates the minimum total momentary power value.   |
| <b>AVE</b> | Indicates the average total momentary power value.   |
| <b>RUN</b> | The unit is currently operating in RUN mode.   |
| <b>FUN</b> | The unit is currently operating in FUN mode.   |
| <b>THR</b> | The unit is currently operating in THR mode.   |

## 7-segment Display List

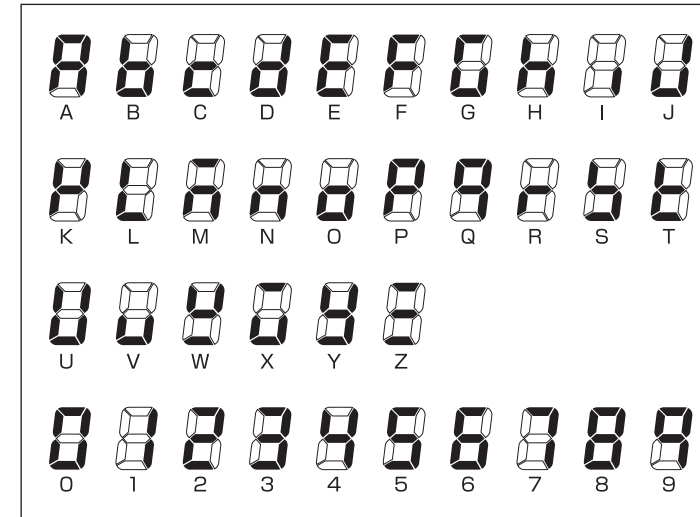

## Ratings

| Model   | ZN-KMX21-□  |
|---|---|
| Item  |   |
| Connectable Power Sensor/Monitor                      | KM20-B40-FLK, KM50-C, KM50-E, KM100   |
| Max. Number of Connectable Power Sensor/Monitor Units | 31 units  |
| Display   | 7-seg. 5-digit 2-step LCD display, auxiliary information indicator displays   |
| Recording Interval                                    | 1 s, 2 s, 5 s, 10 s, 20 s, 30 s, 1 min.   |
| Recorded data   | Momentary power, Integrated power, Power factor, Sum of pulse input counts 1 and 2 *1   |
| Operation Function                                    | Integrated power total sum, integrated momentary power, electricity rate total sum  |
| Recording Mode  | Continue mode*2, Ring mode *3   |
| External Output                                       | Alarm output (Photocoupler output) *4   |
| Communication Interface                               | Ethernet (10BASE-T, 100BASE-TX)   |
| Memory Capacity (Internal)                            | Internal memory: approx. 200 data items (at maximum load); approx. 6800 data items*5 (at minimum load)  |
| Memory Capacity (External)                            | SD card with SDHC compatibility (Save measured values, save and read setting values)  |
| Power Supply  | DC input: 24 VDC±10%, AC adapter: 100 to 240 VAC/50 to 60 Hz  |
| Current Consumption                                   | 80 mA max. (at 24 VDC); 70 mA max. (AC adapter used)  |
| Operating Temperature                                 | Without Ethernet: -10°C to 40°C (no condensation or icing) With Ethernet: 0°C to 40°C (no condensation or icing)  |
| Operating Humidity                                    | 20 to 85%RH (no condensation or icing)  |
| Storage Humidity/Temperature                          | -15°C to +60°C, 20 to 85%RH (no condensation or icing)  |
| Insulation Resistance                                 | 20 MΩ (500 VDC)   |
| Withstand Voltage                                     | 1000 VAC, 50/60 Hz, 1 min.  |
| Vibration Resistance                                  | 10 to 150 Hz, 0.7 mm double amplitude, acceleration: 50 m/s <sup>2</sup> for each in X, Y and Z directions for 80 min*6   |
| Shock Resistance                                      | 150 m/s <sup>2</sup> in 6 directions (+/-X, +/-Y, and +/-Z directions), 3 times each*6  |
| Material  | ABS   |
| Degree of Protection                                  | IP30  |
| Mounting  | Magnet mounting, screw mounting, hook, free standing  |
| Weight (in Package)                                   | Approx. 500 g   |
| Accessories   | Instruction Sheet (This sheet), Startup Guide, Utility Disk (CD-ROM)*7<br>Alarm Output Connector*8, AC Adapter*9, *10, DC Cable*10, and Dedicated Connection Cable*11 |

\*1: Only supported for KM50-C and KM50-E.

\*2: Automatically writes the data to the SD memory card when the internal memory reaches its capacity and continues recording until the SD card memory capacity reaches its limit. The unit stops operation if there is no SD memory card inserted when the internal memory reaches its capacity. (Recording can be resumed after inserting an SD memory card and outputting the data to it at a press of button.)

\*3: Continues the recording of the latest measured values until the internal memory reaches its capacity. (If the internal memory capacity exceeds the capacity, data is overwritten from the oldest one in the memory.)

\*4: Output when the integrated power upper limit specified in THR mode is exceeded.

\*5: The maximum load is applied when 10 KM50-□ units are connected; and the minimum load, when a single KM20-B40-FLK is connected.

\*6: The vibration resistance when mounted using the ZN9-EM01-S magnets (separately sold): 10 to 55 Hz, 0.3mm double amplitude, acceleration: 20m/s<sup>2</sup> for each in X, Y and Z directions for 50 min. The installation place must be free from physical shock.

\*7: The provided software operating environment/OS: Windows XP / Windows Vista / Windows 7; CPU: Intel-compatible processor 1.5GHz or higher; Memory: 1 GB or more (Recommended: 2 GB or more)

\*8: OMRON's XW4B-02B1-H1 connector.

\*9: This provided AC adapter must be used.

\*10: An AC adapter is provided in the ZN-KMX21 package; and a DC cable and ferrite core are included in the ZN-KMX21-A package.

\*11: Order OMRON's ZN9-KMC30 cable if dedicated cables are required.

### ● Declaration of hazardous substances

| Name      | Toxic or hazardous substances and elements |              |              |                              |                               |                                      |
|-----------|--|--------------|--------------|------------------------------|-------------------------------|--------------------------------------|
|           | Lead (Pb)                                  | Mercury (Hg) | Cadmium (Cd) | Hexavalent chromium (Cr(VI)) | Polybrominated biphenyl (PBB) | Polybrominated diphenyl ether (PBDE) |
| PCB       | -  | ✓            | ✓            | ✓                            | ✓                             | ✓                                    |
| Enclosure | ✓  | ✓            | ✓            | ✓                            | ✓                             | ✓                                    |
| Accessory | ✓  | ✓            | ✓            | ✓                            | ✓                             | ✓                                    |
| Cable     | -  | -            | -            | ✓                            | ✓                             | ✓                                    |

✓ : Indicates that this toxic or hazardous substance contained in all of the homogeneous materials for this part is below the limit requirement in SJ/T11363-2006.

-: Indicates that this toxic or hazardous substance contained in at least one of the homogeneous materials used for this part is above the limit requirement in SJ/T11363-2006.

## Mounting

This product is precision equipment. Be careful not to drop the product when mounting it.

Do not drop the product or apply strong impact to the product. If strong impact is applied to the product, stop using the product.

### 1. When using mounting screw holes

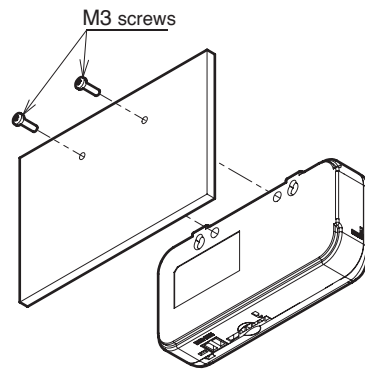

The unit screw hole depth is 4 mm. Be careful not to tighten the screw for more than 4 mm.

The product can be mounted with magnet by mounting mounting magnets (ZN9-EM01-S, sold separately) to the screw hole. (tightening torque: 0.4 N/cm to 0.6 N/cm)

Do not stress to the sensor head cables, when mounting the magnet.

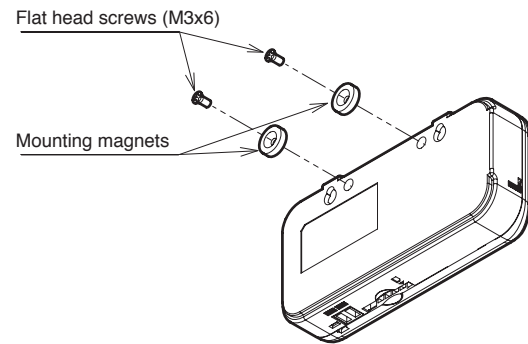

### 2. When using screw hook holes

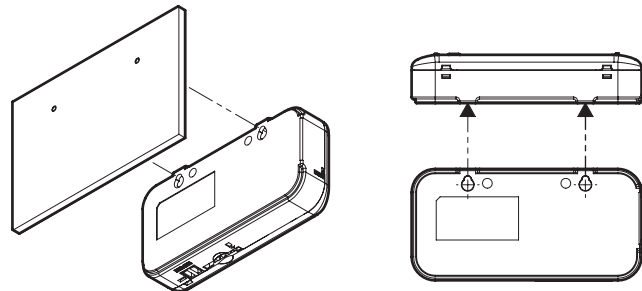

There are two hook holes below the convex section of the upper unit. Use M3 screws to hook the screw head on the screw hook holes. Set an interval of 2.5 mm or more between the bottom of the screw head and the wall surface.

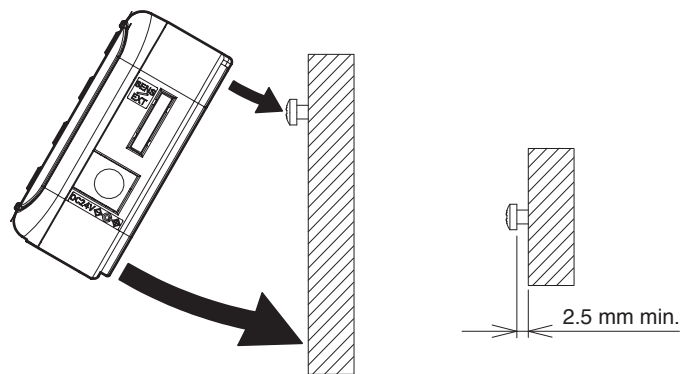

Enlarged view of the hook screw

### 3. Floor installation

Use the product on a desk, etc. Be careful of the installation location not to drop the product.

### 4. Inserting the SD card

Insert an SD card into the SD card connector at the bottom of the unit. Insert it with the terminal side of the SD card to the front side of the unit.

### 5. Mounting the alarm output terminal

Connect OUT and GND to the load according to the output specifications. Insert the signal line to the alarm output connector and tighten it with flathead screwdriver.

### 6. Connecting the sensor to the power monitor/sensor KM□□

Connect the terminal part of the provided dedicated cable to KM□□. Connect the RS-485(+) side to RS-485(+) of the KM□□ side, and the RS-485(-) side to RS-485(-). (Recommended tightening torque: 0.69 to 0.88 Nm)

Insert the connector (male) into the sensor head connector (female) of the right side of the unit.

### 7. Turning ON the power supply of KM-□□

Turn ON the power supply of the KM series first to initialize the sensor unit normally.

### 8. KM series settings

Set the KM series as shown below. For details, refer to the instruction manual of the KM series.

Communication Speed: 38.4 kbps

Data Bit Length: 7-bit

Stop Bit Length: 2-bit

Vertical Parity: EVEN

When connecting multiple KM series, assign unique consecutive numbers for the unit No. of each device.

### 9. Turning ON the power supply of the unit

(1) Insert the plug of the AC adapter or DC cable into the power supply input terminal of the unit.

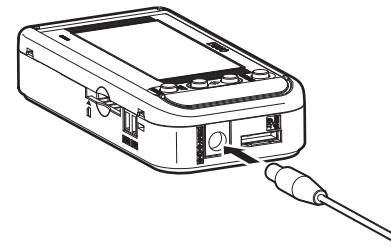

(2) For AC adapter, connect the AC plug into an outlet (100 VAC to 240 VAC). For DC cable, connect the cable with white line to the power supply (24 VDC±10%) and cable without a line into the 0 V.

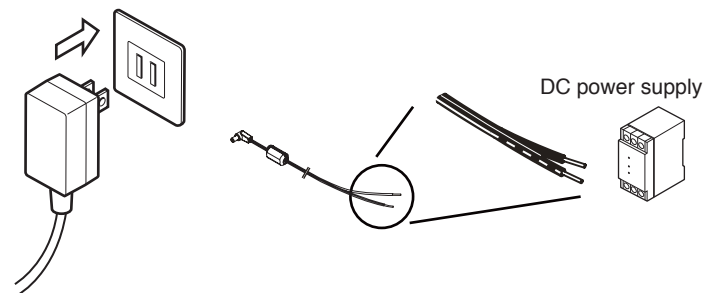

AC adapter

DC power supply

### 10. Unit Setting

Select UNIT in FUN mode and input the number of the connected KM series units. The Power Sensor Station resets itself to apply the setting, when the mode is changed from FUN to THR.

## Transition of Major Menu Displays

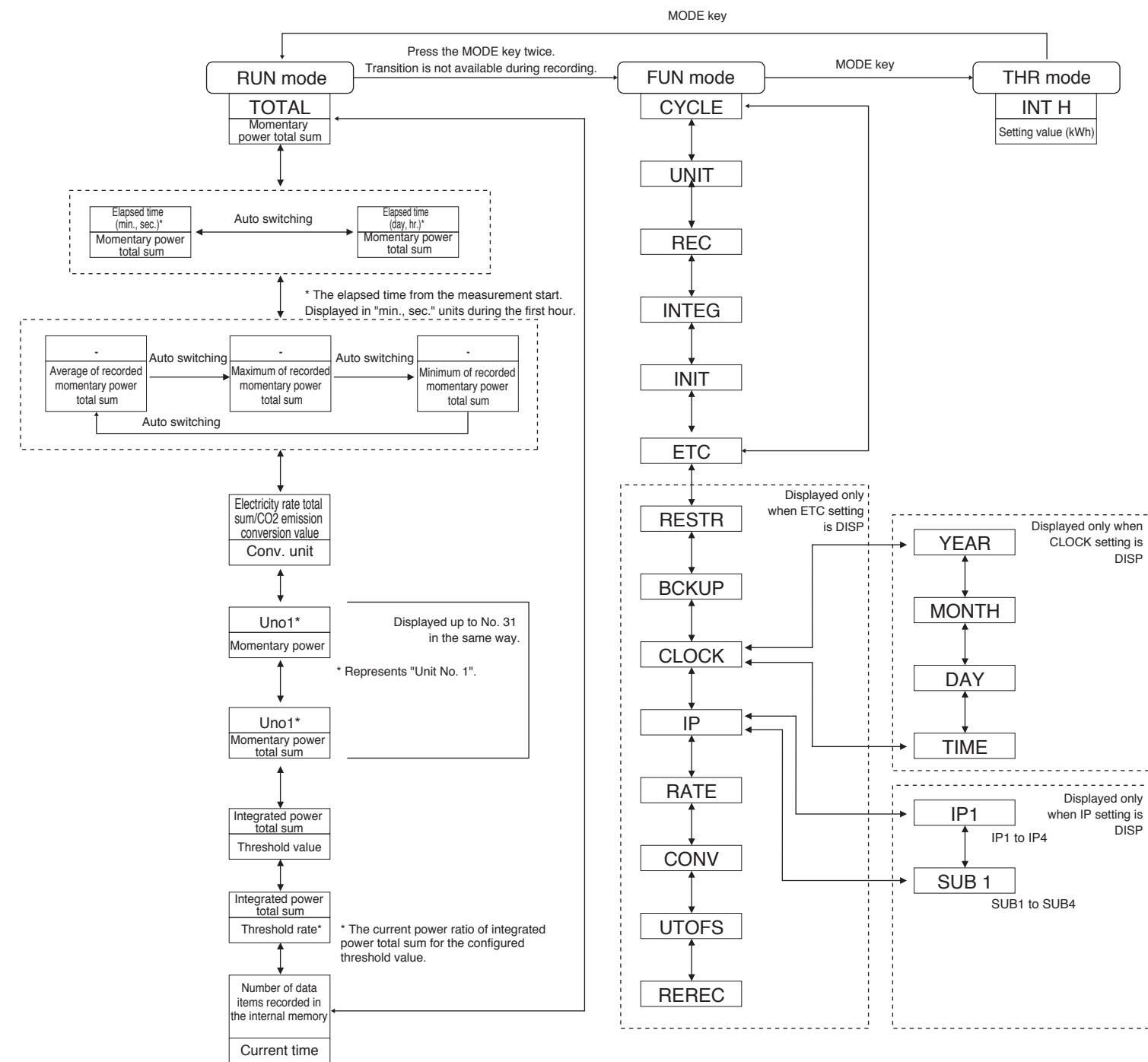



## List of Major Setting Items

### ● Operation mode

| Mode | Item                       | Description  |
|------|----------------------------|--|
| RUN  | Measurement execution mode | Performs measurement/recording.                      |
| FUN  | Function setting mode      | Sets various parameters.                             |
| THR  | Threshold setting mode     | Performs condition settings regarding alarm outputs. |

### ● FUN mode

| Item  | Overview  | Description  | Setting range                | Default |
|-------|---|--|------------------------------|---------|
| CYCLE | Recording interval setting                                | Sets an recording interval of the measured value.  | 1s/2s/5s/10s<br>20s/30s/1min | 10s     |
| UNIT  | No. of connected Power Sensor Station/Monitor             | Sets the number of connected Power Sensor Stations/Monitors.   | 1 to 31                      | 1       |
| REC   | Recording operation mode setting                          | Sets operation for a case in which the internal memory capacity reaches the limit during recording.  | CONT/RING                    | CONT    |
| CONT  | Continue mode   | Outputs a recorded value to the SD card and continues recording when the internal memory capacity reaches the limit during recording.  | -                            | -       |
| RING  | Ring mode   | Overwrites a recorded value to the SD card and continues recording when the internal memory capacity reaches the limit during recording.   | -                            | -       |
| INTEG | Setting of reset interval of integrated power consumption | Specifies the integrated power reset interval. The integrated power value is reset at the specified time interval, displaying the data belonging to that interval.   | OFF/30 m<br>1 h/24 h         | OFF     |
| INIT  | Setting initialization                                    | Initializes the unit setting to the factory default value. Holding the SET/REC/STOP key starts initialization. Changing measurement operation mode with the MODE key after DONE is displayed initializes the settings and the unit restarts.   | -                            | -       |
| ETC   | Display setting for other items                           | Sets whether displaying other setting items.   | OFF/DISP                     | OFF     |
| RESTR | Read setting data   | Recovers the setting from the SD card in which the setting data of the sensor unit is stored. Insert the SD card and hold the SET/REC/STOP key. Writing completes when DONE is displayed.  | -                            | -       |
| BCKUP | Write setting data  | Writes the setting data of the sensor unit to the SD card as a backup. Insert the SD card and hold the SET/REC/STOP key. Writing completes when DONE is displayed.   | -                            | -       |
| CLOCK | Time setting  | Sets whether displaying the time setting item.   | OFF/DISP                     | OFF     |
| IP    | IP address display setting                                | Sets whether performing IP address setting.  | OFF/DISP                     | OFF     |
| RATE  | Rate conversion setting                                   | Sets the conversion coefficient to convert the integrated power consumption to rate.   | 0.000 to 99.999              | 0       |
| CONV  | Conversion unit setting                                   | Sets the conversion unit.  | JPY/USD/EUR<br>CNY/KRW/CO2   | JPY     |
| UTOFS | Unit No. offset setting                                   | Specifies the starting (offset) unit number set for the Power Sensor/Monitor units to be connected. To use the unit numbers from No.10 to No.15, for example, "10" is set for the offset number (this setting item), while "6" is set for the number of Power Sensor/Monitor units to be connected (UNIT). | 1 to 99                      | 1       |
| REREC | Power failure REC restoration                             | Sets whether writing data and starting recording at next startup after power shutdown during recording.  | OFF/ON                       | OFF     |

### ● THR mode

| Displayed item    | Overview  | Setting range | Default |
|-------------------|---|---------------|---------|
| INT H (Unit: kWh) | Upper threshold setting of the integrated power consumption (kWh or more) | 0 to 99999    | 0       |

## Major Error Displays and Countermeasures

| Display | Overview                            | Description   |
|---------|-------------------------------------|---|
| E1100   | Recorded data writing failure       | Failed to write recorded data to the SD memory card. Insert a write-enabled SD card. Hold the MODE key for 3 seconds or more to cancel the error display.                                       |
| E2001   | Sensor error                        | A sensor different from the one auto-registered at startup is mounted. Restart the unit.  |
| E3000   | No SD memory card inserted          | An SD memory card is not inserted. Insert a write-enabled SD card. Hold the MODE key for 3 seconds or more to cancel the error display.   |
| E3001   | Unable to access the SD memory card | The SD memory card cannot be accessed due to the battery voltage drop. Replace the batteries or connect to the AC adapter. Hold the MODE key for 3 seconds or more to cancel the error display. |
| E3002   | Write-protected SD memory card      | The SD memory card is write-protected. Replace it with a write-enabled one. Hold the MODE key for 3 seconds or more to cancel the error display.  |
| E3003   | SD card recognition error           | Failed to recognize the SD card. Insert a normal SD memory card. Hold the MODE key for 3 seconds or more to cancel the error display.   |
| E5000   | Invalid setting file data           | The setting data in the SD memory card is invalid e.g. an invalid model type or setting values. Hold the MODE key for 3 seconds or more to cancel the error display.                            |
| E5001   | Setting file writing failure        | Failed to write setting files to the SD memory card. Insert a write-enabled SD card. Hold the MODE key for 3 seconds or more to cancel the error display.                                       |
| E5002   | Setting file reading failure        | There is no setting files contained in the SD memory card. Replace it with an SD memory card with setting files. Hold the MODE key for 3 seconds or more to cancel the error display.           |
| HARD    | Hardware error                      | There may be a failure on the hardware. Please contact the distributor or OMRON representative office.  |

## Recording Interval and Internal Memory

An example of the possible recording time in the internal memory that varies depending on the recording interval setting is shown below.

| Recording Interval | Example of possible recording time in the internal memory |                              |
|--------------------|---|------------------------------|
|                    | Max. load<br>(KM50 x 31 units)                            | Min. load<br>(KM20 x 1 unit) |
| 1 second           | -   | Approx. 1 hr. 50 min.        |
| 2 seconds          | -   | Approx. 3 hr. 40 min.        |
| 5 seconds          | -   | Approx. 9 hr. 30 min.        |
| 10 seconds         | -   | Approx. 19 hr.               |
| 20 seconds         | -   | Approx. 1 day 14 hr.         |
| 30 seconds         | Approx. 1 hr. 40 min.                                     | Approx. 2 days               |
| 1 minute           | Approx. 3 hr. 20 min.                                     | Approx. 4 days               |

## Connected Units and Recording Interval

The possible minimum recording interval varies depending on the number of power sensors/monitors. Check the following table of the number of units that can be connected to set the recording interval.

| Minimum recording interval | Number of units |
|----------------------------|-----------------|
| 1 second                   | 1 unit          |
| 2 seconds                  | Up to 2 units   |
| 5 seconds                  | Up to 6 units   |
| 10 seconds                 | Up to 12units   |
| 20 seconds                 | Up to 24 units  |
| 30 seconds                 | Up to 31 units  |
| 1 minute                   |                 |

### ● Notice for Korea Radio Law

A 급 기기(업무용 방송통신기자재)  
이 기기는 업무용 (A 급) 전자파적합기기로서 판매자 또는 사용자는 이 점을 주의하시기 바라며,가정외의 지역에서 사용하는 것을 목적으로 합니다.

## Suitability for Use

Omron Companies shall not be responsible for conformity with any standards, codes or regulations which apply to the combination of the Product in the Buyer's application or use of the Product. At Buyer's request, Omron will provide applicable third party certification documents identifying ratings and limitations of use which apply to the Product. This information by itself is not sufficient for a complete determination of the suitability of the Product in combination with the end product, machine, system, or other application or use. Buyer shall be solely responsible for determining appropriateness of the particular Product with respect to Buyer's application, product or system. Buyer shall take application responsibility in all cases.

NEVER USE THE PRODUCT FOR AN APPLICATION INVOLVING SERIOUS RISK TO LIFE OR PROPERTY WITHOUT ENSURING THAT THE SYSTEM AS A WHOLE HAS BEEN DESIGNED TO ADDRESS THE RISKS, AND THAT THE OMRON PRODUCT(S) IS PROPERLY RATED AND INSTALLED FOR THE INTENDED USE WITHIN THE OVERALL EQUIPMENT OR SYSTEM.

See also Product catalog for Warranty and Limitation of Liability.

### OMRON Corporation Industrial Automation Company Tokyo, JAPAN Contact: [www.ia.omron.com](http://www.ia.omron.com)

#### Regional Headquarters

■ **OMRON EUROPE B.V.**  
Sensor Business Unit  
Carl-Benz-Str. 4, D-71154 Nufringen, Germany  
Tel: (49) 7032-811-0/Fax: (49) 7032-811-199

■ **OMRON ELECTRONICS LLC**  
2895 Greenspoint Parkway, Suite 200  
Hoffman Estates, IL 60169 U.S.A.  
Tel: (1) 847-843-7900/Fax: (1) 847-843-7787

■ **OMRON ASIA PACIFIC PTE. LTD.**  
No. 438A Alexandra Road # 05-05/08 (Lobby 2),  
Alexandra Technopark,  
Singapore 119967  
Tel: (65) 6835-3011/Fax: (65) 6835-2711

■ **OMRON (CHINA) CO., LTD.**  
Room 2211, Bank of China Tower,  
200 Yin Cheng Zhong Road,  
PuDong New Area, Shanghai, 200120, China  
Tel: (86) 21-5037-2222/Fax: (86) 21-5037-2200