



Mitsubishi Programmable Controller

MELSEC iQ-R
series

MELSEC iQ-R I/O Module (With Diagnostic Functions) User's Manual (Startup)



-RX40NC6B
-RY40PT5B



SAFETY PRECAUTIONS

(Read these precautions before using this product.)

Before using this product, please read this manual and the relevant manuals carefully and pay full attention to safety to handle the product correctly.

The precautions given in this manual are concerned with this product only. For the safety precautions of the programmable controller system, refer to the MELSEC iQ-R Module Configuration Manual.

In this manual, the safety precautions are classified into two levels: "  WARNING" and "  CAUTION".

 WARNING	Indicates that incorrect handling may cause hazardous conditions, resulting in death or severe injury.
 CAUTION	Indicates that incorrect handling may cause hazardous conditions, resulting in minor or moderate injury or property damage.

Under some circumstances, failure to observe the precautions given under "  CAUTION" may lead to serious consequences.

Observe the precautions of both levels because they are important for personal and system safety.

Make sure that the end users read this manual and then keep the manual in a safe place for future reference.

[Design Precautions]

WARNING

- Configure safety circuits external to the programmable controller to ensure that the entire system operates safely even when a fault occurs in the external power supply or the programmable controller. Failure to do so may result in an accident due to an incorrect output or malfunction.
 - (1) Emergency stop circuits, protection circuits, and protective interlock circuits for conflicting operations (such as forward/reverse rotations or upper/lower limit positioning) must be configured external to the programmable controller.
 - (2) When the programmable controller detects an abnormal condition, it stops the operation and all outputs are:
 - Turned off if the overcurrent or overvoltage protection of the power supply module is activated.
 - Held or turned off according to the parameter setting if the self-diagnostic function of the CPU module detects an error such as a watchdog timer error.
 - (3) All outputs may be turned on if an error occurs in a part, such as an I/O control part, where the CPU module cannot detect any error. To ensure safety operation in such a case, provide a safety mechanism or a fail-safe circuit external to the programmable controller. For a fail-safe circuit example, refer to "General Safety Requirements" in the MELSEC iQ-R Module Configuration Manual.
 - (4) Outputs may remain on or off due to a failure of a component such as a relay and transistor in an output circuit. Configure an external circuit for monitoring output signals that could cause a serious accident.
 - In an output circuit, when a load current exceeding the rated current or an overcurrent caused by a load short-circuit flows for a long time, it may cause smoke and fire. To prevent this, configure an external safety circuit, such as a fuse.
 - Configure a circuit so that the programmable controller is turned on first and then the external power supply. If the external power supply is turned on first, an accident may occur due to an incorrect output or malfunction.
 - For the operating status of each station after a communication failure, refer to manuals relevant to the network. Incorrect output or malfunction due to a communication failure may result in an accident.
 - When connecting an external device with a CPU module or intelligent function module to modify data of a running programmable controller, configure an interlock circuit in the program to ensure that the entire system will always operate safely. For other forms of control (such as program modification, parameter change, forced output, or operating status change) of a running programmable controller, read the relevant manuals carefully and ensure that the operation is safe before proceeding. Improper operation may damage machines or cause accidents.
 - Especially, when a remote programmable controller is controlled by an external device, immediate action cannot be taken if a problem occurs in the programmable controller due to a communication failure. To prevent this, configure an interlock circuit in the program, and determine corrective actions to be taken between the external device and CPU module in case of a communication failure.
-

[Design Precautions]

WARNING

- Do not write any data to the "system area" and "write-protect area" of the buffer memory in the module. Also, do not use any "use prohibited" signals as an output signal from the CPU module to each module. Doing so may cause malfunction of the programmable controller system. For the "system area", "write-protect area", and the "use prohibited" signals, refer to the user's manual for the module used.
 - If a communication cable is disconnected, the network may be unstable, resulting in a communication failure of multiple stations. Configure an interlock circuit in the program to ensure that the entire system will always operate safely even if communications fail. Failure to do so may result in an accident due to an incorrect output or malfunction.
 - To maintain the safety of the programmable controller system against unauthorized access from external devices via the network, take appropriate measures. To maintain the safety against unauthorized access via the Internet, take measures such as installing a firewall.
-

[Design Precautions]

CAUTION

- Do not install the control lines or communication cables together with the main circuit lines or power cables. Keep a distance of 100mm or more between them. Failure to do so may result in malfunction due to noise.
 - During control of an inductive load such as a lamp, heater, or solenoid valve, a large current (approximately ten times greater than normal) may flow when the output is turned from off to on. Therefore, use a module that has a sufficient current rating.
 - After the CPU module is powered on or is reset, the time taken to enter the RUN status varies depending on the system configuration, parameter settings, and/or program size. Design circuits so that the entire system will always operate safely, regardless of the time.
 - Do not power off the programmable controller or reset the CPU module while the settings are being written. Doing so will make the data in the flash ROM and SD memory card undefined. The values need to be set in the buffer memory and written to the flash ROM and SD memory card again. Doing so also may cause malfunction or failure of the module.
 - When changing the operating status of the CPU module from external devices (such as the remote RUN/STOP functions), select "Do Not OPEN in Program" for "Open Method Setting" in the module parameters. If "OPEN in Program" is selected, an execution of the remote STOP function causes the communication line to close. Consequently, the CPU module cannot reopen the line, and external devices cannot execute the remote RUN function.
-

[Installation Precautions]

WARNING

- Shut off the external power supply (all phases) used in the system before mounting or removing the module. Failure to do so may result in electric shock or cause the module to fail or malfunction.
-

[Installation Precautions]

CAUTION

- Use the programmable controller in an environment that meets the general specifications in the Safety Guidelines included with the base unit. Failure to do so may result in electric shock, fire, malfunction, or damage to or deterioration of the product.
 - To mount a module, place the concave part(s) located at the bottom onto the guide(s) of the base unit, and push in the module until the hook(s) located at the top snaps into place. Incorrect interconnection may cause malfunction, failure, or drop of the module.
 - When using the programmable controller in an environment of frequent vibrations, fix the module with a screw.
 - Tighten the screws within the specified torque range. Undertightening can cause drop of the screw, short circuit, or malfunction. Overtightening can damage the screw and/or module, resulting in drop, short circuit, or malfunction.
 - When using an extension cable, connect it to the extension cable connector of the base unit securely. Check the connection for looseness. Poor contact may cause malfunction.
 - When using an SD memory card, fully insert it into the SD memory card slot. Check that it is inserted completely. Poor contact may cause malfunction.
 - Securely insert an extended SRAM cassette into the cassette connector of the CPU module. After insertion, close the cassette cover and check that the cassette is inserted completely. Poor contact may cause malfunction.
 - Do not directly touch any conductive parts and electronic components of the module, SD memory card, extended SRAM cassette, or connector. Doing so can cause malfunction or failure of the module.
-

[Wiring Precautions]

WARNING

- Shut off the external power supply (all phases) used in the system before installation and wiring. Failure to do so may result in electric shock or cause the module to fail or malfunction.
 - After installation and wiring, attach the included terminal cover to the module before turning it on for operation. Failure to do so may result in electric shock.
-

[Wiring Precautions]

CAUTION

- Individually ground the FG and LG terminals of the programmable controller with a ground resistance of 100 ohms or less. Failure to do so may result in electric shock or malfunction.
 - Use applicable solderless terminals and tighten them within the specified torque range. If any spade solderless terminal is used, it may be disconnected when the terminal screw comes loose, resulting in failure.
 - Check the rated voltage and signal layout before wiring to the module, and connect the cables correctly. Connecting a power supply with a different voltage rating or incorrect wiring may cause fire or failure.
 - Connectors for external devices must be crimped or pressed with the tool specified by the manufacturer, or must be correctly soldered. Incomplete connections may cause short circuit, fire, or malfunction.
 - Securely connect the connector to the module. Poor contact may cause malfunction.
 - Do not install the control lines or communication cables together with the main circuit lines or power cables. Keep a distance of 100mm or more between them. Failure to do so may result in malfunction due to noise.
 - Place the cables in a duct or clamp them. If not, dangling cable may swing or inadvertently be pulled, resulting in damage to the module or cables or malfunction due to poor contact. Do not clamp the extension cables with the jacket stripped.
 - Check the interface type and correctly connect the cable. Incorrect wiring (connecting the cable to an incorrect interface) may cause failure of the module and external device.
 - Tighten the terminal screws or connector screws within the specified torque range. Undertightening can cause drop of the screw, short circuit, fire, or malfunction. Overtightening can damage the screw and/or module, resulting in drop, short circuit, fire, or malfunction.
 - When disconnecting the cable from the module, do not pull the cable by the cable part. For the cable with connector, hold the connector part of the cable. For the cable connected to the terminal block, loosen the terminal screw. Pulling the cable connected to the module may result in malfunction or damage to the module or cable.
 - Prevent foreign matter such as dust or wire chips from entering the module. Such foreign matter can cause a fire, failure, or malfunction.
 - A protective film is attached to the top of the module to prevent foreign matter, such as wire chips, from entering the module during wiring. Do not remove the film during wiring. Remove it for heat dissipation before system operation.
 - Programmable controllers must be installed in control panels. Connect the main power supply to the power supply module in the control panel through a relay terminal block. Wiring and replacement of a power supply module must be performed by qualified maintenance personnel with knowledge of protection against electric shock. For wiring, refer to the MELSEC iQ-R Module Configuration Manual.
 - For Ethernet cables to be used in the system, select the ones that meet the specifications in the user's manual for the module used. If not, normal data transmission is not guaranteed.
-

[Startup and Maintenance Precautions]

WARNING

- Do not touch any terminal while power is on. Doing so will cause electric shock or malfunction.
 - Correctly connect the battery connector. Do not charge, disassemble, heat, short-circuit, solder, or throw the battery into the fire. Also, do not expose it to liquid or strong shock. Doing so will cause the battery to produce heat, explode, ignite, or leak, resulting in injury and fire.
 - Shut off the external power supply (all phases) used in the system before cleaning the module or retightening the terminal screws, connector screws, or module fixing screws. Failure to do so may result in electric shock.
-

[Startup and Maintenance Precautions]

CAUTION

- When connecting an external device with a CPU module or intelligent function module to modify data of a running programmable controller, configure an interlock circuit in the program to ensure that the entire system will always operate safely. For other forms of control (such as program modification, parameter change, forced output, or operating status change) of a running programmable controller, read the relevant manuals carefully and ensure that the operation is safe before proceeding. Improper operation may damage machines or cause accidents.
 - Especially, when a remote programmable controller is controlled by an external device, immediate action cannot be taken if a problem occurs in the programmable controller due to a communication failure. To prevent this, configure an interlock circuit in the program, and determine corrective actions to be taken between the external device and CPU module in case of a communication failure.
 - Do not disassemble or modify the modules. Doing so may cause failure, malfunction, injury, or a fire.
 - Use any radio communication device such as a cellular phone or PHS (Personal Handy-phone System) more than 25cm away in all directions from the programmable controller. Failure to do so may cause malfunction.
 - Shut off the external power supply (all phases) used in the system before mounting or removing the module. Failure to do so may cause the module to fail or malfunction.
 - Tighten the screws within the specified torque range. Undertightening can cause drop of the component or wire, short circuit, or malfunction. Overtightening can damage the screw and/or module, resulting in drop, short circuit, or malfunction.
 - After the first use of the product, do not mount/remove the module to/from the base unit, and the terminal block to/from the module, and do not insert/remove the extended SRAM cassette to/from the CPU module more than 50 times (IEC 61131-2 compliant) respectively. Exceeding the limit may cause malfunction.
 - After the first use of the product, do not insert/remove the SD memory card to/from the CPU module more than 500 times. Exceeding the limit may cause malfunction.
 - Do not touch the metal terminals on the back side of the SD memory card. Doing so may cause malfunction or failure of the module.
 - Do not touch the integrated circuits on the circuit board of an extended SRAM cassette. Doing so may cause malfunction or failure of the module.
 - Do not drop or apply shock to the battery to be installed in the module. Doing so may damage the battery, causing the battery fluid to leak inside the battery. If the battery is dropped or any shock is applied to it, dispose of it without using.
-

[Startup and Maintenance Precautions]

CAUTION

- Startup and maintenance of a control panel must be performed by qualified maintenance personnel with knowledge of protection against electric shock. Lock the control panel so that only qualified maintenance personnel can operate it.
 - Before handling the module, touch a conducting object such as a grounded metal to discharge the static electricity from the human body. Failure to do so may cause the module to fail or malfunction.
-

[Operating Precautions]

CAUTION

- When changing data and operating status, and modifying program of the running programmable controller from an external device such as a personal computer connected to an intelligent function module, read relevant manuals carefully and ensure the safety before operation. Incorrect change or modification may cause system malfunction, damage to the machines, or accidents.
 - Do not power off the programmable controller or reset the CPU module while the setting values in the buffer memory are being written to the flash ROM in the module. Doing so will make the data in the flash ROM undefined. The values need to be set in the buffer memory and written to the flash ROM again. Doing so can cause malfunction or failure of the module.
-

[Disposal Precautions]

CAUTION

- When disposing of this product, treat it as industrial waste.
 - When disposing of batteries, separate them from other wastes according to the local regulations. For details on battery regulations in EU member states, refer to the MELSEC iQ-R Module Configuration Manual.
-

[Transportation Precautions]

CAUTION

- When transporting lithium batteries, follow the transportation regulations. For details on the regulated models, refer to the MELSEC iQ-R Module Configuration Manual.
 - The halogens (such as fluorine, chlorine, bromine, and iodine), which are contained in a fumigant used for disinfection and pest control of wood packaging materials, may cause failure of the product. Prevent the entry of fumigant residues into the product or consider other methods (such as heat treatment) instead of fumigation. The disinfection and pest control measures must be applied to unprocessed raw wood.
-

CONDITIONS OF USE FOR THE PRODUCT

(1) Mitsubishi programmable controller ("the PRODUCT") shall be used in conditions;

- i) where any problem, fault or failure occurring in the PRODUCT, if any, shall not lead to any major or serious accident; and
- ii) where the backup and fail-safe function are systematically or automatically provided outside of the PRODUCT for the case of any problem, fault or failure occurring in the PRODUCT.

(2) The PRODUCT has been designed and manufactured for the purpose of being used in general industries.

MITSUBISHI SHALL HAVE NO RESPONSIBILITY OR LIABILITY (INCLUDING, BUT NOT LIMITED TO ANY AND ALL RESPONSIBILITY OR LIABILITY BASED ON CONTRACT, WARRANTY, TORT, PRODUCT LIABILITY) FOR ANY INJURY OR DEATH TO PERSONS OR LOSS OR DAMAGE TO PROPERTY CAUSED BY the PRODUCT THAT ARE OPERATED OR USED IN APPLICATION NOT INTENDED OR EXCLUDED BY INSTRUCTIONS, PRECAUTIONS, OR WARNING CONTAINED IN MITSUBISHI'S USER, INSTRUCTION AND/OR SAFETY MANUALS, TECHNICAL BULLETINS AND GUIDELINES FOR the PRODUCT.

("Prohibited Application")

Prohibited Applications include, but not limited to, the use of the PRODUCT in;

- Nuclear Power Plants and any other power plants operated by Power companies, and/or any other cases in which the public could be affected if any problem or fault occurs in the PRODUCT.
- Railway companies or Public service purposes, and/or any other cases in which establishment of a special quality assurance system is required by the Purchaser or End User.
- Aircraft or Aerospace, Medical applications, Train equipment, transport equipment such as Elevator and Escalator, Incineration and Fuel devices, Vehicles, Manned transportation, Equipment for Recreation and Amusement, and Safety devices, handling of Nuclear or Hazardous Materials or Chemicals, Mining and Drilling, and/or other applications where there is a significant risk of injury to the public or property.

Notwithstanding the above, restrictions Mitsubishi may in its sole discretion, authorize use of the PRODUCT in one or more of the Prohibited Applications, provided that the usage of the PRODUCT is limited only for the specific applications agreed to by Mitsubishi and provided further that no special quality assurance or fail-safe, redundant or other safety features which exceed the general specifications of the PRODUCTS are required. For details, please contact the Mitsubishi representative in your region.

INTRODUCTION

Thank you for purchasing the Mitsubishi MELSEC iQ-R series programmable controllers.

This manual describes the specifications, procedures before operation, installation, and wiring of the relevant products listed below.

Before using this product, please read this manual and the relevant manuals carefully and develop familiarity with the functions and performance of the MELSEC iQ-R series programmable controller to handle the product correctly.

Please make sure that the end users read this manual.



Relevant products

RX40NC6B, RY40PT5B

COMPLIANCE WITH EMC AND LOW VOLTAGE DIRECTIVES

Method of ensuring compliance

To ensure that Mitsubishi programmable controllers maintain EMC and Low Voltage Directives when incorporated into other machinery or equipment, certain measures may be necessary. Please refer to one of the following manuals.

-  MELSEC iQ-R Module Configuration Manual
-  Safety Guidelines (This manual is included with the base unit.)

The CE mark on the side of the programmable controller indicates compliance with EMC and Low Voltage Directives.

Additional measures

No additional measures are necessary for the compliance of this product with EMC and Low Voltage Directives.

CONTENTS

SAFETY PRECAUTIONS	1
CONDITIONS OF USE FOR THE PRODUCT	9
INTRODUCTION	9
COMPLIANCE WITH EMC AND LOW VOLTAGE DIRECTIVES	10
RELEVANT MANUALS	12
TERMS	12
CHAPTER 1 PART NAMES	13
CHAPTER 2 SPECIFICATIONS	15
2.1 Performance Specifications	15
Input module with diagnostic functions	15
Output module with diagnostic functions	17
CHAPTER 3 FUNCTION LIST	20
CHAPTER 4 PROCEDURES BEFORE OPERATION	22
CHAPTER 5 INSTALLATION AND WIRING	24
5.1 Before Using the I/O Modules with Diagnostic Functions	24
Input module with diagnostic functions	24
Output module with diagnostic functions	25
5.2 Wiring	27
5.3 Input Wiring Examples	28
APPENDICES	30
Appendix 1 External Dimensions	30
INDEX	32
REVISIONS	34
WARRANTY	35
TRADEMARKS	36

RELEVANT MANUALS

User's manuals relevant to the module

Manual name [manual number]	Description	Available form
MELSEC iQ-R I/O Module (With Diagnostic Functions) User's Manual (Startup) [SH-081619ENG] (this manual)	Specifications, procedures before operation, installation, and wiring of the I/O module with diagnostic functions	Print book e-Manual PDF
MELSEC iQ-R I/O Module (With Diagnostic Functions) User's Manual (Application) [SH-081621ENG]	Functions, parameter settings, troubleshooting, I/O signals, and buffer memory of the I/O module with diagnostic functions	Print book e-Manual PDF
Before Using the Product [BCN-P5999-0209]	Compatible models, specifications, and installation procedure of the Q6TE-18SN spring clamp terminal block	Print book PDF

This manual does not include detailed information on the following:

- General specifications
- Applicable combinations of CPU modules and the other modules, and the number of mountable modules
- Applicable combinations of the remote head module and the other modules, and the number of mountable modules
- Installation

For details, refer to the following.

 MELSEC iQ-R Module Configuration Manual

This manual does not include information on the module function blocks.

For details, refer to the Function Block Reference for the module used.

Point

e-Manual refers to the Mitsubishi FA electronic book manuals that can be browsed using a dedicated tool.

e-Manual has the following features:

- Required information can be cross-searched in multiple manuals.
- Other manuals can be accessed from the links in the manual.
- The hardware specifications of each part can be found from the product figures.
- Pages that users often browse can be bookmarked.

TERMS

Unless otherwise specified, this manual uses the following terms.

Term	Description
CPU module	A generic term for the MELSEC iQ-R series CPU modules
Engineering tool	Another term for GX Works3
GX Works3	The product name of the software package for the MELSEC programmable controllers
I/O module with diagnostic functions	The abbreviation for the MELSEC iQ-R series I/O module with diagnostic functions
Power supply module	A generic term for the MELSEC iQ-R series power supply modules
Remote head module	The abbreviation for the RJ72GF15-T2 CC-Link IE Field Network remote head module

1 PART NAMES

This chapter describes the part names of the I/O module with diagnostic functions.

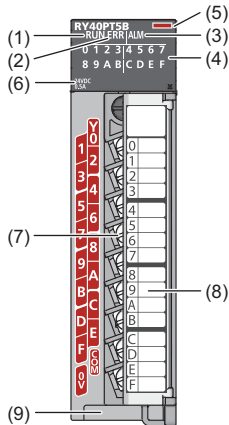

No.	Name	Description
(1)	RUN LED	Indicates the operating status. On: In operation Flashing (400ms cycles): Selected as a module for the online module change Off: 5V power supply interrupted, watchdog timer error occurred, or module replacement allowed in the process of the online module change
(2)	ERR LED	Indicates the error status of each I/O terminal in combination with the I/O status indicator LED. (📖 MELSEC iQ-R I/O Module (With Diagnostic Functions) User's Manual (Application)) On: Error occurred Off: Normal operation
(3)	ALM LED	Indicates the alarm status of each I/O terminal in combination with the I/O status indicator LED. (📖 MELSEC iQ-R I/O Module (With Diagnostic Functions) User's Manual (Application)) On: Alarm occurred Off: Normal operation
(4)	I/O status indicator LED	Indicates the I/O status of each I/O terminal, error status, or alarm status according to the setting of "LED display setting when error occurred". • When "Hide abnormal occurrence points" is set On: I/O signals on Off: I/O signals off • When "Always display abnormal occurrence points" or "Switching display of input status and alarm (1 second intervals)" is set The I/O where an error has occurred can be specified. For details on the LED indication, refer to the following. 📖 MELSEC iQ-R I/O Module (With Diagnostic Functions) User's Manual (Application)
(5)	Module identification lamp	Light gray: Input Dark orange: Output
(6)	Rate indication	Indicates the rated voltage, and input current or output current.
(7)	Terminal block	18-point screw terminal block. For the terminal layout, refer to the following. 👉 Page 15 Performance Specifications
(8)	Terminal block cover	Covers for preventing electric shock while the power is on
(9)	Production information marking	Shows the production information (16 digits) of the module.

MEMO

2 SPECIFICATIONS



This chapter describes the performance specifications.

2.1 Performance Specifications

This section describes the performance specifications of the I/O module with diagnostic functions.

Input module with diagnostic functions

RX40NC6B DC input module

Item	Specifications	
Number of input points	16 points	
Rated input voltage	24VDC (ripple ratio: within 5%) (allowable voltage range: 20.4 to 28.8VDC)	
Rated input current	6.0mA TYP. (at 24VDC)	
ON voltage/ON current	14V or higher/3.5mA or higher	
OFF voltage/OFF current	6V or lower/1mA or lower	
Input resistance	Approx. 4.0k Ω	
Response time	 Page 16 Input response time	
Disconnection (no connection) detection current	0.3mA or lower/point ^{*1}	
External power supply	Voltage	24VDC (ripple ratio: within 5%) (allowable voltage range: 20.4 to 28.8VDC)
	Current	130mA (at 24VDC)
Withstand voltage	510VACrms, 1 minute	
Isolation resistance	10M Ω or higher by isolation resistance tester	
Noise immunity	Simulator noise 500Vp-p, noise width 1 μ s, noise frequency 25 to 60Hz (noise simulator condition)	
Protection degree	IP2X	
Wiring method for common	16 points/common (common terminal: TB18)	
Number of occupied I/O points	32 points (I/O assignment: Input 32 points)	
Interrupt function	Available (can be set in the parameters of the CPU module)	
External interface	18-point screw terminal block (M3 \times 6 screw)  Page 27 Wiring	
Internal current consumption (5VDC)	450mA (TYP. all points ON)	
Weight	0.25kg	

*1 When the input current is 0.3mA/point or lower, a disconnection (no connection) is detected. When the leakage current of the input device is 0.3mA/point or lower, connect a bleeder resistance (resistance value as a guide: approx. 56k Ω) in parallel near the device connected.

■Circuit configuration

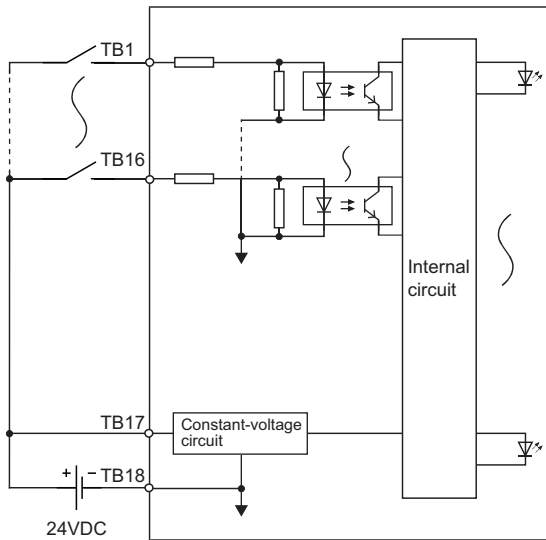

■Terminal connection

Connection diagram viewed from the front of the module

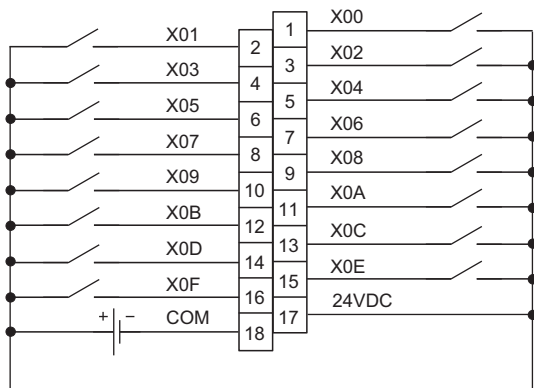

X00 to X0F are signal names.

The number of 1 to 18 indicates the terminal number.

■Input response time

Timing	Setting value				
	1ms	5ms	10ms ^{*1}	20ms	70ms
OFF→ON (MAX)	1ms	5ms	10ms	20ms	70ms
ON→OFF (MAX)	1ms	5ms	10ms	20ms	70ms

*1 The default value of input response time is 10ms.

Output module with diagnostic functions

R40PT5B transistor output module

Item		Specifications
Number of output points		16 points
Rated load voltage		24VDC (allowable voltage range: 20.4 to 28.8VDC)
Maximum load current		0.5A/point, 5A/common
Maximum inrush current		Current is to be limited by the overload protection function.
Leakage current at OFF		0.3mA or lower
Maximum voltage drop at ON		1.0VDC (TYP.) 0.5A
Response time	OFF→ON	0.5ms or less
	ON→OFF	1.5ms or less
Short-circuit (ground fault) detection current		0.5A or higher/point*1
Disconnection (no connection) detection current		3mA or lower/point*2
Surge suppressor		Zener diode
Fuse		None
External power supply	Voltage	24VDC (ripple ratio: within 5%) (allowable voltage range: 20.4 to 28.8VDC)
	Current	87mA (at 24VDC)
Withstand voltage		510VACrms, 1 minute
Isolation resistance		10MΩ or higher by isolation resistance tester
Noise immunity		Simulator noise 500Vp-p, noise width 1μs, noise frequency 25 to 60Hz (noise simulator condition)
Protection degree		IP2X
Wiring method for common		16 points/common (common terminal: TB18)
Number of occupied I/O points		32 points (I/O assignment: Output 32 points)
Protection function	Overload protection	Limited current when detecting overcurrent: 1.0A or higher/point Activated to each point. (☞ Page 18 Protection function)
	Overheat protection	Activated to each point. (☞ Page 18 Protection function)
External interface		18-point screw terminal block (M3×6 screw) ☞ Page 27 Wiring
Internal current consumption (5VDC)		190mA (TYP. all points ON)
Weight		0.24kg

*1 The detection is possible when the output is on. When the output current is 0.5A/point or higher, a short circuit is detected.

*2 The minimum load current (at output ON) of when the disconnection detection function is used is 3mA/point. A load of 3mA/point or lower is used, a disconnection is detected erroneously at output OFF.

■Circuit configuration

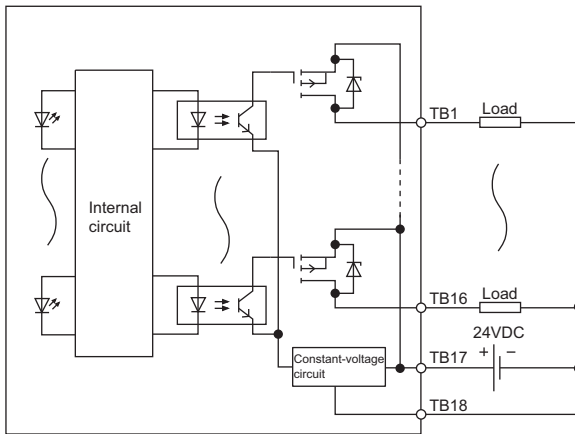

■Terminal connection

Connection diagram viewed from the front of the module

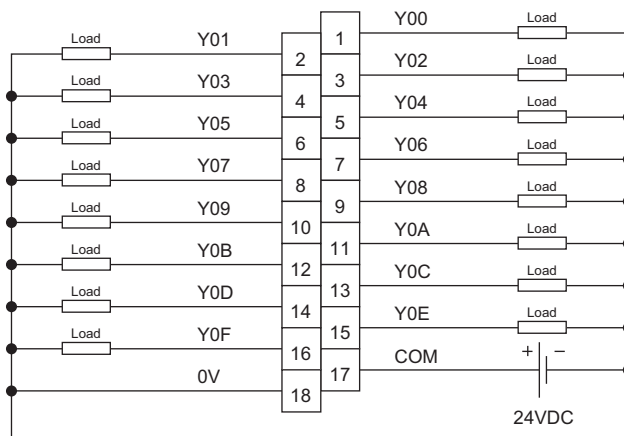

Y00 to Y0F are signal names.

The number of 1 to 18 indicates the terminal number.

Protection function

The output module with diagnostic functions is equipped with the overload protection function and overheat protection function.

Function	Description
Overload protection ^{*1}	<ul style="list-style-type: none"> If the output module with diagnostic functions detects an overcurrent, current limiter operation^{*2} is activated to limit the output current. For the overcurrent detection value and limit current, check the "Overload protection" column of the specifications of the module. If the load current falls below the overcurrent detection value, the normal operation resumes.
Overheat protection ^{*1}	<ul style="list-style-type: none"> If the output module with diagnostic functions continues to output an overcurrent due to overload, heat is generated inside the module. If the module detects a high heat in its inside, it turns off the output. The number of output points where the overheat protection function is activated simultaneously varies depending on modules. Check the "Overheat protection" column of the specifications of the module. If the high temperature drops, the normal operation resumes automatically.

*1 This function is intended to protect the internal circuit of a module, not to protect external devices.

Additionally, an abnormal load can cause the module internal temperature to rise, resulting in deterioration of the output elements and discoloration of the case and printed-circuit board. In the event of an abnormal load, turn off the corresponding output immediately and eliminate the cause.

*2 This operation limits an overcurrent to a certain current value, which allows a continuous output.

3 FUNCTION LIST

This chapter lists the functions of the I/O module with diagnostic functions. For details on the functions, refer to the following.
 MELSEC iQ-R I/O Module (With Diagnostic Functions) User's Manual (Application)

Item		Description	
Input function	Input response time setting	Allows changing the input response time of the input module with diagnostic functions on a point-by-point basis. The input module with diagnostic functions takes in external input for the set input response time.	
	Input HOLD/CLEAR setting function	Sets whether to hold or clear the value that was input just before an error if the input module with diagnostic functions detects an error (moderate error, minor error, alarm).	
	Input delay function ^{*1}	OFF delay	holds the ON state of a signal for a certain period of time (turning off an X signal after a predetermined time passed) when an external input has changed from on to off.
		ON delay	holds the OFF state of a signal for a certain period of time (turning on an X signal after a predetermined time passed) when an external input has changed from off to on.
		Pulse stretch	holds the state of a signal before change for a certain period of time from the change point (not taking in an external input until a predetermined time passes) when an external input has changed.
	Number of input ON times integration function	Counts how many times the external input changed from off to on. When the number of input ON times alarm detection count is set and the number of input ON times reaches the set count, an alarm is output. The number of input ON times is held even if the input module with diagnostic functions is powered off.	
Event time stamp function	Records the time data when an input has changed.		
Output function	Setting of output mode at error	Sets whether to hold or clear the value that was output just before an error if a CPU stop error occurs.	
	Output delay function ^{*1}	OFF delay	holds the ON state of a signal for a certain period of time (turning off a Y signal after a predetermined time passed) when an output signal from the CPU module has changed from on to off.
		ON delay	holds the OFF state of a signal for a certain period of time (turning on a Y signal after a predetermined time passed) when an output signal from the CPU module has changed from off to on.
	Number of output ON times integration function	Counts how many times the output signal from the CPU module changed from off to on. When the number of output ON times alarm detection count is set and the number of output ON times reaches the set count, an alarm is output. The number of output ON times is held even if the output module with diagnostic functions is powered off.	
Function common to input/output modules	Interrupt function	Executes an interrupt program of the CPU module when an interrupt factor such as an error is detected.	
	LED indication setting on error condition	Sets which indication method the I/O status indicator LED must take when an error has occurred. With this function, the I/O status indicator LED indicates an error occurrence on each I/O terminal.	
Diagnostic function	Input disconnection detection function	Checks whether disconnection has occurred or not when an input device is off. This function can be used by connecting a bleeder resistor (resistance value as a guide: approximately 56kΩ) in parallel near the input device.	
	Output disconnection detection function	Checks whether a load is disconnected or not while the output is off.	
	Output short-circuit detection function	Detects an output overcurrent due to a short circuit while the output is on.	
	Output disconnection detection disable time setting	Disables the disconnection detection function for a predetermined period of time after the turning on of the output. This reduces the false disconnection detection because the result of detection is not affected by the back EMF just after the output ON.	
Inter-module synchronization function		Synchronizes input and output with multiple modules on which the inter-module synchronization function is enabled.  MELSEC iQ-R Inter-Module Synchronization Function Reference Manual	
Error history function		Records up to the 16 errors and alarms that occurred in the I/O module with diagnostic functions to store them into the buffer memory areas.	
Event history function		Collects the errors and alarms that occurred and the operations executed in the I/O module with diagnostic functions as event information into the CPU module.	

Item	Description
Online module change function	Allows addition of a module or replacement of a module mounted on a main base unit or an extension base unit while controlling the system at power-on.  MELSEC iQ-R Online Module Change Manual

*1 This function cannot be used with the inter-module synchronization function. (The settings for the input delay function and output delay function are ignored.)

Point 

When using the inter-module synchronization function, set a value so that the fixed scan interval of the inter-module synchronization is 0.222ms or longer. If a value smaller than 0.222ms is set, the synchronization cycle setting too short error (error code: 1EA0H) occurs.

4 PROCEDURES BEFORE OPERATION

This chapter describes the procedures before operation.

1. Mounting a module

Mount the I/O module with diagnostic functions in any desired configuration.

2. Wiring

Perform wiring of external devices to the I/O module with diagnostic functions.

 Page 27 Wiring

3. Adding a module

Add the I/O module with diagnostic functions to a module configuration by using the engineering tool. For details, refer to the following.

 GX Works3 Operating Manual

4. Module settings

Configure the initial setting of the module, module label setting, and auto refresh setting by using the engineering tool. For details, refer to the following.

 MELSEC iQ-R I/O Module (With Diagnostic Functions) User's Manual (Application)

5. Programming

Create a program. For details, refer to the following.

 GX Works3 Operating Manual

5 INSTALLATION AND WIRING

This chapter describes the installation and wiring of the I/O module with diagnostic functions.

5.1 Before Using the I/O Modules with Diagnostic Functions

Input module with diagnostic functions

Precautions when using the input module with diagnostic functions

■ Measures against back EMF

When connecting an inductive load, connect a diode in parallel with the load. Use the diode that satisfies the following conditions:

- A reverse breakdown voltage is more than ten times as high as the circuit voltage.
- A forward current is more than twice as high as the load current.

Negative common

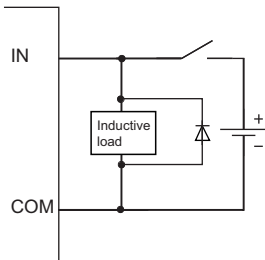

Output module with diagnostic functions

Precautions when using the output module with diagnostic functions

■Maximum switching frequency when L load is driven

The maximum switching frequency imposes a limit on the use; an ON state or an OFF state must not be changed without an interval of at least one second.

■Load to be connected

When connecting a counter or timer utilizing a DC-DC converter as a load of the output module with diagnostic functions, select the output module whose maximum load current is higher than the inrush current of a load to be connected. If the system is designed on the basis of the average current of the load, an inrush current flows cyclically from the load while the output module with diagnostic functions is in an ON state or in operation, which can cause failure of the module. When designing the system on the basis of the average current of the load, take any of the corrective actions below to alleviate the effect of the inrush current.

- Connecting a resistor in series with the load

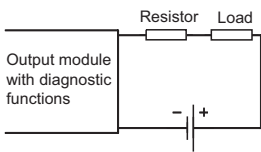

- Connecting an inductor in series with the load

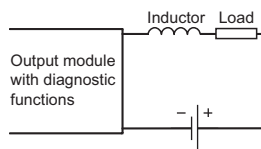

■Measures against reverse current

In the following connections, a reverse current flows to the output element, which can cause failure.

When wiring, set up diodes as the following figures show:

- When connecting transistor output modules in parallel

Source type

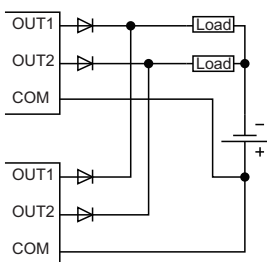

- When providing another circuit in parallel with a transistor output module

Source type

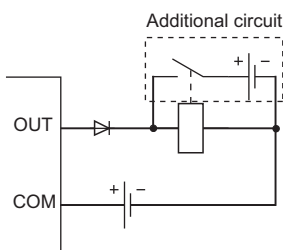

■ Measures against back EMF

When connecting an inductive load, connect a diode in parallel with the load.

Use the diode that satisfies the following conditions:

- A reverse breakdown voltage is more than ten times as high as the circuit voltage.
- A forward current is more than twice as high as the load current.

Source type

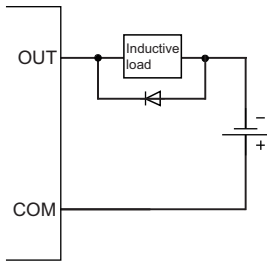

■ About element protection of the output module with diagnostic functions

If excessive noise affects the terminals of the output module with diagnostic functions, the output may be turned on to help the protection of the output element. Adjust the voltage between terminals of the output module with diagnostic functions to fall within the operating load voltage range by taking following measures:

- To use an inductive load such as a relay, a surge suppressor is required on the load side as well. Take appropriate measures with the measures against back EMF as a guide. (☞ Page 26 Measures against back EMF)
- To prevent excessive noise, avoid installing power cables together with I/O cables.

5.2 Wiring

This section describes the wiring of the I/O module with diagnostic functions.

Precautions

- When wiring the terminal block, be sure to use a solderless terminal with a width of 0.8mm or less. In addition, one terminal part allows connection of up to two solderless terminals.
- A solderless terminal with an insulation sleeve cannot be used for the terminal block. To prevent a short-circuit due to a loose terminal block screw, coating the wire connection part of a solderless terminal with a mark tube or insulation tube is recommended.
- For the wire to be connected to the terminal block, use the following.

Applicable wire size	Material	Temperature rating
0.3 to 0.75mm ² (22 to 18 AWG) (stranded wire) Outside diameter: 2.8mm or less ^{*1}	Copper	75°C or higher

- Use the UL listed solderless terminal, R1.25-3.
- Tighten the terminal block screws within the following specified torque range.

Screw	Tightening torque range
Terminal block screw (M3)	0.42 to 0.58N·m
Terminal block mounting screw (M3.5)	0.66 to 0.89N·m

*1 Use the wire of 0.75mm² or smaller. If the wire of larger than 0.75mm² is used, the sideways overhang of wiring becomes large, contacts with the terminal block or connector of an adjacent module, and results in applying stress to the module. Note that the wire of 0.3 to 1.5mm² (22 to 16 AWG) can be used when a spring clamp terminal block (Q6TE-18SN) is used instead. To use a wire of larger size than the one described in the above table, take a measure by using FA goods of Mitsubishi Electric Engineering Co., Ltd. (such as FA-TB161AC+ FA-CBL20D).

Wiring method, installation procedure, and removal procedure of the terminal block

For the wiring method, installation procedure, and removal procedure, refer to the following.

 MELSEC iQ-R Module Configuration Manual

5.3 Input Wiring Examples

The following figures show examples of wiring between the input module with diagnostic functions and connectable DC input devices (DC output type).

The input disconnection detection function detects a disconnection (no connection) when the input current is 0.3mA/point or lower.

- When not using the input disconnection detection function, set "Input disconnection detection setting" to "Not detected" in "Application setting" of the module parameter.
- When using the input disconnection detection function, set "Input disconnection detection setting" to "To detect" in "Application setting" of the module parameter. In addition, when the leakage current of the input device is 0.3mA/point or lower, connect a bleeder resistor (resistance value as a guide: approximately 56k Ω) in parallel near the input device connected.

Wiring example for contact output type

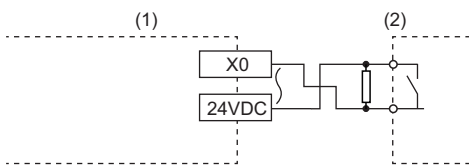

(1): Input module with diagnostic functions
(2): Contact output type

Wiring example for DC 2-wire type

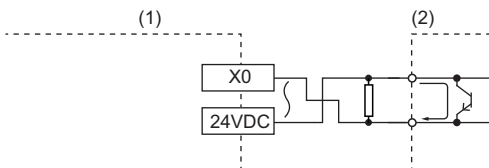

(1): Input module with diagnostic functions
(2): DC 2-wire type

Wiring example for transistor output type

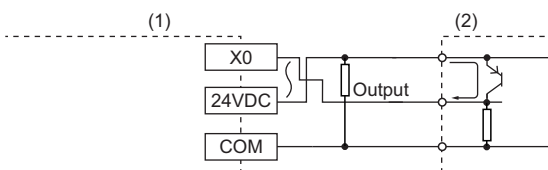

(1): Input module with diagnostic functions
(2): PNP current output type

APPENDICES

Appendix 1 External Dimensions

This chapter shows the external dimensions of the I/O module with diagnostic functions.

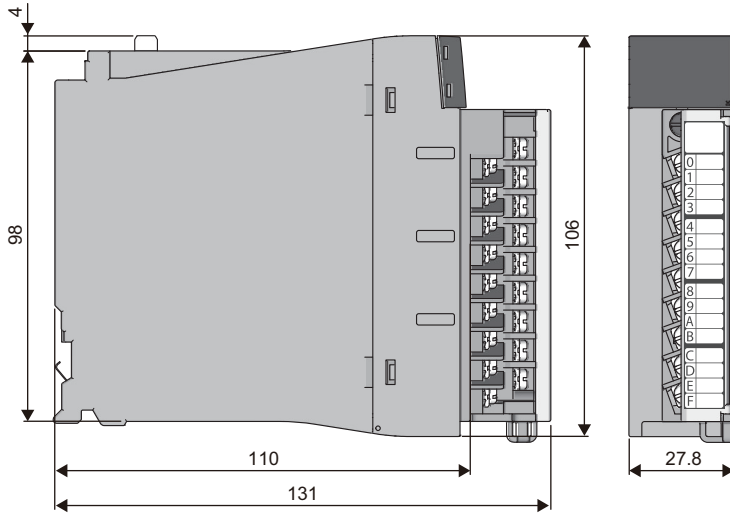

(unit: mm)

MEMO

A

INDEX

A

ALM LED 13

E

ERR LED 13

I

I/O status indicator LED 13

Inter-module synchronization function 20

O

Overheat protection 18

Overload protection 18

R

RUN LED 13

RX40NC6B DC input module 15

RY40PT5B transistor output module 17

MEMO

REVISIONS

*The manual number is given on the bottom left of the back cover.

Revision date	*Manual number	Description
May 2016	SH(NA)-081619ENG-A	First edition

Japanese manual number: SH-081618-A

This manual confers no industrial property rights of any other kind, nor does it confer any patent licenses. Mitsubishi Electric Corporation cannot be held responsible for any problems involving industrial property rights which may occur as a result of using the contents noted in this manual.

© 2016 MITSUBISHI ELECTRIC CORPORATION

WARRANTY

Please confirm the following product warranty details before using this product.

1. Gratis Warranty Term and Gratis Warranty Range

If any faults or defects (hereinafter "Failure") found to be the responsibility of Mitsubishi occurs during use of the product within the gratis warranty term, the product shall be repaired at no cost via the sales representative or Mitsubishi Service Company.

However, if repairs are required onsite at domestic or overseas location, expenses to send an engineer will be solely at the customer's discretion. Mitsubishi shall not be held responsible for any re-commissioning, maintenance, or testing on-site that involves replacement of the failed module.

[Gratis Warranty Term]

The gratis warranty term of the product shall be for one year after the date of purchase or delivery to a designated place. Note that after manufacture and shipment from Mitsubishi, the maximum distribution period shall be six (6) months, and the longest gratis warranty term after manufacturing shall be eighteen (18) months. The gratis warranty term of repair parts shall not exceed the gratis warranty term before repairs.

[Gratis Warranty Range]

- (1) The range shall be limited to normal use within the usage state, usage methods and usage environment, etc., which follow the conditions and precautions, etc., given in the instruction manual, user's manual and caution labels on the product.
- (2) Even within the gratis warranty term, repairs shall be charged for in the following cases.
 1. Failure occurring from inappropriate storage or handling, carelessness or negligence by the user. Failure caused by the user's hardware or software design.
 2. Failure caused by unapproved modifications, etc., to the product by the user.
 3. When the Mitsubishi product is assembled into a user's device, Failure that could have been avoided if functions or structures, judged as necessary in the legal safety measures the user's device is subject to or as necessary by industry standards, had been provided.
 4. Failure that could have been avoided if consumable parts (battery, backlight, fuse, etc.) designated in the instruction manual had been correctly serviced or replaced.
 5. Failure caused by external irresistible forces such as fires or abnormal voltages, and Failure caused by force majeure such as earthquakes, lightning, wind and water damage.
 6. Failure caused by reasons unpredictable by scientific technology standards at time of shipment from Mitsubishi.
 7. Any other failure found not to be the responsibility of Mitsubishi or that admitted not to be so by the user.

2. Onerous repair term after discontinuation of production

- (1) Mitsubishi shall accept onerous product repairs for seven (7) years after production of the product is discontinued. Discontinuation of production shall be notified with Mitsubishi Technical Bulletins, etc.
- (2) Product supply (including repair parts) is not available after production is discontinued.

3. Overseas service

Overseas, repairs shall be accepted by Mitsubishi's local overseas FA Center. Note that the repair conditions at each FA Center may differ.

4. Exclusion of loss in opportunity and secondary loss from warranty liability

Regardless of the gratis warranty term, Mitsubishi shall not be liable for compensation to:

- (1) Damages caused by any cause found not to be the responsibility of Mitsubishi.
- (2) Loss in opportunity, lost profits incurred to the user by Failures of Mitsubishi products.
- (3) Special damages and secondary damages whether foreseeable or not, compensation for accidents, and compensation for damages to products other than Mitsubishi products.
- (4) Replacement by the user, maintenance of on-site equipment, start-up test run and other tasks.

5. Changes in product specifications

The specifications given in the catalogs, manuals or technical documents are subject to change without prior notice.

TRADEMARKS

Ethernet is a registered trademark of Fuji Xerox Corporation in Japan.

The company names, system names and product names mentioned in this manual are either registered trademarks or trademarks of their respective companies.

In some cases, trademark symbols such as [™] or [®] are not specified in this manual.

SH(NA)-081619ENG-A(1605)MEE

MODEL: R-DFIO-U-IN-E

MODEL CODE: 13JX50

mitsubishi electric corporation

HEAD OFFICE : TOKYO BUILDING, 2-7-3 MARUNOUCHI, CHIYODA-KU, TOKYO 100-8310, JAPAN
NAGOYA WORKS : 1-14, YADA-MINAMI 5-CHOME, HIGASHI-KU, NAGOYA, JAPAN

When exported from Japan, this manual does not require application to the
Ministry of Economy, Trade and Industry for service transaction permission.

Specifications subject to change without notice.