



Mitsubishi Programmable Controller

**MELSEC iQ-R**  
series

MELSEC iQ-R High Speed Analog-Digital  
Converter Module  
User's Manual (Startup)

---

-R60ADH4



# SAFETY PRECAUTIONS

---



(Read these precautions before using this product.)

Before using this product, please read this manual and the relevant manuals carefully and pay full attention to safety to handle the product correctly.

The precautions given in this manual are concerned with this product only. For the safety precautions of the programmable controller system, refer to the MELSEC iQ-R Module Configuration Manual.

In this manual, the safety precautions are classified into two levels: "⚠ WARNING" and "⚠ CAUTION".

---

 <b>WARNING</b>	Indicates that incorrect handling may cause hazardous conditions, resulting in death or severe injury.
 <b>CAUTION</b>	Indicates that incorrect handling may cause hazardous conditions, resulting in minor or moderate injury or property damage.

---

Under some circumstances, failure to observe the precautions given under "⚠ CAUTION" may lead to serious consequences.

Observe the precautions of both levels because they are important for personal and system safety.

Make sure that the end users read this manual and then keep the manual in a safe place for future reference.

## [Design Precautions]

---

### **WARNING**

---

- Configure safety circuits external to the programmable controller to ensure that the entire system operates safely even when a fault occurs in the external power supply or the programmable controller. Failure to do so may result in an accident due to an incorrect output or malfunction.
    - (1) Emergency stop circuits, protection circuits, and protective interlock circuits for conflicting operations (such as forward/reverse rotations or upper/lower limit positioning) must be configured external to the programmable controller.
    - (2) When the programmable controller detects an abnormal condition, it stops the operation and all outputs are:
      - Turned off if the overcurrent or overvoltage protection of the power supply module is activated.
      - Held or turned off according to the parameter setting if the self-diagnostic function of the CPU module detects an error such as a watchdog timer error.
    - (3) All outputs may be turned on if an error occurs in a part, such as an I/O control part, where the CPU module cannot detect any error. To ensure safety operation in such a case, provide a safety mechanism or a fail-safe circuit external to the programmable controller. For a fail-safe circuit example, refer to "General Safety Requirements" in the MELSEC iQ-R Module Configuration Manual.
    - (4) Outputs may remain on or off due to a failure of a component such as a relay and transistor in an output circuit. Configure an external circuit for monitoring output signals that could cause a serious accident.
  - In an output circuit, when a load current exceeding the rated current or an overcurrent caused by a load short-circuit flows for a long time, it may cause smoke and fire. To prevent this, configure an external safety circuit, such as a fuse.
  - Configure a circuit so that the programmable controller is turned on first and then the external power supply. If the external power supply is turned on first, an accident may occur due to an incorrect output or malfunction.
  - For the operating status of each station after a communication failure, refer to manuals relevant to the network. Incorrect output or malfunction due to a communication failure may result in an accident.
-

## [Design Precautions]

---

### **WARNING**

- When connecting an external device with a CPU module or intelligent function module to modify data of a running programmable controller, configure an interlock circuit in the program to ensure that the entire system will always operate safely. For other forms of control (such as program modification, parameter change, forced output, or operating status change) of a running programmable controller, read the relevant manuals carefully and ensure that the operation is safe before proceeding. Improper operation may damage machines or cause accidents.
  - Especially, when a remote programmable controller is controlled by an external device, immediate action cannot be taken if a problem occurs in the programmable controller due to a communication failure. To prevent this, configure an interlock circuit in the program, and determine corrective actions to be taken between the external device and CPU module in case of a communication failure.
  - Do not write any data to the "system area" and "write-protect area" of the buffer memory in the module. Also, do not use any "use prohibited" signals as an output signal from the CPU module to each module. Doing so may cause malfunction of the programmable controller system. For the "system area", "write-protect area", and the "use prohibited" signals, refer to the user's manual for the module used.
  - If a communication cable is disconnected, the network may be unstable, resulting in a communication failure of multiple stations. Configure an interlock circuit in the program to ensure that the entire system will always operate safely even if communications fail. Failure to do so may result in an accident due to an incorrect output or malfunction.
  - To maintain the safety of the programmable controller system against unauthorized access from external devices via the network, take appropriate measures. To maintain the safety against unauthorized access via the Internet, take measures such as installing a firewall.
- 

## [Design Precautions]

---

### **CAUTION**

- Do not install the control lines or communication cables together with the main circuit lines or power cables. Keep a distance of 100mm or more between them. Failure to do so may result in malfunction due to noise.
  - During control of an inductive load such as a lamp, heater, or solenoid valve, a large current (approximately ten times greater than normal) may flow when the output is turned from off to on. Therefore, use a module that has a sufficient current rating.
  - After the CPU module is powered on or is reset, the time taken to enter the RUN status varies depending on the system configuration, parameter settings, and/or program size. Design circuits so that the entire system will always operate safely, regardless of the time.
  - Do not power off the programmable controller or reset the CPU module while the settings are being written. Doing so will make the data in the flash ROM undefined. The values need to be set in the buffer memory and written to the flash ROM again. Doing so also may cause malfunction or failure of the module.
  - When changing the operating status of the CPU module from external devices (such as the remote RUN/STOP functions), select "Do Not OPEN in Program" for "Open Method Setting" in the module parameters. If "OPEN in Program" is selected, an execution of the remote STOP function causes the communication line to close. Consequently, the CPU module cannot reopen the line, and external devices cannot execute the remote RUN function.
-

## [Installation Precautions]

---

### **WARNING**

- Shut off the external power supply (all phases) used in the system before mounting or removing the module. Failure to do so may result in electric shock or cause the module to fail or malfunction.
- 

## [Installation Precautions]

---

### **CAUTION**

- Use the programmable controller in an environment that meets the general specifications in the Safety Guidelines included with the base unit. Failure to do so may result in electric shock, fire, malfunction, or damage to or deterioration of the product.
  - To mount a module, place the concave part(s) located at the bottom onto the guide(s) of the base unit, and push in the module until the hook(s) located at the top snaps into place. Incorrect interconnection may cause malfunction, failure, or drop of the module.
  - When using the programmable controller in an environment of frequent vibrations, fix the module with a screw.
  - Tighten the screws within the specified torque range. Undertightening can cause drop of the screw, short circuit, or malfunction. Overtightening can damage the screw and/or module, resulting in drop, short circuit, or malfunction.
  - When using an extension cable, connect it to the extension cable connector of the base unit securely. Check the connection for looseness. Poor contact may cause malfunction.
  - When using an SD memory card, fully insert it into the SD memory card slot. Check that it is inserted completely. Poor contact may cause malfunction.
  - Securely insert an extended SRAM cassette into the cassette connector of the CPU module. After insertion, close the cassette cover and check that the cassette is inserted completely. Poor contact may cause malfunction.
  - Do not directly touch any conductive parts and electronic components of the module, SD memory card, extended SRAM cassette, or connector. Doing so can cause malfunction or failure of the module.
- 

## [Wiring Precautions]

---

### **WARNING**

- Shut off the external power supply (all phases) used in the system before installation and wiring. Failure to do so may result in electric shock or cause the module to fail or malfunction.
  - After installation and wiring, attach the included terminal cover to the module before turning it on for operation. Failure to do so may result in electric shock.
-

## [Wiring Precautions]

---

### CAUTION

- Individually ground the FG and LG terminals of the programmable controller with a ground resistance of 100 ohms or less. Failure to do so may result in electric shock or malfunction.
  - Use applicable solderless terminals and tighten them within the specified torque range. If any spade solderless terminal is used, it may be disconnected when the terminal screw comes loose, resulting in failure.
  - Check the rated voltage and signal layout before wiring to the module, and connect the cables correctly. Connecting a power supply with a different voltage rating or incorrect wiring may cause fire or failure.
  - Connectors for external devices must be crimped or pressed with the tool specified by the manufacturer, or must be correctly soldered. Incomplete connections may cause short circuit, fire, or malfunction.
  - Securely connect the connector to the module. Poor contact may cause malfunction.
  - Do not install the control lines or communication cables together with the main circuit lines or power cables. Keep a distance of 100mm or more between them. Failure to do so may result in malfunction due to noise.
  - Place the cables in a duct or clamp them. If not, dangling cable may swing or inadvertently be pulled, resulting in damage to the module or cables or malfunction due to poor contact. Do not clamp the extension cables with the jacket stripped.
  - Check the interface type and correctly connect the cable. Incorrect wiring (connecting the cable to an incorrect interface) may cause failure of the module and external device.
  - Tighten the terminal screws or connector screws within the specified torque range. Undertightening can cause drop of the screw, short circuit, fire, or malfunction. Overtightening can damage the screw and/or module, resulting in drop, short circuit, fire, or malfunction.
  - When disconnecting the cable from the module, do not pull the cable by the cable part. For the cable with connector, hold the connector part of the cable. For the cable connected to the terminal block, loosen the terminal screw. Pulling the cable connected to the module may result in malfunction or damage to the module or cable.
  - Prevent foreign matter such as dust or wire chips from entering the module. Such foreign matter can cause a fire, failure, or malfunction.
  - A protective film is attached to the top of the module to prevent foreign matter, such as wire chips, from entering the module during wiring. Do not remove the film during wiring. Remove it for heat dissipation before system operation.
  - Programmable controllers must be installed in control panels. Connect the main power supply to the power supply module in the control panel through a relay terminal block. Wiring and replacement of a power supply module must be performed by qualified maintenance personnel with knowledge of protection against electric shock. For wiring, refer to the MELSEC iQ-R Module Configuration Manual.
  - For Ethernet cables to be used in the system, select the ones that meet the specifications in the user's manual for the module used. If not, normal data transmission is not guaranteed.
-

## [Startup and Maintenance Precautions]

---

### **WARNING**

---

- Do not touch any terminal while power is on. Doing so will cause electric shock or malfunction.
  - Correctly connect the battery connector. Do not charge, disassemble, heat, short-circuit, solder, or throw the battery into the fire. Also, do not expose it to liquid or strong shock. Doing so will cause the battery to produce heat, explode, ignite, or leak, resulting in injury and fire.
  - Shut off the external power supply (all phases) used in the system before cleaning the module or retightening the terminal screws, connector screws, or module fixing screws. Failure to do so may result in electric shock.
-



## [Startup and Maintenance Precautions]

---

### **CAUTION**

- When connecting an external device with a CPU module or intelligent function module to modify data of a running programmable controller, configure an interlock circuit in the program to ensure that the entire system will always operate safely. For other forms of control (such as program modification, parameter change, forced output, or operating status change) of a running programmable controller, read the relevant manuals carefully and ensure that the operation is safe before proceeding. Improper operation may damage machines or cause accidents.
  - Especially, when a remote programmable controller is controlled by an external device, immediate action cannot be taken if a problem occurs in the programmable controller due to a communication failure. To prevent this, configure an interlock circuit in the program, and determine corrective actions to be taken between the external device and CPU module in case of a communication failure.
  - Do not disassemble or modify the modules. Doing so may cause failure, malfunction, injury, or a fire.
  - Use any radio communication device such as a cellular phone or PHS (Personal Handy-phone System) more than 25cm away in all directions from the programmable controller. Failure to do so may cause malfunction.
  - Shut off the external power supply (all phases) used in the system before mounting or removing the module. Failure to do so may cause the module to fail or malfunction.
  - Tighten the screws within the specified torque range. Undertightening can cause drop of the component or wire, short circuit, or malfunction. Overtightening can damage the screw and/or module, resulting in drop, short circuit, or malfunction.
  - After the first use of the product, do not mount/remove the module to/from the base unit, and the terminal block to/from the module, and do not insert/remove the extended SRAM cassette to/from the CPU module more than 50 times (IEC 61131-2 compliant) respectively. Exceeding the limit may cause malfunction.
  - After the first use of the product, do not insert/remove the SD memory card to/from the CPU module more than 500 times. Exceeding the limit may cause malfunction.
  - Do not touch the metal terminals on the back side of the SD memory card. Doing so may cause malfunction or failure.
  - Do not touch the integrated circuits on the circuit board of an extended SRAM cassette. Doing so may cause malfunction or failure of the module.
  - Do not drop or apply shock to the battery to be installed in the module. Doing so may damage the battery, causing the battery fluid to leak inside the battery. If the battery is dropped or any shock is applied to it, dispose of it without using.
  - Startup and maintenance of a control panel must be performed by qualified maintenance personnel with knowledge of protection against electric shock. Lock the control panel so that only qualified maintenance personnel can operate it.
  - Before handling the module, touch a conducting object such as a grounded metal to discharge the static electricity from the human body. Failure to do so may cause the module to fail or malfunction.
-

## [Operating Precautions]

---

### CAUTION

- When changing data and operating status, and modifying program of the running programmable controller from an external device such as a personal computer connected to an intelligent function module, read relevant manuals carefully and ensure the safety before operation. Incorrect change or modification may cause system malfunction, damage to the machines, or accidents.
  - Do not power off the programmable controller or reset the CPU module while the setting values in the buffer memory are being written to the flash ROM in the module. Doing so will make the data in the flash ROM undefined. The values need to be set in the buffer memory and written to the flash ROM again. Doing so can cause malfunction or failure of the module.
- 

## [Disposal Precautions]

---

### CAUTION

- When disposing of this product, treat it as industrial waste.
  - When disposing of batteries, separate them from other wastes according to the local regulations. For details on battery regulations in EU member states, refer to the MELSEC iQ-R Module Configuration Manual.
- 

## [Transportation Precautions]

---

### CAUTION

- When transporting lithium batteries, follow the transportation regulations. For details on the regulated models, refer to the MELSEC iQ-R Module Configuration Manual.
  - The halogens (such as fluorine, chlorine, bromine, and iodine), which are contained in a fumigant used for disinfection and pest control of wood packaging materials, may cause failure of the product. Prevent the entry of fumigant residues into the product or consider other methods (such as heat treatment) instead of fumigation. The disinfection and pest control measures must be applied to unprocessed raw wood.
-

# CONDITIONS OF USE FOR THE PRODUCT

---

(1) Mitsubishi programmable controller ("the PRODUCT") shall be used in conditions;

- i) where any problem, fault or failure occurring in the PRODUCT, if any, shall not lead to any major or serious accident; and
- ii) where the backup and fail-safe function are systematically or automatically provided outside of the PRODUCT for the case of any problem, fault or failure occurring in the PRODUCT.

(2) The PRODUCT has been designed and manufactured for the purpose of being used in general industries.

MITSUBISHI SHALL HAVE NO RESPONSIBILITY OR LIABILITY (INCLUDING, BUT NOT LIMITED TO ANY AND ALL RESPONSIBILITY OR LIABILITY BASED ON CONTRACT, WARRANTY, TORT, PRODUCT LIABILITY) FOR ANY INJURY OR DEATH TO PERSONS OR LOSS OR DAMAGE TO PROPERTY CAUSED BY the PRODUCT THAT ARE OPERATED OR USED IN APPLICATION NOT INTENDED OR EXCLUDED BY INSTRUCTIONS, PRECAUTIONS, OR WARNING CONTAINED IN MITSUBISHI'S USER, INSTRUCTION AND/OR SAFETY MANUALS, TECHNICAL BULLETINS AND GUIDELINES FOR the PRODUCT.

("Prohibited Application")

Prohibited Applications include, but not limited to, the use of the PRODUCT in;

- Nuclear Power Plants and any other power plants operated by Power companies, and/or any other cases in which the public could be affected if any problem or fault occurs in the PRODUCT.
- Railway companies or Public service purposes, and/or any other cases in which establishment of a special quality assurance system is required by the Purchaser or End User.
- Aircraft or Aerospace, Medical applications, Train equipment, transport equipment such as Elevator and Escalator, Incineration and Fuel devices, Vehicles, Manned transportation, Equipment for Recreation and Amusement, and Safety devices, handling of Nuclear or Hazardous Materials or Chemicals, Mining and Drilling, and/or other applications where there is a significant risk of injury to the public or property.

Notwithstanding the above, restrictions Mitsubishi may in its sole discretion, authorize use of the PRODUCT in one or more of the Prohibited Applications, provided that the usage of the PRODUCT is limited only for the specific applications agreed to by Mitsubishi and provided further that no special quality assurance or fail-safe, redundant or other safety features which exceed the general specifications of the PRODUCTS are required. For details, please contact the Mitsubishi representative in your region.

## INTRODUCTION

---

Thank you for purchasing the Mitsubishi MELSEC iQ-R series programmable controllers.

This manual describes the specifications, procedures before operation, wiring, and programming of the relevant product listed below.

Before using this product, please read this manual and the relevant manuals carefully and develop familiarity with the functions and performance of the MELSEC iQ-R series programmable controller to handle the product correctly.

When applying the program examples provided in this manual to an actual system, ensure the applicability and confirm that it will not cause system control problems.

Please make sure that the end users read this manual.



---

Unless otherwise specified, this manual provides program examples in which the I/O numbers of X/Y0 to X/YF are assigned to the A/D converter module. Assign I/O numbers when applying the program examples to an actual system. For I/O number assignment, refer to the following.

MELSEC iQ-R Module Configuration Manual

---

### Relevant product



R60ADH4

# COMPLIANCE WITH EMC AND LOW VOLTAGE DIRECTIVES

---

## Method of ensuring compliance



To ensure that Mitsubishi programmable controllers maintain EMC and Low Voltage Directives when incorporated into other machinery or equipment, certain measures may be necessary. Please refer to one of the following manuals.

-  MELSEC iQ-R Module Configuration Manual
-  Safety Guidelines (This manual is included with the base unit.)

The CE mark on the side of the programmable controller indicates compliance with EMC and Low Voltage Directives.

## Additional measures

To ensure that this product maintains EMC and Low Voltage Directives, please refer to one of the following manuals.

-  MELSEC iQ-R Module Configuration Manual
-  Safety Guidelines (This manual is included with the base unit.)

# CONTENTS

SAFETY PRECAUTIONS .....	1
CONDITIONS OF USE FOR THE PRODUCT .....	9
INTRODUCTION .....	9
COMPLIANCE WITH EMC AND LOW VOLTAGE DIRECTIVES .....	10
RELEVANT MANUALS .....	12
TERMS .....	13
MANUAL PAGE ORGANIZATION .....	14
<b>CHAPTER 1 PART NAMES</b>	<b>15</b>
<b>CHAPTER 2 SPECIFICATIONS</b>	<b>17</b>
2.1 Performance Specifications .....	17
<b>CHAPTER 3 FUNCTION LIST</b>	<b>19</b>
<b>CHAPTER 4 PROCEDURES BEFORE OPERATION</b>	<b>22</b>
<b>CHAPTER 5 WIRING</b>	<b>24</b>
5.1 Terminal Block .....	24
5.2 External Wiring .....	26
<b>CHAPTER 6 OPERATION EXAMPLES</b>	<b>28</b>
6.1 Programming Procedure .....	28
6.2 Program Examples .....	29
<b>CHAPTER 7 OFFSET/GAIN SETTING</b>	<b>35</b>
7.1 Setting Procedure .....	35
<b>APPENDICES</b>	<b>38</b>
Appendix 1 I/O Conversion Characteristics .....	38
Appendix 2 Accuracy .....	41
Appendix 3 Input Response Time .....	42
Appendix 4 External Dimensions .....	43
<b>INDEX</b>	<b>44</b>
REVISIONS .....	46
WARRANTY .....	47
TRADEMARKS .....	48

# RELEVANT MANUALS

Manual name [manual number]	Description	Available form
MELSEC iQ-R High Speed Analog-Digital Converter Module User's Manual (Startup) [SH-081580ENG] (this manual)	System configuration, specifications, procedures before operation, wiring, and operation examples of the high speed analog-digital converter module	Print book e-Manual PDF
MELSEC iQ-R High Speed Analog-Digital Converter Module User's Manual (Application) [SH-081581ENG]	Functions, parameter settings, I/O signals, buffer memory, and troubleshooting of the high speed analog-digital converter module	Print book e-Manual PDF
MELSEC iQ-R Programming Manual (Instructions, Standard Functions/Function Blocks) [SH-081266ENG]	Instructions for the CPU module, dedicated instructions for the intelligent function modules, and standard functions/function blocks	e-Manual PDF

This manual does not include detailed information on the following:

- General specifications
- Applicable CPU modules and the number of mountable modules
- Installation

For details, refer to the following.

 MELSEC iQ-R Module Configuration Manual

This manual does not include information on the module function blocks.

For details, refer to the Function Block Reference for the module used.

## Point

e-Manual refers to the Mitsubishi FA electronic book manuals that can be browsed using a dedicated tool.

e-Manual has the following features:

- Required information can be cross-searched in multiple manuals.
- Other manuals can be accessed from the links in the manual.
- The hardware specifications of each part can be found from the product figures.
- Pages that users often browse can be bookmarked.

# TERMS

Unless otherwise specified, this manual uses the following terms.

Term	Description
A/D converter module	The abbreviation for the MELSEC iQ-R series high speed analog-digital converter module
Buffer memory	A memory in an intelligent function module for storing data (such as setting values and monitored values) to be transferred to the CPU module
Engineering tool	Another term for GX Works3
Factory default setting	A generic term for analog input ranges of 0 to 10V, 0 to 5V, 1 to 5V, -10 to 10V, 0 to 20mA, 4 to 20mA, 1 to 5V (extended mode), and 4 to 20mA (extended mode). The ranges of 4 to 20mA (extended mode) and 1 to 5V (extended mode) are displayed in the window of the engineering tool as follows. <ul style="list-style-type: none"><li>• 4 to 20mA (Extension)</li><li>• 1 to 5V (Extension)</li></ul>
Global label	A label that is valid for all the program data when multiple program data are created in the project. The global label has two types: a module specific label (module label), which is generated automatically by GX Works3, and an optional label, which can be created for any specified device.
GX Works3	The product name of the software package for the MELSEC programmable controllers
Module label	A label that represents one of memory areas (I/O signals and buffer memory areas) specific to each module in a given character string. For the module used, GX Works3 automatically generates this label, which can be used as a global label.
Normal mode	This mode is for normal A/D conversion. There are two types: Normal mode (medium speed: 10 $\mu$ s/CH) and normal mode (low speed: 20 $\mu$ s/CH).
Offset/gain setting mode	This mode is for configuring the offset/gain setting.
User range	An analog input range where any value can be set. This range can be set in the offset/gain setting.
Watchdog timer error	An error that occurs if the internal processing of the A/D converter module is abnormal. Watchdog timer enables the module to monitor its own internal processing.

# MANUAL PAGE ORGANIZATION

In this manual, pages about functions, I/O signals, and buffer memory areas are organized and the symbols are used as shown below.

The following illustration is for explanation purpose only, and should not be referred to as an actual documentation.

## Averaging processing

Common

The averaging processing is performed to the digital output value for each channel. The value after the averaging processing is performed is stored to the buffer memory area.

The following three types of averaging processing are provided.

- Time average
- Count average
- Moving average

### Time average

Medium speed
Low speed

The A/D conversion is performed for the setting time and the averaging processing is performed to the total value except the maximum and minimum values. The value after the averaging processing is stored to the buffer memory area.

■Setting time  
The setting range of the time (for averaging) is 1 to 5000ms.

■Processing times  
The number of processing times within the setting time changes depending on the number of channels where the A/D conversion is enabled.

- Number of processing times (times) = Setting time/Sampling cycle

**Ex.**  
The following table shows the processing times with the setting below.

Item	Setting
Operation mode	Normal mode (medium speed: 10µs/CH)
Number of channels where the A/D conversion is enabled	Four channels (CH1 to CH4)
Setting time	5ms

$8(\text{ms}) / (4 (\text{CH}) \times 0.01(\text{ms})) = 200 (\text{times})$   
Conversion is processed 200 times and the mean value is output.

### Count average

Medium speed
Low speed

The A/D conversion is performed for the set number of times and the averaging processing is performed to the total value except the maximum and minimum values. The value after the averaging processing is stored to the buffer memory area.

The time taken for the mean value calculated through the average processing to be stored in the buffer memory area changes depending on the number of channels where the A/D conversion is enabled.

- Processing time = Set number of times × Sampling cycle

**Ex.**  
The following table shows the processing time with the setting below.

Item	Setting
Operation mode	Normal mode (medium speed: 10µs/CH)
Number of channels where the A/D conversion is enabled	Four channels (CH1 to CH4)
Set number of times	Five times

$5 (\text{times}) \times (4 (\text{CH})) \times 10 (\mu\text{s}) = 200 (\mu\text{s})$   
A mean value is output every 200µs.

1 FUNCTIONS  
 1.5 A/D Conversion Method **24**

① The following table lists the operation modes of the A/D converter module in which the corresponding functions and buffer memory areas can be used. Each icon indicates an operation mode as follows.

Icon	Description
<div style="border: 1px solid black; border-radius: 10px; padding: 5px; width: fit-content; margin: 0 auto;">Common</div>	The corresponding functions and buffer memory areas can be used in all the operation modes.
<div style="border: 1px solid black; border-radius: 10px; padding: 5px; width: fit-content; margin: 0 auto;">Medium speed</div>	The corresponding functions and buffer memory areas can be used in the normal mode (medium speed: 10µs/CH).
<div style="border: 1px solid black; border-radius: 10px; padding: 5px; width: fit-content; margin: 0 auto;">Low speed</div>	The corresponding functions and buffer memory areas can be used in the normal mode (low speed: 20µs/CH).
<div style="border: 1px solid black; border-radius: 10px; padding: 5px; width: fit-content; margin: 0 auto;">Simultaneous conversion</div>	The corresponding functions and buffer memory areas can be used in the simultaneous conversion mode (5µs/4CH).
<div style="border: 1px solid black; border-radius: 10px; padding: 5px; width: fit-content; margin: 0 auto;">Synchronization</div>	The corresponding functions and buffer memory areas can be used in the inter-module synchronization mode.

For details on each mode, refer to the following.

MELSEC iQ-R High Speed Analog-Digital Converter Module User's Manual (Application)



# 1 PART NAMES

This chapter describes the part names of the A/D converter module.

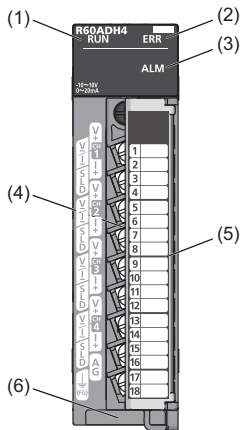

No.	Name	Description
(1)	RUN LED	Indicates the operating status of the module. On: Normal operation Flashing (1s cycles): In offset/gain setting mode Flashing (400ms cycles): Selected as a module for the online module change Off: 5V power supply interrupted, watchdog timer error occurred, or module replacement allowed in the process of the online module change
(2)	ERR LED	Indicates the error status of the module.*1 On: Error occurred Off: Normal operation
(3)	ALM LED	Indicates the alarm status of the module.*1 On: Warning (process alarm or rate alarm) issued Flashing: Input signal error detected Off: Normal operation
(4)	Terminal block	18-point screw terminal block for connecting input signal wires of external devices and others
(5)	Terminal block cover	Covers for preventing electric shock while the power is on
(6)	Production information marking	Shows the production information (16 digits) of the module.

\*1 For details, refer to the following.

📖 MELSEC iQ-R High Speed Analog-Digital Converter Module User's Manual (Application)

# MEMO

---

# 2 SPECIFICATIONS

This chapter describes the performance specifications.

## 2.1 Performance Specifications

This section describes the performance specifications of the A/D converter module.

Item		Specifications																															
Number of analog input channels		4 channels																															
Analog input	Voltage	-10 to 10VDC (input resistance: 1MΩ)																															
	Current	0 to 20mADC (input resistance: 250Ω)																															
Digital output		16-bit signed binary value (-32768 to 32767)																															
I/O characteristics, resolution*1		<table border="1"> <thead> <tr> <th>Analog input range</th> <th>Digital output value</th> <th>Resolution</th> </tr> </thead> <tbody> <tr> <td rowspan="6">Voltage</td> <td>0 to 10V</td> <td rowspan="3">0 to 32000</td> <td>312.5μV</td> </tr> <tr> <td>0 to 5V</td> <td>156.3μV</td> </tr> <tr> <td>1 to 5V</td> <td>125.0μV</td> </tr> <tr> <td>1 to 5V (extended mode)</td> <td>-8000 to 32000</td> <td>125.0μV</td> </tr> <tr> <td>-10 to 10V</td> <td rowspan="2">-32000 to 32000</td> <td>312.5μV</td> </tr> <tr> <td>User range setting</td> <td>125.0μV<sup>*2</sup></td> </tr> <tr> <td rowspan="5">Current</td> <td>0 to 20mA</td> <td rowspan="2">0 to 32000</td> <td>625.0nA</td> </tr> <tr> <td>4 to 20mA</td> <td>500.0nA</td> </tr> <tr> <td>4 to 20mA (extended mode)</td> <td>-8000 to 32000</td> <td>500.0nA</td> </tr> <tr> <td>User range setting</td> <td>-32000 to 32000</td> <td>500.0nA<sup>*2</sup></td> </tr> </tbody> </table>	Analog input range	Digital output value	Resolution	Voltage	0 to 10V	0 to 32000	312.5μV	0 to 5V	156.3μV	1 to 5V	125.0μV	1 to 5V (extended mode)	-8000 to 32000	125.0μV	-10 to 10V	-32000 to 32000	312.5μV	User range setting	125.0μV <sup>*2</sup>	Current	0 to 20mA	0 to 32000	625.0nA	4 to 20mA	500.0nA	4 to 20mA (extended mode)	-8000 to 32000	500.0nA	User range setting	-32000 to 32000	500.0nA <sup>*2</sup>
Analog input range	Digital output value	Resolution																															
Voltage	0 to 10V	0 to 32000	312.5μV																														
	0 to 5V		156.3μV																														
	1 to 5V		125.0μV																														
	1 to 5V (extended mode)	-8000 to 32000	125.0μV																														
	-10 to 10V	-32000 to 32000	312.5μV																														
	User range setting		125.0μV <sup>*2</sup>																														
Current	0 to 20mA	0 to 32000	625.0nA																														
	4 to 20mA		500.0nA																														
	4 to 20mA (extended mode)	-8000 to 32000	500.0nA																														
	User range setting	-32000 to 32000	500.0nA <sup>*2</sup>																														
	Accuracy (accuracy of the maximum digital output value) <sup>*3</sup>	Ambient temperature 25±5°C	Within ±0.1% (±32 digit)																														
Ambient temperature 0 to 55°C		Within ±0.2% (±64 digit)																															
Operation mode (sampling cycle) <sup>*4</sup>		Normal mode (medium speed: 10μs/CH) Normal mode (low speed: 20μs/CH) Simultaneous conversion mode (5μs/4CH)																															
Input band <sup>*5</sup>		40kHz (Normal mode (medium speed: 10μs/CH)) 20kHz (Normal mode (low speed: 20μs/CH)) 60kHz (Simultaneous conversion mode (5μs/4CH))																															
Input response time <sup>*6</sup>		20μs maximum																															
Absolute maximum input <sup>*7</sup>		Voltage: ±15V, Current: 30mA																															
Number of offset/gain settings <sup>*8</sup>		10000 times maximum																															
Isolation method		Between I/O terminals and programmable controller power supply: Photocoupler Between input channels: Non-isolation																															
Withstand voltage		Between I/O terminals and programmable controller power supply: 500VACrms for 1 minute																															
Isolation resistance		Between I/O terminals and programmable controller power supply: 10MΩ or higher, at 500VDC																															
Number of occupied I/O points		16 points (I/O assignment: Intelligent 16 points)																															
External interface		18-point terminal block																															
Applicable wire size		0.3 to 0.75mm <sup>2</sup> (22 to 18 AWG)																															
Applicable solderless terminal		R1.25-3 (solderless terminal with an insulation sleeve cannot be used)																															
Internal current consumption (5VDC)		0.73A																															
External dimensions	Height	106mm (base unit mounting side: 98mm)																															
	Width	27.8mm																															
	Depth	131mm																															
Weight		0.20kg																															

\*1 For details on the I/O conversion characteristics, refer to the following.

☞ Page 38 I/O Conversion Characteristics

\*2 Maximum resolution in the user range setting.

\*3 Except for the conditions under noise influence.

- \*4 The module becomes more susceptible to noise while operating in the operation mode with faster sampling cycle. For measures to reduce noise, refer to the MELSEC iQ-R Module Configuration Manual. If the module is still affected by noise after the measures have been taken, use averaging processing, primary delay filter, and digital filter. For how to use them, refer to the MELSEC iQ-R High Speed Analog-Digital Converter Module User's Manual (Application).
- \*5 The frequency where the amplitude ratio is -3dB when the sine wave with the amplitude of 5V is input.
- \*6 The time until an analog input signal reaches the A/D converter in the A/D converter module.
- \*7 This current value is an instantaneous value at which no breakdown occurs in the internal resistance of the module.
- \*8 A count more than 10000 times causes Number of writes to offset/gain settings reach limit error (error code: 1080H).

# 3 FUNCTION LIST

The following table lists the functions of the A/D converter module. For details on the functions, refer to the following.  
 MELSEC iQ-R High Speed Analog-Digital Converter Module User's Manual (Application)

Item		Description	
Range switching function		Allows switching the input range of an analog input for each channel. Switching the range makes it possible to change the I/O conversion characteristics.	
A/D conversion enable/disable setting function		Controls whether to enable or disable the A/D conversion for each channel.	
A/D conversion method	Sampling processing	Converts an analog input value every sampling cycle and stores it as a digital output value in the buffer memory area. The conversion is performed every 5 $\mu$ s (fixed) in the simultaneous conversion mode, or performed every inter-module synchronization cycle in the inter-module synchronization mode.	
	Averaging processing	Time average	Executes A/D conversion for a set time, and averages the total value excluding the maximum value and the minimum value. The average value is stored in the buffer memory area. The number of processing times within the set time changes depending on the number of channels where the A/D conversion is enabled.
		Count average	Executes A/D conversion for a set number of times, and averages the total value excluding the maximum value and the minimum value. The average value is stored in the buffer memory area. The time taken to store the average value obtained by the average processing in the buffer memory area changes depending on the number of channels where the A/D conversion is enabled.
		Moving average	Averages digital output values taken every sampling cycle for a specified number of times, and stores the average value in the buffer memory area. Because the target range for averaging processing is moved in response to every sampling processing, the latest digital output value can be obtained.
	Primary delay filter		Smooths the transient noise of analog input depending on the set time constant. The smoothed digital output value is stored in the buffer memory area.
	Digital filter	Low pass filter	Removes the unnecessary high-frequency components in a signal, and stores a digital output value in the buffer memory area.
		High pass filter	Removes the unnecessary low-frequency components in a signal, and stores a digital output value in the buffer memory area.
Band pass filter		Passes only necessary frequency in a signal removing other unnecessary frequencies, and stores a digital output value in the buffer memory area.	
Scaling function		Performs scale conversion on digital output values within a specified range between a scaling upper limit value and a scaling lower limit value. This function reduces the time and effort to create a program of the scale conversion.	
Shift function		Adds (shifts) a set conversion value shift amount to a digital output value and stores the result in the buffer memory area. The change in the conversion value shift amount is reflected to the digital operation value on a real-time basis. Therefore, fine adjustment can be easily performed when the system starts.	
Digital clipping function		Fixes a possible digital operation value to the maximum digital output value or the minimum digital output value when an input current or voltage exceeds the input range.	
Difference conversion function		Subtracts a difference conversion reference value from a digital operation value and stores the acquired value in the buffer memory area.	
Maximum value/minimum value hold function		Stores the maximum and minimum values of digital operation values to the buffer memory area for each channel.	
Warning output function	Process alarm	Outputs a warning when a digital operation value enters the preset warning output range.	
	Rate alarm	Outputs a warning when the change rate of a digital output value is equal to or larger than the rate alarm upper limit value, or the rate is equal to or smaller than the rate alarm lower limit value.	
Input signal error detection function		Detects an analog input value that is above or below the set range.	

Item		Description
Logging function	Normal logging function	Logs (records) up to 90000 digital output values or digital operation values. Logging can be performed under various conditions with the logging hold, level trigger, or logging read function.
	Continuous logging function	Logs digital output values in four channels simultaneously and transfers the logging data to the CPU module continuously without stopping the logging operation. The data that have been converted from analog to digital at high speed (5μs cycle at a maximum) and in four channels simultaneously can be continuously collected. This enables the module to collect data for signal analysis under the condition that the module is connected to sensors having input characteristics of the high-frequency band.
Inter-module synchronization function		Allows the A/D conversion values to be held simultaneously among multiple modules in which the inter-module synchronization function is active.
Interrupt function		Executes an interrupt program of the CPU module when an interrupt factor such as an input signal error or warning output is detected.
Error history function		Records up to the 16 errors and alarms that occurred in the A/D converter module to store them into the buffer memory areas.
Event history function		Collects the errors and alarms that occurred and the operations executed in the A/D converter module as event information into the CPU module.
Offset/gain setting		Corrects errors in digital output values.
Backing up, saving, and restoring offset/gain values		Makes it possible to back up, save, and restore the offset/gain values of the user range setting.
Online module change		Allows module replacement without stopping the system. For the procedure of the online module change, refer to the following.  MELSEC iQ-R Online Module Change Manual

## Availability in each operation mode

The functions that can be used depend on the operation mode of the A/D converter module. The following table lists the availability of each function in each operation mode.

○: Available, ×: Not available

Item		Operation mode				
		Medium speed	Low speed	Simultaneous conversion	Synchronization	
Range switching function		○	○	○	○	
A/D conversion enable/disable setting function		○	○	○	○	
A/D conversion method	Sampling processing	○	○	○	○	
	Averaging processing	Time average	○	○	×	×
		Count average	○	○	×	×
		Moving average	○	○	○	○
	Primary delay filter		○	○	×	×
	Digital filter	Low pass filter	○	○	×	×
		High pass filter	○	○	×	×
Band pass filter		○	○	×	×	
Scaling function		○	○	×	×	
Shift function		○	○	×	×	
Digital clipping function		○	○	×	×	
Difference conversion function		○	○	×	×	
Maximum value/minimum value hold function		○	○	○	○	
Warning output function	Process alarm	○	○	○	○	
	Rate alarm	○	○	×	×	
Input signal error detection function		○	○	○	○	
Logging function	Normal logging function	×	○	×	×	
	Continuous logging function	×	×	○	○	
Inter-module synchronization function		×	×	×	○	
Interrupt function		×	○	○	○	
Error history function		○	○	○	○	
Event history function		○	○	○	○	

Item	Operation mode			
	Medium speed	Low speed	Simultaneous conversion	Synchronization
Offset/gain setting	<input type="radio"/>	<input type="radio"/>	<input checked="" type="radio"/>	<input checked="" type="radio"/>
Backing up, saving, and restoring offset/gain values	<input type="radio"/>	<input type="radio"/>	<input checked="" type="radio"/>	<input checked="" type="radio"/>
Online module change	<input type="radio"/>	<input type="radio"/>	<input type="radio"/>	<input type="radio"/>

# 4 PROCEDURES BEFORE OPERATION

---

This chapter describes the procedures before operation.

## 1. Mounting a module

Mount the A/D converter module in any desired configuration.

## 2. Wiring

Perform wiring of external devices to the A/D converter module.

 Page 26 External Wiring

## 3. Adding a module

Add the A/D converter module to a module configuration by using the engineering tool. For details, refer to the following.

 GX Works3 Operating Manual

## 4. Parameter setting

Set the parameters of the A/D converter module by using the engineering tool. For details, refer to the following.

 MELSEC iQ-R High Speed Analog-Digital Converter Module User's Manual (Application)

## 5. Offset/gain setting

Perform the offset/gain setting to set a user range, if necessary.

 Page 35 OFFSET/GAIN SETTING

## 6. Programming

Create a program. For details, refer to the following.

 Page 28 OPERATION EXAMPLES





# 5 WIRING

This chapter describes the wiring of the A/D converter module.

## 5.1 Terminal Block

### Precautions

Tighten the module fixing screws and others within the specified torque range.

Screw type	Tightening torque range
Module fixing screw (M3) <sup>*1</sup>	0.37 to 0.48N-m
Terminal screw (M3)	0.42 to 0.58N-m
Terminal block mounting screw (M3.5)	0.66 to 0.89N-m

\*1 The hook on the top of the module allows the module to be fixed to a base unit easily. In a place where there is a lot of vibration, however, fixing with module fixing screws is recommended.

The following table lists an applicable solderless terminal to be connected to the terminal block. When wiring, use the applicable wire and tightening torque in the table. Use UL listed solderless terminals and, for processing, use the tools recommended by their manufacturer. Note that a solderless terminal with an insulation sleeve cannot be used.

Solderless terminal		Wire			
Model	Applicable tightening torque	Diameter	Type	Material	Temperature rating
R1.25-3	0.42 to 0.58N-m	0.3 to 0.75mm <sup>2</sup> (22 to 18 AWG)	Stranded wire	Copper	75°C or greater

### Signal names of the terminal block

The following table shows signal names of the terminal block.

Terminal block	Terminal number	Signal name
	1	CH1 V+
	2	CH1 V-/I-
	3	CH1 I+
	4	SLD
	5	CH2 V+
	6	CH2 V-/I-
	7	CH2 I+
	8	SLD
	9	CH3 V+
	10	CH3 V-/I-
	11	CH3 I+
	12	SLD
	13	CH4 V+
	14	CH4 V-/I-
	15	CH4 I+
	16	SLD
	17	AG
	18	FG

**Point** 

---

Terminal blocks that have been used on MELSEC-Q series analog-digital converter modules can be used just the way they are. The terminal layout is the same as the MELSEC-Q series high speed analog-digital converter modules (Q64ADH).

The terminal blocks for MELSEC-L series analog-digital converter modules, however, cannot be used because of the shape difference.

---

# 5.2 External Wiring

## Wiring to the terminal block

The following figures show wiring to the terminal block.

- For the voltage input

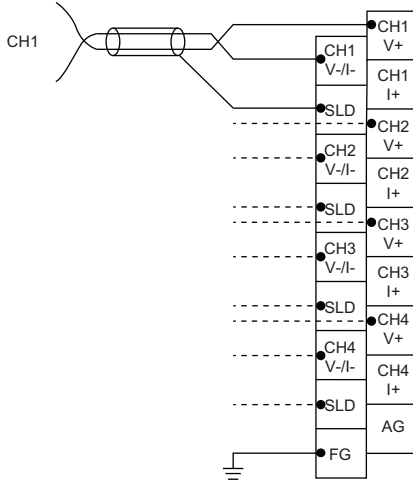

- For the current input

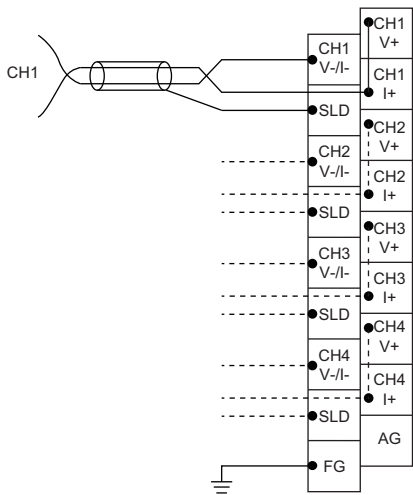

## External wiring examples

The following figures show the examples of external wiring.

For voltage input

Signal source -10 to 10V

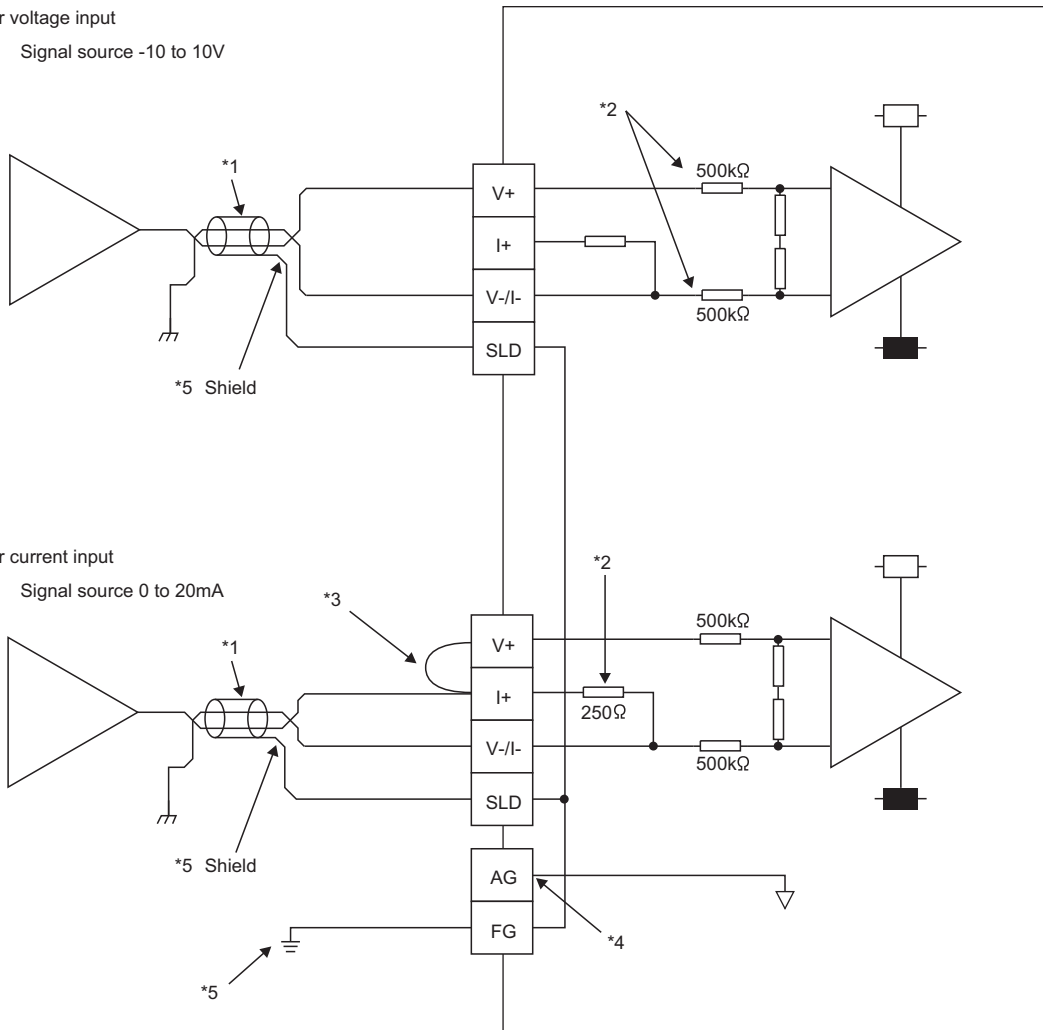

\*1 For the wire, use the 2-core twisted cable.

\*2 This indicates the input resistance of the A/D converter module.

\*3 For the current input, be sure to connect the terminals (V+) and (I+).

\*4 Connect the AG terminal and the GND of the external device if there is a potential difference between them.

\*5 Be sure to connect the shield wire of cables on each channel to the SLD terminal, and ground the FG terminal.

### Point

Ground the FG terminal of the power supply module.

If the circuit is left open between terminals of unused channels, enabling A/D conversion may generate an undefined digital value. To prevent this phenomenon, take any of the following measures:

- Set the A/D conversion enable/disable setting in the unused channels to disable the A/D conversion. Note that in the normal mode, changing the A/D conversion enable/disable setting from A/D conversion enable to A/D conversion disable causes a shorter sampling cycle.
- Short-circuit the input terminals (V+) and (V-) in the unused channels.

# 6 OPERATION EXAMPLES

---

This chapter describes the programming procedure and the basic program of the A/D converter module.

## 6.1 Programming Procedure

---

Take the following steps to create a program for running the A/D converter module:

**1.** Set parameters.

 Page 29 Parameter settings

**2.** Create a program.

 Page 32 Program examples

---

### **Point**

Using function blocks (FBs) reduces load at programming and improves the readability of programs. For details on the function blocks, refer to the following.

 MELSEC iQ-R Analog-Digital Converter Module/Digital-Analog Converter Module Function Block Reference

---

## 6.2 Program Examples

### System configuration

The following figure shows an example of the system configuration.

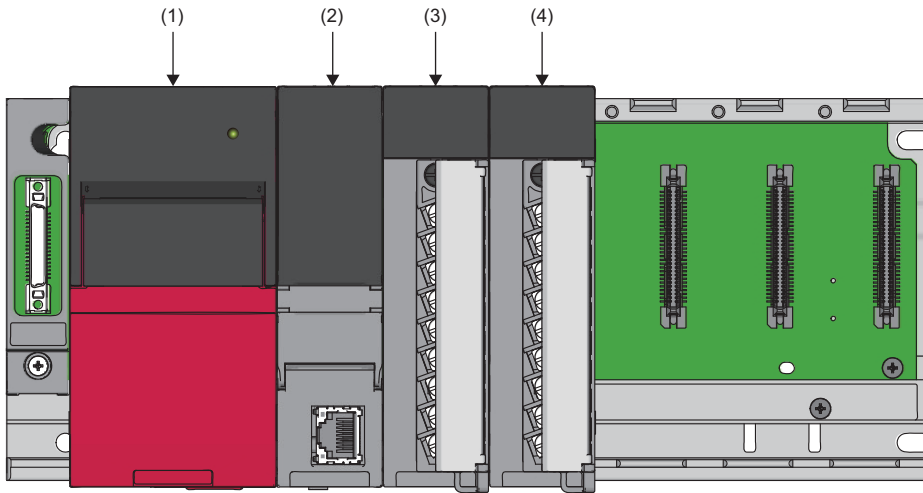

- (1) Power supply module (R61P)
- (2) CPU module (R04CPU)
- (3) A/D converter module (R60ADH4)
- (4) Input module (RX10)

### Conditions in the program

This program reads digital output values from the A/D converter module's CH1 to CH4 where A/D conversion is enabled. The A/D conversion takes place in CH1 and CH4 by means of sampling processing; in CH2 by means of averaging processing for 50 samples; and in CH3 by means of moving average for 10 samples.

### Parameter settings

Perform initial settings in the parameter settings of the engineering tool. The auto refresh setting does not need to be changed here.

For details on the parameter settings, refer to the following.

📖 MELSEC iQ-R High Speed Analog-Digital Converter Module User's Manual (Application)

Function	Setting item	CH1	CH2	CH3	CH4
Range switching function	Input range setting	-10 to 10V	0 to 10V	0 to 20mA	4 to 20mA
Operation mode setting function	Operation mode setting	Normal mode (low speed: 20 $\mu$ s/CH)			
A/D conversion enable/disable setting function	A/D conversion enable/disable setting	A/D conversion enable	A/D conversion enable	A/D conversion enable	A/D conversion enable
A/D conversion method	Averaging process specification	Sampling processing	Count average	Moving average	Sampling processing
	Time average/Count average/Moving average/Primary delay filter constant setting	—	50 times	10 times	—
Scaling function	Scaling enable/disable setting	—	—	Enable	—
	Scaling upper limit value	—	—	16000	—
	Scaling lower limit value	—	—	2000	—
Shift function	Conversion value shift amount	0	0	2000	0

Function	Setting item	CH1	CH2	CH3	CH4
Warning output function (process alarm)	Warning output setting (Process alarm)	Disable	Enable	Disable	Disable
	Process alarm upper upper limit value	—	32000	—	—
	Process alarm upper lower limit value	—	28000	—	—
	Process alarm lower upper limit value	—	4000	—	—
	Process alarm lower lower limit value	—	0	—	—
Warning output function (rate alarm)	Warning output setting (Rate alarm)	Enable	Disable	Disable	Disable
	Rate alarm warning detection cycle setting	5 times	—	—	—
	Rate alarm upper limit value	25.0%	—	—	—
	Rate alarm lower limit value	-5.0%	—	—	—
Input signal error detection function	Input signal error detection setting	Upper and lower limit detection	Disable	Disable	Disable
	Input signal error detection lower limit setting value	5.0%	—	—	—
	Input signal error detection upper limit setting value	10.0%	—	—	—

Set default values for the parameters other than the above.

## Label settings

GX Works3 provides functions that support the creation of a program.

The following table lists the module labels and global labels used for the program examples in this section.

There is no need to change the settings of the module labels. For details on the global labels, refer to the following.

📖 MELSEC iQ-R Programming Manual (Program Design)

Classification	Label name	Description	Device
Module label	R60ADH_1.bModuleREADY	Module READY	X0
	R60ADH_1.bInputSignalErrorDetectionSignal	Input signal error detection signal	X0C
	R60ADH_1.bMaxValueMinValueResetCompletedFlag	Maximum value/minimum value reset completed flag	X0D
	R60ADH_1.bA_D_conversionCompletedFlag	A/D conversion completed flag	X0E
	R60ADH_1.bErrorFlag	Error flag	X0F
	R60ADH_1.bOperatingConditionSettingRequest	Operating condition setting request	Y9
	R60ADH_1.bMaxValueMinValueResetRequest	Maximum value/minimum value reset request	Y0D
	R60ADH_1.uA_D_conversionCompletedFlag.0	CH1 A/D conversion completed flag	U0\G42.0
	R60ADH_1.stnMonitor[0].wDigitalOutputValue	CH1 Digital output value	U0\G400
	R60ADH_1.uA_D_conversionCompletedFlag.1	CH2 A/D conversion completed flag	U0\G42.1
	R60ADH_1.stnMonitor[1].wDigitalOutputValue	CH2 Digital output value	U0\G600
	R60ADH_1.uA_D_conversionCompletedFlag.2	CH3 A/D conversion completed flag	U0\G42.2
	R60ADH_1.stnMonitor[2].wDigitalOperationValue	CH3 Digital operation value	U0\G802
	R60ADH_1.uA_D_conversionCompletedFlag.3	CH4 A/D conversion completed flag	U0\G42.3
	R60ADH_1.stnMonitor[3].wDigitalOutputValue	CH4 Digital output value	U0\G1000
	R60ADH_1.stnMonitor[2].wMaxValue	CH3 Maximum value	U0\G404
	R60ADH_1.stnMonitor[2].wMinValue	CH3 Minimum value	U0\G406
	R60ADH_1.uWarningOutputFlagProcessAlarmUpperLimit.1	CH2 Warning output flag (Process alarm upper limit)	U0\G36.1
	R60ADH_1.uWarningOutputFlagProcessAlarmLowerLimit.1	CH2 Warning output flag (Process alarm lower limit)	U0\G37.1
	R60ADH_1.uWarningOutputFlagRateAlarmUpperLimit.0	CH1 Warning output flag (Rate alarm upper limit)	U0\G38.0
R60ADH_1.uWarningOutputFlagRateAlarmLowerLimit.0	CH1 Warning output flag (Rate alarm lower limit)	U0\G39.0	
R60ADH_1.uInputSignalErrorDetectionFlag.0	CH1 Input signal error detection flag	U0\G40.0	



Classification	Label name	Description	Device
Labels to be defined	Define global labels as shown below:		
	Label Name	Data Type	Class Assign (Device/Label)
	DigitOutValSig	Bit	... VAR_GLOBAL X1 0
	CH1_DieOutVal	Word [Unsigned]/Bit String [1 6-bit]	... VAR_GLOBAL D1 1
	CH2_DieOutVal	Word [Unsigned]/Bit String [1 6-bit]	... VAR_GLOBAL D1 2
	CH3_DieOutVal	Word [Unsigned]/Bit String [1 6-bit]	... VAR_GLOBAL D1 3
	CH4_DieOutVal	Word [Unsigned]/Bit String [1 6-bit]	... VAR_GLOBAL D1 4
	MaxMinReadSig	Bit	... VAR_GLOBAL X1 1
	MaxMinResetSig	Bit	... VAR_GLOBAL X1 2
	CH3_DieMaxVal	Word [Unsigned]/Bit String [1 6-bit]	... VAR_GLOBAL D1 5
	CH3_DieMinVal	Word [Unsigned]/Bit String [1 6-bit]	... VAR_GLOBAL D1 6
	CH2_ProcAimUpLimit	Bit	... VAR_GLOBAL F0
	CH2_ProcAimLowLimit	Bit	... VAR_GLOBAL F1
	CH1_RateAimUpLimit	Bit	... VAR_GLOBAL F2
	CH1_RateAimLowLimit	Bit	... VAR_GLOBAL F3
	CH1_InputsSigErr	Bit	... VAR_GLOBAL F4
	ErrOperationEN	Bit	... VAR_GLOBAL
	ErrResetSig	Bit	... VAR_GLOBAL X1 3
	ErrOperationEND	Bit	... VAR_GLOBAL
	ErrOperationOK	Bit	... VAR_GLOBAL
	UnitErrFlg	Bit	... VAR_GLOBAL
	UnitErrCode	Word [Unsigned]/Bit String [1 6-bit]	... VAR_GLOBAL
	UnitAlarmCode	Word [Unsigned]/Bit String [1 6-bit]	... VAR_GLOBAL

## Program examples

### Program example 1

This program is an example to read and save the digital output values of CH1, CH2, and CH4, and the digital operation value of CH3.

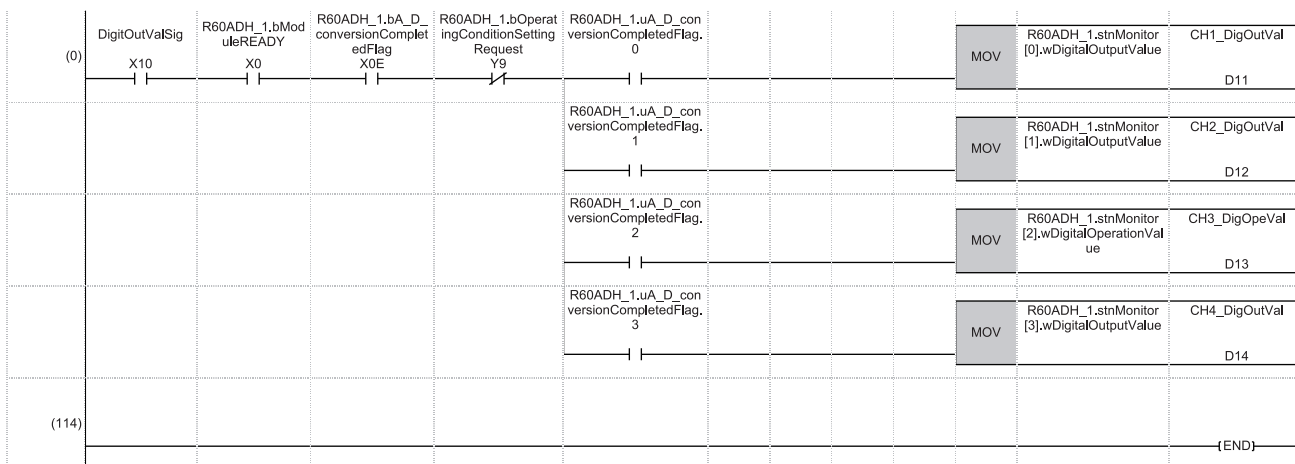

(0) CH1 Digital output value, CH2 Digital output value, CH3 Digital operation value, and CH4 Digital output value are to be read.

### Program example 2

This program is an example to read the maximum and minimum values of CH3, which in turn are cleared.

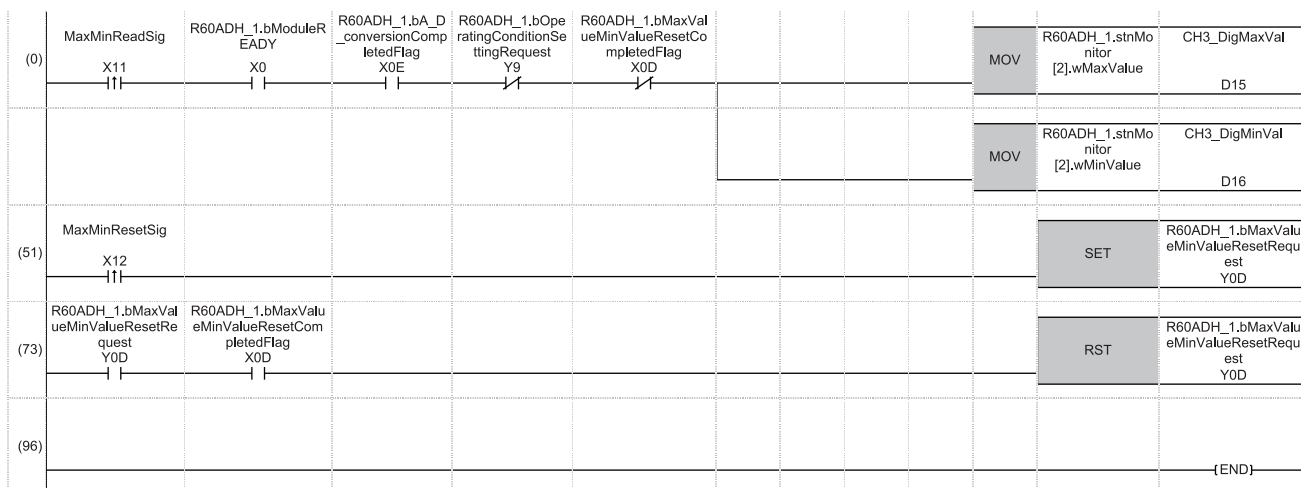

(0) CH3 Maximum value and CH3 Minimum value are to be read.

(51)'Maximum value/minimum value reset request' (YD) is to be turned on.

(73)'Maximum value/minimum value reset request' (YD) is to be turned off.

### Program example 3

This program is an example to perform the processing at the time when a process alarm upper/lower limit warning is issued in CH2.

(0)	R60ADH_1.uWarning OutputFlagProcessAlarmUpperLimit.1																					SET	CH2_ProcAlmUpLimit		
																								F0	
(43)	R60ADH_1.uWarning OutputFlagProcessAlarmLowerLimit.1																						SET	CH2_ProcAlmLowLimit	
																									F1
(72)																									{END}

- (0) The processing at the time when a process alarm upper limit warning is issued in CH2 is to be performed.
- (43)The processing at the time when a process alarm lower limit warning is issued in CH2 is to be performed.

### Program example 4

This program is an example to perform the processing at the time when a rate alarm upper/lower limit warning is issued in CH1.

(0)	R60ADH_1.uWarning OutputFlagRateAlarm UpperLimit.0	SET	CH1_RateAlmUpLimit
	↑		F2
(41)	R60ADH_1.uWarning OutputFlagRateAlarm LowerLimit.0	SET	CH1_RateAlmLowLimit
	↑		F3
(69)			{END}

(0) The processing at the time when a rate alarm upper limit warning is issued in CH1 is to be performed.

(41) The processing at the time when a rate alarm lower limit warning is issued in CH1 is to be performed.

### Program example 5

This program is an example where after the processing of an input signal error of CH1, Input signal error detection flag and the stored error code are cleared.

(0)	R60ADH_1.uInput SignalErrorDetect ionFlag.0	SET	CH1_InputSigErr
	↑		F4
(33)	R60ADH_1.bInput SignalErrorDetect ionSignal X0C	SET	ErrOperationEN
	↑		
	R60ADH_1.bError Flag X0F		
	↑		
(62)	M_R60ADH_OperateError_00A_1 ( M+R60ADH_OperateError_00A ) Monitor error and reset FB		
	ErrOperationEN	Bi_bEN	o_bENO.B
	↑		○
		R60ADH_1 [ ] DUTi_stModule	o_bOK.B
			○
	ErrResetSig X13	Bi_bErrReset	o_bUnitErr.B
	↑		○
			UnitErrCode.UW
			[ ]
			UnitAlarmCode.UW
			[ ]
			o_bErr.B
			o_uErrId.UW
(123)			{END}

(0) The processing at the time when an input signal error is detected in CH1 is to be performed.

(33) Error manipulation start flag is to be turned on.

# 7 OFFSET/GAIN SETTING

Using the user range setting requires setting the offset and gain values.

Access the offset/gain setting window in the engineering tool to set the offset and gain values.

## Restriction

The offset/gain setting is disabled in the simultaneous conversion mode and the inter-module synchronization mode. Change the mode to the normal mode or the offset/gain setting mode and set the offset and gain values.

## 7.1 Setting Procedure

The procedure for the offset/gain setting of the A/D converter module is as follows:

[Tool] ⇒ [Module Tool List]

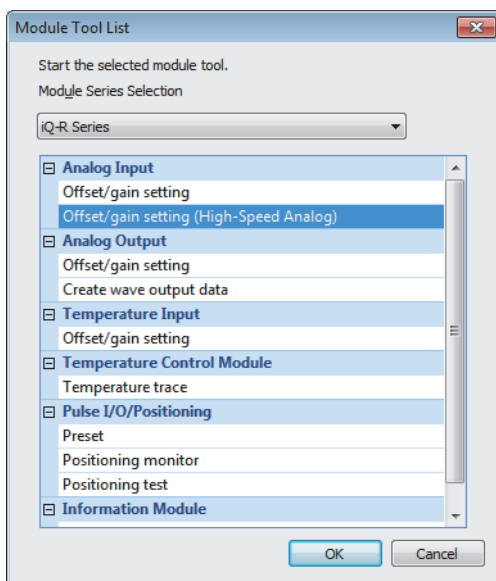

1. In "Analog Input", select "Offset/gain setting (High-Speed Analog)" and click the [OK] button.

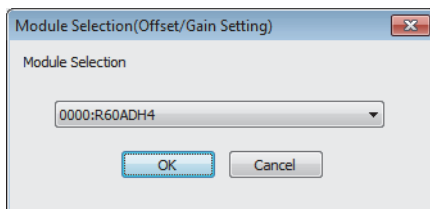

2. Select the target module for the offset/gain setting, and click the [OK] button.

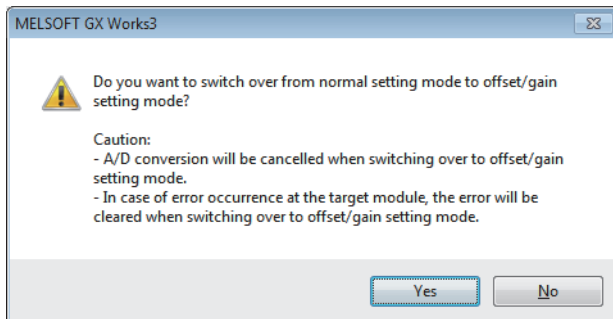

3. Click the [Yes] button.

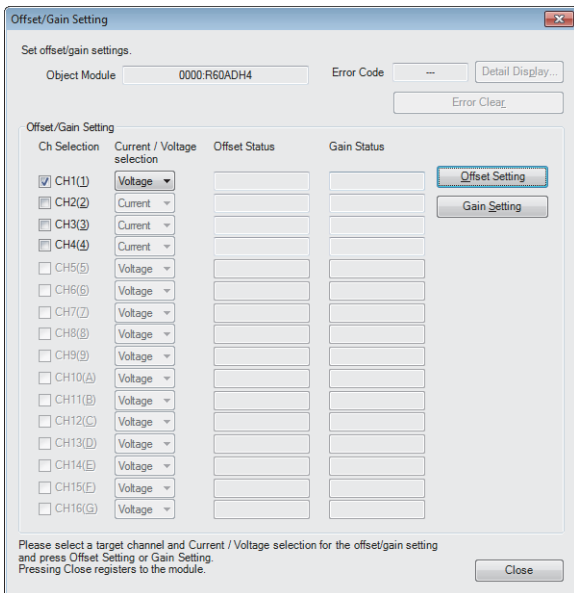

4. Mark the checkbox of the channel where offset and gain values are to be set.
5. Select the voltage or current and click the [Offset Setting] button.

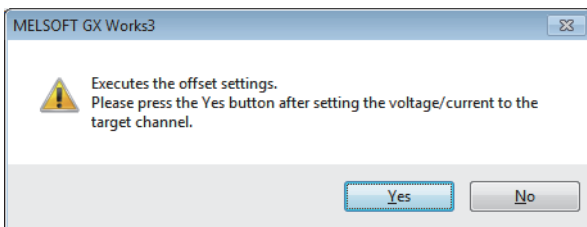

6. Apply the offset voltage or current to the terminal of the corresponding channel, and click the [Yes] button.

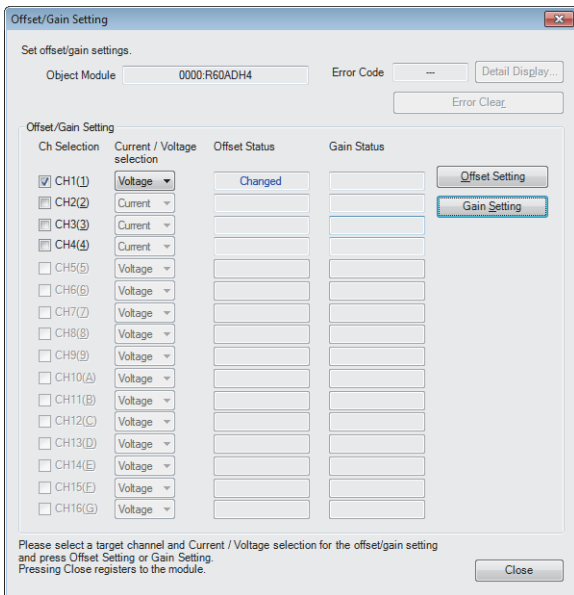

7. Check that "Offset Status" has changed to "Changed", and click the [Gain Setting] button.

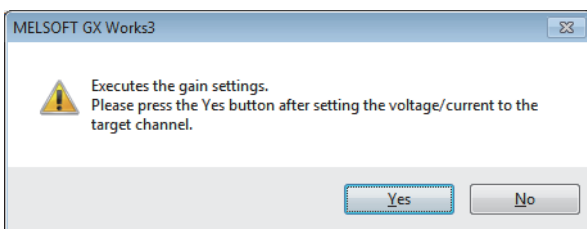

8. Apply the gain voltage or current to the terminal of the corresponding channel, and click the [Yes] button.

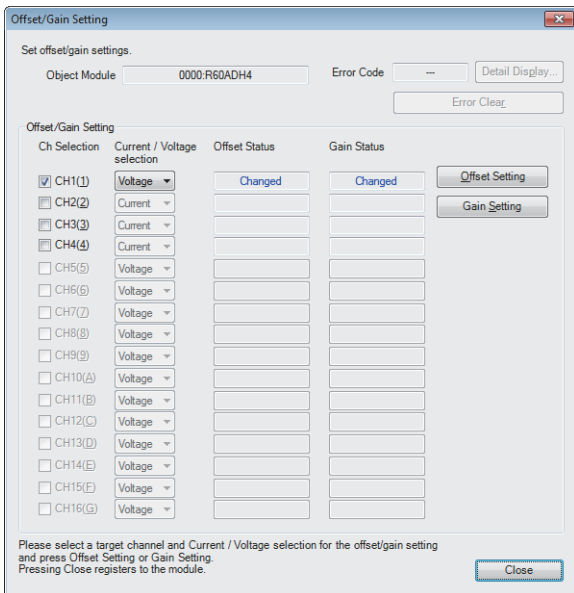

9. Check that "Gain Status" has changed to "Changed", and click the [Close] button.

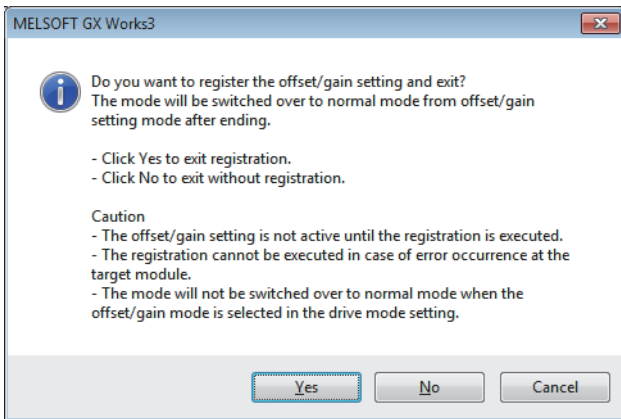

10. Click the [Yes] button.

# APPENDICES

---

## Appendix 1 I/O Conversion Characteristics

---

An I/O conversion characteristic of A/D conversion is expressed by the slope of the straight line connecting the offset value and the gain value at the time when an analog signal (voltage or current) from outside the programmable controller is converted to a digital output value.

### Offset value

---

This value is the analog input value (voltage or current) where the corresponding digital output value is 0.

### Gain value

---

This value is the analog input value (voltage or current) where the corresponding digital output value is 32000.



## Voltage input characteristics

The following shows the lists of the analog input ranges and the graphs of each voltage input characteristic, at the voltage input.

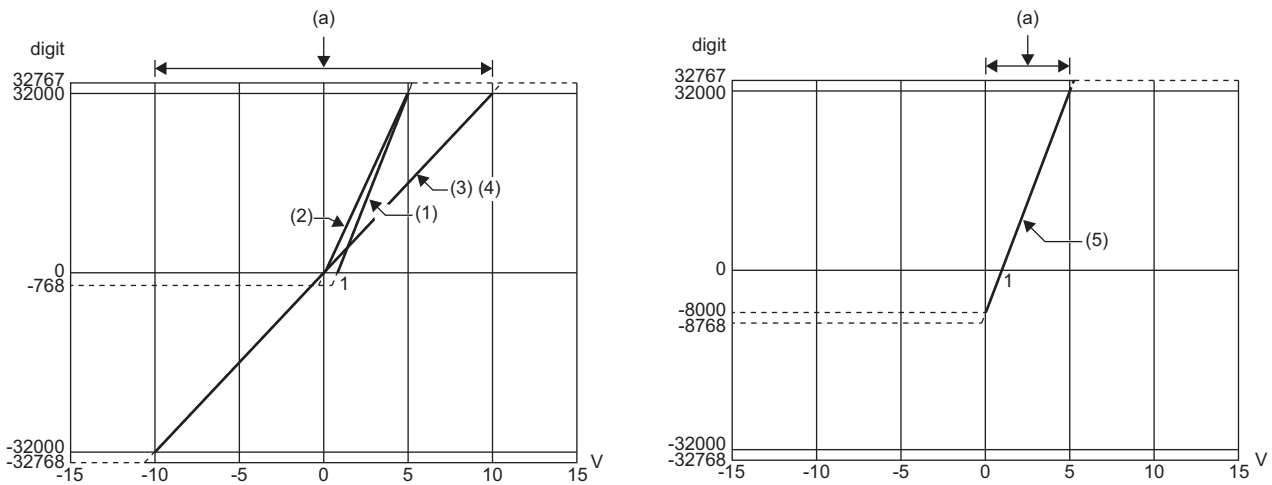

digit: Digital output value

V: Analog input voltage (V)

(a): Practical analog input range

No.	Input range setting	Offset value	Gain value	Digital output value <sup>*3</sup>	Resolution
(1)	1 to 5V	1V	5V	0 to 32000	125.0 $\mu$ V
(2)	0 to 5V	0V	5V		156.3 $\mu$ V
(3)	-10 to 10V	-10V	10V	-32000 to 32000	312.5 $\mu$ V
(4)	0 to 10V	0	10V	0 to 32000	
(5)	1 to 5V (extended mode)	1V	5V	-8000 to 32000	125.0 $\mu$ V
—	User range setting	*1	*1	-32000 to 32000	125.0 $\mu$ V <sup>*2</sup>

\*1 Set the offset value and gain value in the user range setting within a range that satisfies the following conditions. If the following conditions are not satisfied, A/D conversion may not be performed properly.

Setting range of the offset value and gain value: -10 to 10V

$((\text{gain value}) - (\text{offset value})) \geq 4.0\text{V}$

\*2 Maximum resolution in the user range setting.

\*3 When analog input exceeds the range of the digital output value, the digital output value is fixed to the maximum or minimum.

Input range setting	Digital output value	
	Minimum	Maximum
1 to 5V	-768	32767
0 to 5V		
-10 to 10V	-32768	
0 to 10V	-768	
1 to 5V (extended mode)	-8768	
User range setting	-32768	

### Point

- Set values within the practical range of the analog input and digital output at each input range. If the values are out of the range, the resolution and accuracy may not fall within the range of the performance specifications. (Do not use values in the dotted line regions in the graphs of voltage input characteristics.)
- The range of 1 to 5V (extended mode) allows extending the lower limit value of analog input. The upper limit value of analog input cannot be extended.
- Do not set the voltage over  $\pm 15\text{V}$ . Doing so can cause breakdown of the elements.

## Current input characteristics

The following shows the lists of the analog input ranges and the graphs of each current input characteristic, at the current input.

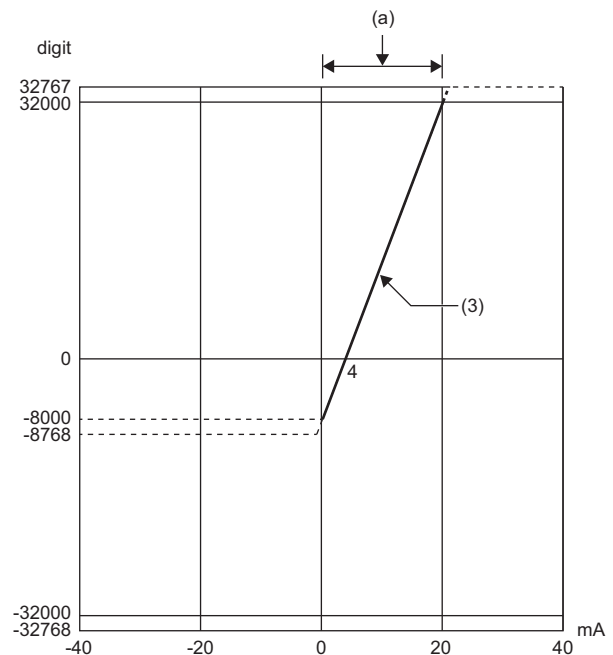
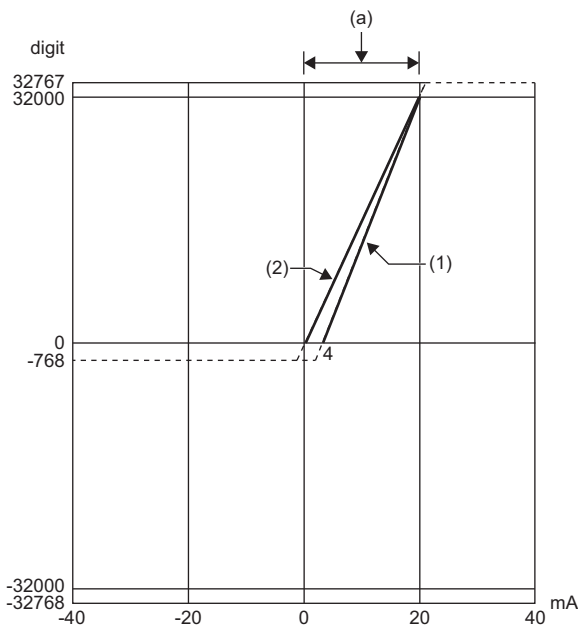

digit: Digital output value  
 mA: Analog input current (mA)  
 (a): Practical analog input range

No.	Input range setting	Offset value	Gain value	Digital output value <sup>*3</sup>	Resolution
(1)	4 to 20mA	4mA	20mA	0 to 32000	500.0nA
(2)	0 to 20mA	0mA	20mA		625.0nA
(3)	4 to 20mA (extended mode)	4mA	20mA	-8000 to 32000	500.0nA
—	User range setting	*1	*1	-32000 to 32000	500.0nA <sup>*2</sup>

\*1 Set the offset value and gain value in the user range setting within a range that satisfies the following conditions. If the following conditions are not satisfied, A/D conversion may not be performed properly.

Gain value  $\leq$  20mA, offset value  $\geq$  0mA  
 ((gain value) - (offset value))  $\geq$  16.0mA

\*2 Maximum resolution in the user range setting.

\*3 When analog input exceeds the range of the digital output value, the digital output value is fixed to the maximum or minimum.

Input range setting	Digital output value	
	Minimum	Maximum
4 to 20mA	-768	32767
0 to 20mA		
4 to 20mA (extended mode)	-8768	
User range setting	-32768	

### Point

- Set values within the practical range of the analog input and digital output at each input range. If the values are out of the range, the resolution and accuracy may not fall within the range of the performance specifications. (Do not use values in the dotted line regions in the graphs of current input characteristics.)
- The range of 4 to 20mA (extended mode) allows extending the lower limit value of analog input. The upper limit value of analog input cannot be extended.
- Do not set the current over  $\pm 30$ mA. Doing so can cause breakdown of the elements.

# Appendix 2 Accuracy

Accuracy of A/D conversion is determined by the accuracy of the maximum value of digital output value.

An input characteristic change through changes of the offset/gain setting or the input range does not sacrifice the accuracy, which is maintained within the described range of the performance specifications.

The following graph shows the fluctuation range of accuracy when the range of -10 to 10V is selected.

The accuracy is  $\pm 0.1\%$  ( $\pm 32$  digit) at ambient temperature of  $25 \pm 5^\circ\text{C}$ ; the accuracy is  $\pm 0.2\%$  ( $\pm 64$  digit) at ambient temperature of 0 to  $55^\circ\text{C}$  (except for the conditions under noise influence).

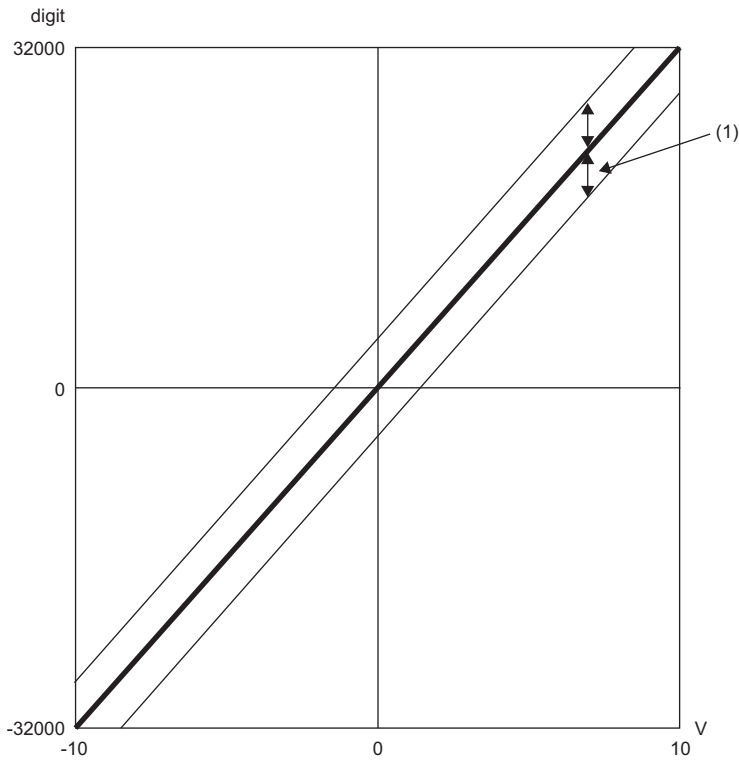

digit: Digital output value  
V: Analog input value (V)  
(1) Fluctuation range



# Appendix 3 Input Response Time

The input response time is the time taken for an analog input signal to reach the internal A/D converter. The time is extended or reduced depending on the variation of analog input. Note that the input response time becomes longer (20µs at a maximum) in the system with sudden input changes.

The following figure shows the input response time of when the analog input is changed from the lower limit value (-10V) to the upper limit value (10V) of the input range.

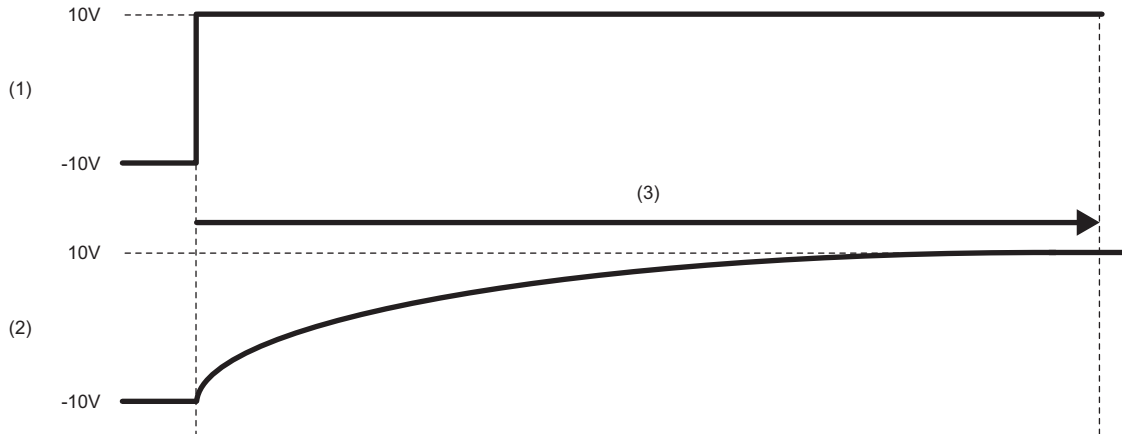

- (1) External input signal
- (2) Input signal to the A/D converter
- (3) Input response time

# Appendix 4 External Dimensions

The following figure shows the external dimensions of the A/D converter module.

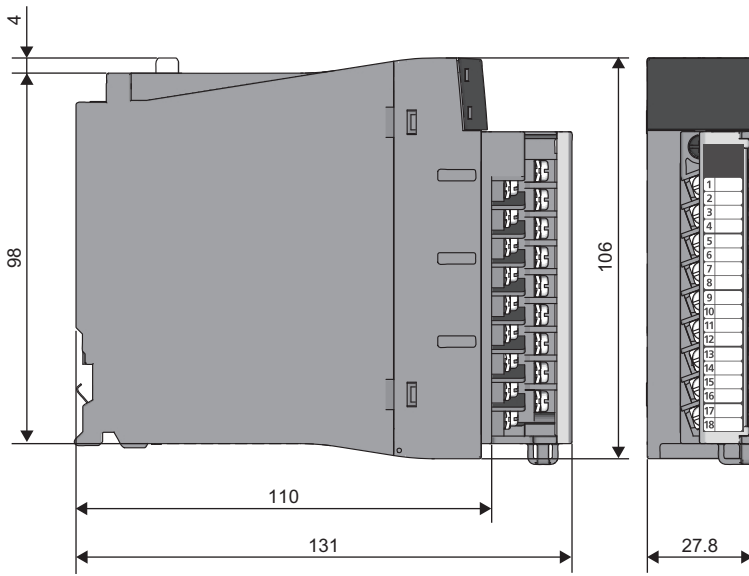

(unit: mm)

# INDEX

---

## A

---

Accuracy of A/D conversion . . . . .	41
ALM LED . . . . .	15

## C

---

Current input characteristics. . . . .	40
--	----

## E

---

ERR LED . . . . .	15
External dimensions . . . . .	43
External wiring . . . . .	26
External wiring examples . . . . .	27

## F

---

Function block (FB). . . . .	28
------------------------------	----

## G

---

Gain value . . . . .	38
----------------------	----

## I

---

Input response time. . . . .	42
------------------------------	----

## O

---

Offset value . . . . .	38
Offset/gain setting . . . . .	35

## P

---

Performance specifications . . . . .	17
Production information marking . . . . .	15
Program examples . . . . .	29

## R

---

RUN LED. . . . .	15
------------------	----

## S

---

Signal names of the terminal block . . . . .	24
--	----

## T

---

Terminal block . . . . .	15,24
--------------------------	-------

## V

---

Voltage input characteristics. . . . .	39
--	----

# MEMO

---

# REVISIONS

---

\*The manual number is given on the bottom left of the back cover.

Revision date	*Manual number	Description
January 2016	SH(NA)-081580ENG-A	First edition

Japanese manual number: SH-081578-A

---

This manual confers no industrial property rights of any other kind, nor does it confer any patent licenses. Mitsubishi Electric Corporation cannot be held responsible for any problems involving industrial property rights which may occur as a result of using the contents noted in this manual.

---

© 2016 MITSUBISHI ELECTRIC CORPORATION



# WARRANTY

---

Please confirm the following product warranty details before using this product.

## **1. Gratis Warranty Term and Gratis Warranty Range**

If any faults or defects (hereinafter "Failure") found to be the responsibility of Mitsubishi occurs during use of the product within the gratis warranty term, the product shall be repaired at no cost via the sales representative or Mitsubishi Service Company.

However, if repairs are required onsite at domestic or overseas location, expenses to send an engineer will be solely at the customer's discretion. Mitsubishi shall not be held responsible for any re-commissioning, maintenance, or testing on-site that involves replacement of the failed module.

[Gratis Warranty Term]

The gratis warranty term of the product shall be for one year after the date of purchase or delivery to a designated place. Note that after manufacture and shipment from Mitsubishi, the maximum distribution period shall be six (6) months, and the longest gratis warranty term after manufacturing shall be eighteen (18) months. The gratis warranty term of repair parts shall not exceed the gratis warranty term before repairs.

[Gratis Warranty Range]

- (1) The range shall be limited to normal use within the usage state, usage methods and usage environment, etc., which follow the conditions and precautions, etc., given in the instruction manual, user's manual and caution labels on the product.
- (2) Even within the gratis warranty term, repairs shall be charged for in the following cases.
  1. Failure occurring from inappropriate storage or handling, carelessness or negligence by the user. Failure caused by the user's hardware or software design.
  2. Failure caused by unapproved modifications, etc., to the product by the user.
  3. When the Mitsubishi product is assembled into a user's device, Failure that could have been avoided if functions or structures, judged as necessary in the legal safety measures the user's device is subject to or as necessary by industry standards, had been provided.
  4. Failure that could have been avoided if consumable parts (battery, backlight, fuse, etc.) designated in the instruction manual had been correctly serviced or replaced.
  5. Failure caused by external irresistible forces such as fires or abnormal voltages, and Failure caused by force majeure such as earthquakes, lightning, wind and water damage.
  6. Failure caused by reasons unpredictable by scientific technology standards at time of shipment from Mitsubishi.
  7. Any other failure found not to be the responsibility of Mitsubishi or that admitted not to be so by the user.

## **2. Onerous repair term after discontinuation of production**

- (1) Mitsubishi shall accept onerous product repairs for seven (7) years after production of the product is discontinued. Discontinuation of production shall be notified with Mitsubishi Technical Bulletins, etc.
- (2) Product supply (including repair parts) is not available after production is discontinued.

## **3. Overseas service**

Overseas, repairs shall be accepted by Mitsubishi's local overseas FA Center. Note that the repair conditions at each FA Center may differ.

## **4. Exclusion of loss in opportunity and secondary loss from warranty liability**

Regardless of the gratis warranty term, Mitsubishi shall not be liable for compensation to:

- (1) Damages caused by any cause found not to be the responsibility of Mitsubishi.
- (2) Loss in opportunity, lost profits incurred to the user by Failures of Mitsubishi products.
- (3) Special damages and secondary damages whether foreseeable or not, compensation for accidents, and compensation for damages to products other than Mitsubishi products.
- (4) Replacement by the user, maintenance of on-site equipment, start-up test run and other tasks.

## **5. Changes in product specifications**

The specifications given in the catalogs, manuals or technical documents are subject to change without prior notice.

# TRADEMARKS

---

The company names, system names and product names mentioned in this manual are either registered trademarks or trademarks of their respective companies.

In some cases, trademark symbols such as <sup>™</sup> or <sup>®</sup> are not specified in this manual.



SH(NA)-081580ENG-A(1601)MEE

MODEL: R60ADH4-U-IN-E

MODEL CODE: 13JX45

## **mitsubishi electric corporation**

HEAD OFFICE : TOKYO BUILDING, 2-7-3 MARUNOUCHI, CHIYODA-KU, TOKYO 100-8310, JAPAN  
NAGOYA WORKS : 1-14, YADA-MINAMI 5-CHOME, HIGASHI-KU, NAGOYA, JAPAN

When exported from Japan, this manual does not require application to the  
Ministry of Economy, Trade and Industry for service transaction permission.

Specifications subject to change without notice.