

# Indicators M22N

## 22-mm Indicators

### Easy to Use

- Screw terminal structure is compatible with round crimp terminals.

### Product Lineup

- Meets global safety standards.
- Many color variations.
- Standard-feature degree of protection: IP66, NEMA 4X, and NEMA 13.



 Refer to *Safety Precautions for All Pushbutton Switches/Indicators* and *Safety Precautions* on page 8.

## Indicator Unit Colors

	Red	Green	Yellow	White	Blue	Orange	White
When not lit							
When lit							

\* The colors when the Switches are lit are for transparent white Indicator Units (code: TW) and yellow LED Lamps (code: Y).

# M22N

## List of Models

Appearance	Model
Plastic flat 	<b>M22N-BN</b>
Plastic projected 	<b>M22N-BP</b>
Plastic semi-spherical 	<b>M22N-BG</b>
Plastic flat etched 	<b>M22N-BC</b>

## Model Number Structure

**Model Number Legend** -- Shipped as a set that includes the Indicator Unit, LED Lamp, and Socket Unit.  
For information on combinations, refer to *Ordering Information* on page 4.

### Model Numbers for Sets

M 2 2 N - <sup>(1)</sup>BN - <sup>(2)</sup>TR <sup>(3)</sup>A - <sup>(4)</sup>R <sup>(5)</sup>A

**(1) Indicator Unit Shape (2) Indicator Color and (4) LED Lamp Color (3) Degree of Protection (5) LED Lamp Voltage**

Code	Shape
BN	Plastic flat
BP	Plastic projected
BG	Plastic semi-spherical
BC	Plastic flat etched

Code (2)	Code (4)	Indicator color	LED Lamp color
TR	R	Red	Red
TG	G	Green	Green
TY	Y	Yellow	Yellow
TW	W	White	White
TA	A	Blue	Blue
TO	O	Orange	Orange
TW	Y	White*	Yellow

Code	Protection
A	IP66, NEMA 4X, NEMA13

Code	LED Lamp voltage
A	6 VAC/DC
B	12 VAC/DC
C	24 VAC/DC
D	100/110/120 VAC
E	200/220/230/240 VAC

\* The color is opaque white when the Indicator is lit.





■ Specifications: Refer to page 5 and refer to the A22NN/A22NL.    ■ Precautions for correct use: Refer to the A22NN/A22NL.  
 ■ Dimensions: Refer to page 7.    ■ Accessories and tools: Refer to the A22NN/A22NL.

# M22N

## Ordering Information

**Model Numbers for Sets** - - - Shipped as a set that includes the Indicator Unit, LED Lamp, and Socket Unit.

### Indicators

Appearance	Operating voltage	Model	(2)(2) Indicator color	(4) LED lamp color
Plastic flat 	6 VAC/DC	M22N-BN-(2)(2)A-(4)A	TR: Transparent red TG: Transparent green TY: Transparent yellow TW: Transparent white TA: Transparent blue TO: Transparent orange	R: Red G: Green Y: Yellow W: White A: Blue O: Orange
	12 VAC/DC	M22N-BN-(2)(2)A-(4)B		
	24 VAC/DC	M22N-BN-(2)(2)A-(4)C		
	100, 110, or 120 VAC	M22N-BN-(2)(2)A-(4)D		
	200, 220, 230, or 240 VAC	M22N-BN-(2)(2)A-(4)E		
Plastic projected 	6 VAC/DC	M22N-BP-(2)(2)A-(4)A		
	12 VAC/DC	M22N-BP-(2)(2)A-(4)B		
	24 VAC/DC	M22N-BP-(2)(2)A-(4)C		
	100, 110, or 120 VAC	M22N-BP-(2)(2)A-(4)D		
	200, 220, 230, or 240 VAC	M22N-BP-(2)(2)A-(4)E		
Plastic semi-spherical 	6 VAC/DC	M22N-BG-(2)(2)A-(4)A		
	12 VAC/DC	M22N-BG-(2)(2)A-(4)B		
	24 VAC/DC	M22N-BG-(2)(2)A-(4)C		
	100, 110, or 120 VAC	M22N-BG-(2)(2)A-(4)D		
	200, 220, 230, or 240 VAC	M22N-BG-(2)(2)A-(4)E		
Plastic flat etched 	6 VAC/DC	M22N-BC-(2)(2)A-(4)A		
	12 VAC/DC	M22N-BC-(2)(2)A-(4)B		
	24 VAC/DC	M22N-BC-(2)(2)A-(4)C		
	100, 110, or 120 VAC	M22N-BC-(2)(2)A-(4)D		
	200, 220, 230, or 240 VAC	M22N-BC-(2)(2)A-(4)E		

**Note:** Normally, the Indicator Unit and LED Lamp with the same color are combined.  
 However, opaque white is available by combining a white Indicator Unit and yellow LED. M22N-B□-TWA-Y□

■ Specifications: Refer to page 5 and refer to the A22NN/A22NL. ■ Dimensions: Refer to page 7.  
 ■ Accessories and tools: Refer to the A22NN/A22NL.

## Ratings and Specifications

### Certified Standard Ratings

#### UL508 (File No.E76675), CSA C22.2 No.14

12 mA 6 VAC/DC  
 12 mA 12 VAC/DC  
 12 mA 24 VAC/DC  
 12 mA 100-120 VAC  
 12 mA 200-240 VAC

#### TÜV (EN60947-5-1)

80 mA 6 VAC/DC  
 40 mA 12 VAC/DC  
 20 mA 24 VAC/DC  
 10 mA 100-120 VAC  
 5 mA 200-240 VAC

#### CCC (GB14048.5)

6, 12, 24 VAC/DC  
 100-120, 200-240 VAC

## Ratings

### LED Lamps

Rated voltage	Operating voltage	Current
6 VAC/DC	6 VAC/DC $\pm$ 10%	Approx. 11 mA (red, orange, yellow, or blue)
		Approx. 5 mA (white or green)
12 VAC/DC	12 VAC/DC $\pm$ 10%	Approx. 12 mA (red, orange, yellow, or blue)
		Approx. 5 mA (white or green)
24 VAC/DC	24 VAC/DC $\pm$ 10%	Approx. 12 mA (red, orange, yellow, or blue)
		Approx. 5 mA (white or green)
100 VAC	100 VAC $\pm$ 10%	Approx. 2 mA
110 VAC	110 VAC $\pm$ 10%	
120 VAC	100-130 VAC	
200 VAC	200 VAC $\pm$ 10%	
220 VAC	220 VAC $\pm$ 10%	Approx. 2 mA
230 VAC	230 VAC $\pm$ 10%	
240 VAC	220-250 VAC	

# M22N

## Specifications

### Characteristics

Item		Type	Indicator
Allowable operating frequency	Mechanical	---	
	Electrical	---	
Insulation resistance			100 M $\Omega$ min. (at 500 VDC)
Contact resistance			---
Dielectric strength	Between terminals of same polarity		2,500 VAC at 50/60 Hz for 1 min
	Between each terminal and ground		2,500 VAC at 50/60 Hz for 1 min
Vibration resistance	Malfunction		10 to 55 Hz, 1.5-mm double amplitude
Shock resistance	Malfunction		1,000 m/s <sup>2</sup> max.
Durability	Mechanical	---	
	Electrical	---	
Ambient operating temperature <sup>*1</sup>			-25 to 55°C
Ambient operating humidity			35% to 85% RH
Ambient storage temperature <sup>*1</sup>			-40 to 80°C
Degree of protection <sup>*2</sup>			IP66, NEMA 4X, NEMA13
Electric shock protection class			Class II
PTI (tracking characteristic)			175
Degree of contamination (application environment)			3 (IEC 60947-5-1)
Weight			Approx. 30 g

\*1. With no icing or condensation.

\*2. Degree of protection from the front of the panel.

# Dimensions

(Unit: mm)

## Indicators

### Plastic Flat Indicators M22N-BN

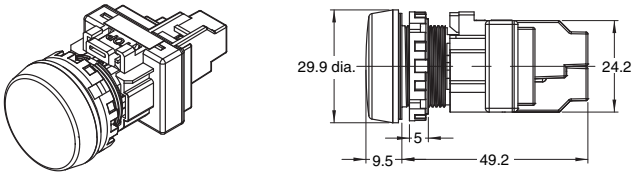

### Plastic Semi-spherical Indicators M22N-BG

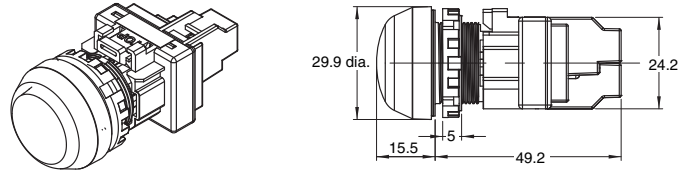

### Plastic Projected Indicators M22N-BP

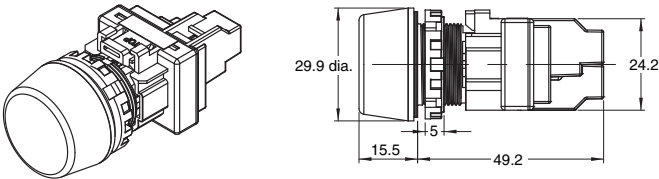

### Plastic Flat Etched Indicators M22N-BC

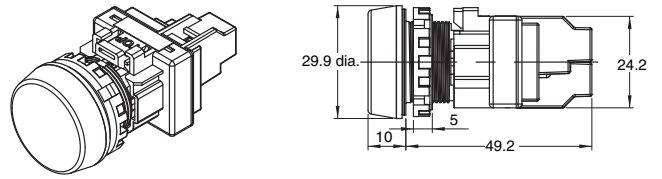

## Safety Precautions

Refer to *Safety Precautions for all Pushbutton Switches/Indicators* for common precautions.

### Precautions for Correct Use

#### Application

##### Mounting to the Panel

- Panel hole dimensions are given below.
- The recommended panel thickness is 0.8 to 6 mm.
- If outer surface treatment such as coating is performed for the panel, the panel dimensions after outer surface treatment must meet the specified panel dimensions.

##### Panel Hole Dimensions for 22.3 Diameter

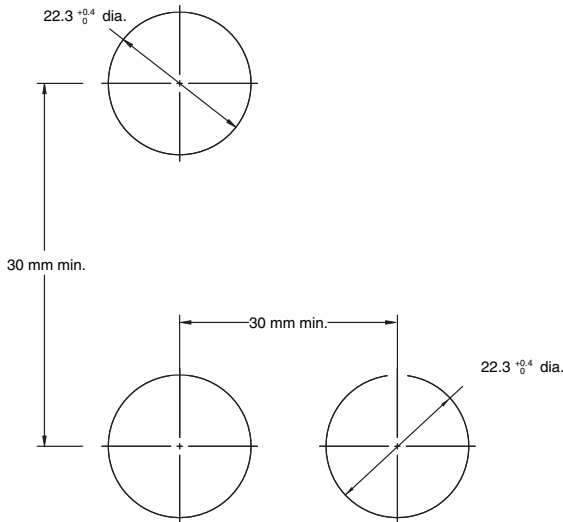

##### Panel Hole Dimensions for 25.5 Diameter

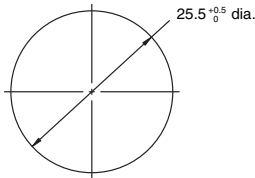

##### Mounting the Indicator Unit

- Panel Hole of 22.3-mm Diameter  
Insert the Indicator Unit from the front of the panel, insert the Lock Ring and Mounting Nut from the back of the panel, and tighten the Mounting Nut. Before tightening, check that the rubber washer is present between the Indicator Unit and the panel.

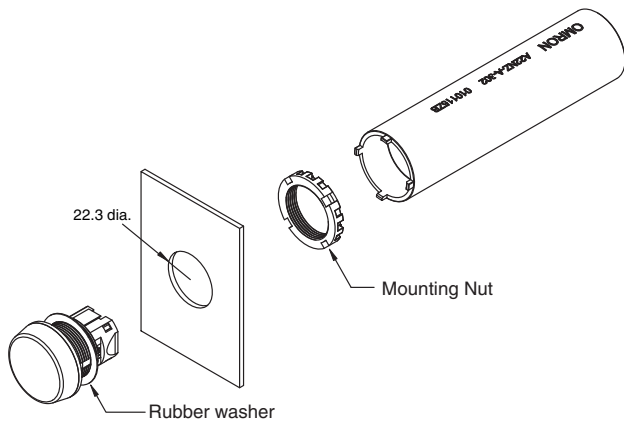

- Panel Hole of 25.5-mm Diameter  
Tighten the Mounting Nut while confirming that the projecting part (see following figure) on the Mounting Nut is aligned with mounting hole.

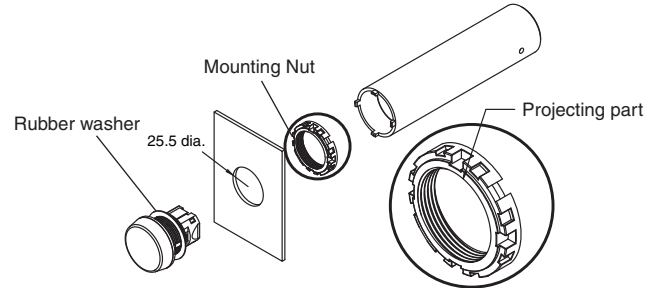

##### Attaching the Switch Unit to the Indicator Unit

- Align the "TOP" marks on the Indicator Unit and Switch Unit and insert the Indicator Unit into the Switch Unit. Insert it all the way until it clicks into place.

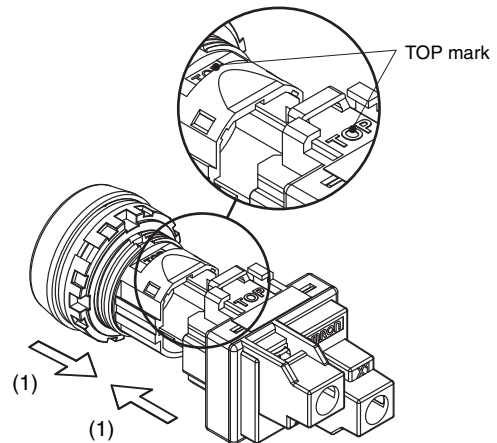

##### Removing the Switch Unit

- Insert a screwdriver into the tab on the Switch Unit. Move the screwdriver in direction (2) to remove the Switch Unit.

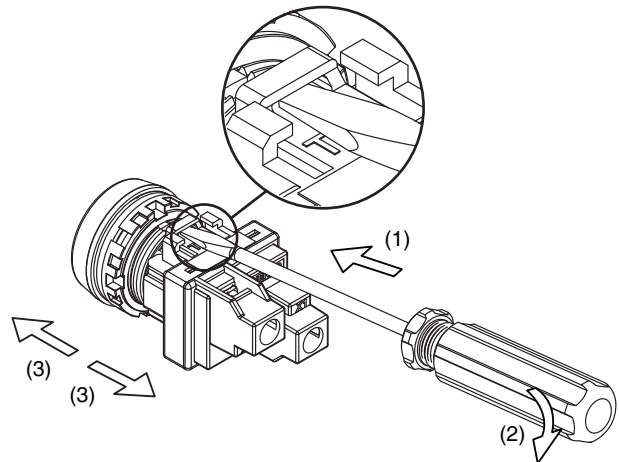



**Engraving**

- Engrave legends on the Legend Plates.  
Do so with the straight part of the Legend Plate positioned on the right and left.
- The characters must be engraved no deeper than 0.5 mm. Use an alcohol-based paint, such as a melamine, phthalic acid, or acrylic resin based paint.



**Attaching Character Films**

- To attach a character film, remove the Button and attach the film, aligning it with the straight portions of the Legend Plate.

**Flat Etched Indicator Units**

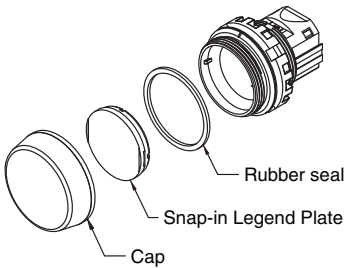

**Flat Indicator Units**

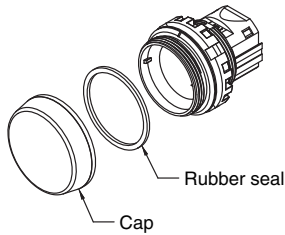

**Semi-spherical Indicator Units**

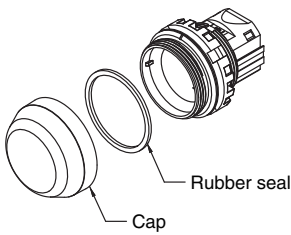

**Projected Indicator Units**

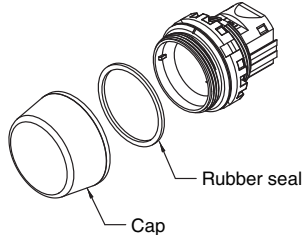

- Prepare films with the following dimensions.

<p><b>Legend Plate dimensions</b></p>	<p>21 dia. 1</p>
<p><b>Film dimensions</b></p>	<p>22.7<sup>0</sup><sub>-0.2</sub> dia. 20.8<sup>0</sup><sub>-0.2</sub> T = 0.1 to 0.2 mm</p>

**Attaching and Replacing LED Lamps**

**Removing the LED Lamp from the Panel Surface**

- Insert the LED Lamp Extractor as shown in the following figure and then rotate the Extractor in the direction shown at (2) while pressing it inward.

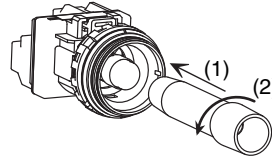

**Attaching the LED Lamp from the Panel Surface**

- Insert the LED Lamp into the LED Lamp Extractor as shown in the following figure. Align the projections on the LED Lamp with the LED Lamp insertion guides, insert the LED Lamp, and turn it in the direction indicated at (2).

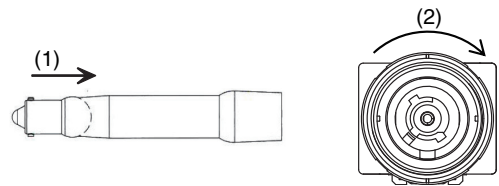



# Terms and Conditions Agreement

## **Read and understand this catalog.**

Please read and understand this catalog before purchasing the products. Please consult your OMRON representative if you have any questions or comments.

## **Warranties.**

(a) Exclusive Warranty. Omron's exclusive warranty is that the Products will be free from defects in materials and workmanship for a period of twelve months from the date of sale by Omron (or such other period expressed in writing by Omron). Omron disclaims all other warranties, express or implied.

(b) Limitations. OMRON MAKES NO WARRANTY OR REPRESENTATION, EXPRESS OR IMPLIED, ABOUT NON-INFRINGEMENT, MERCHANTABILITY OR FITNESS FOR A PARTICULAR PURPOSE OF THE PRODUCTS. BUYER ACKNOWLEDGES THAT IT ALONE HAS DETERMINED THAT THE PRODUCTS WILL SUITABLY MEET THE REQUIREMENTS OF THEIR INTENDED USE.

Omron further disclaims all warranties and responsibility of any type for claims or expenses based on infringement by the Products or otherwise of any intellectual property right. (c) Buyer Remedy. Omron's sole obligation hereunder shall be, at Omron's election, to (i) replace (in the form originally shipped with Buyer responsible for labor charges for removal or replacement thereof) the non-complying Product, (ii) repair the non-complying Product, or (iii) repay or credit Buyer an amount equal to the purchase price of the non-complying Product; provided that in no event shall Omron be responsible for warranty, repair, indemnity or any other claims or expenses regarding the Products unless Omron's analysis confirms that the Products were properly handled, stored, installed and maintained and not subject to contamination, abuse, misuse or inappropriate modification. Return of any Products by Buyer must be approved in writing by Omron before shipment. Omron Companies shall not be liable for the suitability or unsuitability or the results from the use of Products in combination with any electrical or electronic components, circuits, system assemblies or any other materials or substances or environments. Any advice, recommendations or information given orally or in writing, are not to be construed as an amendment or addition to the above warranty.

See <http://www.omron.com/global/> or contact your Omron representative for published information.

## **Limitation on Liability; Etc.**

OMRON COMPANIES SHALL NOT BE LIABLE FOR SPECIAL, INDIRECT, INCIDENTAL, OR CONSEQUENTIAL DAMAGES, LOSS OF PROFITS OR PRODUCTION OR COMMERCIAL LOSS IN ANY WAY CONNECTED WITH THE PRODUCTS, WHETHER SUCH CLAIM IS BASED IN CONTRACT, WARRANTY, NEGLIGENCE OR STRICT LIABILITY.

Further, in no event shall liability of Omron Companies exceed the individual price of the Product on which liability is asserted.

## **Suitability of Use.**

Omron Companies shall not be responsible for conformity with any standards, codes or regulations which apply to the combination of the Product in the Buyer's application or use of the Product. At Buyer's request, Omron will provide applicable third party certification documents identifying ratings and limitations of use which apply to the Product. This information by itself is not sufficient for a complete determination of the suitability of the Product in combination with the end product, machine, system, or other application or use. Buyer shall be solely responsible for determining appropriateness of the particular Product with respect to Buyer's application, product or system. Buyer shall take application responsibility in all cases.

NEVER USE THE PRODUCT FOR AN APPLICATION INVOLVING SERIOUS RISK TO LIFE OR PROPERTY OR IN LARGE QUANTITIES WITHOUT ENSURING THAT THE SYSTEM AS A WHOLE HAS BEEN DESIGNED TO ADDRESS THE RISKS, AND THAT THE OMRON PRODUCT(S) IS PROPERLY RATED AND INSTALLED FOR THE INTENDED USE WITHIN THE OVERALL EQUIPMENT OR SYSTEM.

## **Programmable Products.**

Omron Companies shall not be responsible for the user's programming of a programmable Product, or any consequence thereof.

## **Performance Data.**

Data presented in Omron Company websites, catalogs and other materials is provided as a guide for the user in determining suitability and does not constitute a warranty. It may represent the result of Omron's test conditions, and the user must correlate it to actual application requirements. Actual performance is subject to the Omron's Warranty and Limitations of Liability.

## **Change in Specifications.**

Product specifications and accessories may be changed at any time based on improvements and other reasons. It is our practice to change part numbers when published ratings or features are changed, or when significant construction changes are made. However, some specifications of the Product may be changed without any notice. When in doubt, special part numbers may be assigned to fix or establish key specifications for your application. Please consult with your Omron's representative at any time to confirm actual specifications of purchased Product.

## **Errors and Omissions.**

Information presented by Omron Companies has been checked and is believed to be accurate; however, no responsibility is assumed for clerical, typographical or proofreading errors or omissions.

**OMRON Corporation Industrial Automation Company**

Tokyo, JAPAN

Contact: [www.ia.omron.com](http://www.ia.omron.com)

**Regional Headquarters**

**OMRON EUROPE B.V.**

Wegalaan 67-69, 2132 JD Hoofddorp  
The Netherlands  
Tel: (31)2356-81-300/Fax: (31)2356-81-388

**OMRON ELECTRONICS LLC**

2895 Greenspoint Parkway, Suite 200  
Hoffman Estates, IL 60169 U.S.A  
Tel: (1) 847-843-7900/Fax: (1) 847-843-7787

**OMRON ASIA PACIFIC PTE. LTD.**

No. 438A Alexandra Road # 05-05/08 (Lobby 2),  
Alexandra Technopark,  
Singapore 119967  
Tel: (65) 6835-3011/Fax: (65) 6835-2711

**OMRON (CHINA) CO., LTD.**

Room 2211, Bank of China Tower,  
200 Yin Cheng Zhong Road,  
PuDong New Area, Shanghai, 200120, China  
Tel: (86) 21-5037-2222/Fax: (86) 21-5037-2200

**Authorized Distributor:**

© OMRON Corporation 2015 All Rights Reserved.  
In the interest of product improvement,  
specifications are subject to change without notice.

CSM\_1\_2\_1015

Cat. No. **A242-E1-01**

0415 (0415)